



## C2453/C2653 Installation Instructions 2014-2018 Chevy/GMC 1500 2WD 4.5"/6.5" Suspension Systems

### Read and understand all instructions and warnings prior to installation of product and operation of vehicle.

Zone Offroad Products recommends this system be installed by a professional technician. In addition to these instructions, professional knowledge of disassembly/ reassembly procedures and post installation checks must be known. Minimum tool requirements include the following: Assorted metric and standard wrenches, hammer, hydraulic floor jack and a set of jack stands. See the "Special Tools Required" section for additional tools needed to complete this installation properly and safely.

#### » PRODUCT SAFETY WARNING

Certain Zone Suspension Products are intended to improve off-road performance. Modifying your vehicle for off-road use may result in the vehicle handling differently than a factory equipped vehicle. Extreme care must be used to prevent loss of control or vehicle rollover. Failure to drive your modified vehicle safely may result in serious injury or death. Zone Offroad Products does not recommend the combined use of suspension lifts, body lifts, or other lifting devices.

You should never operate your modified vehicle under the influence of alcohol or drugs. Always drive your modified vehicle at reduced speeds to ensure your ability to control your vehicle under all driving conditions. Always wear your seat belt.

#### » TECHNICAL SUPPORT

[www.zoneoffroad.com](http://www.zoneoffroad.com) may have additional information about this product including the latest instructions, videos, photos, etc.

Send an e-mail to [tech-zone@ridefox.com](mailto:tech-zone@ridefox.com) detailing your issue for a quick response.

**888.998.ZONE** Call to speak directly with Zone tech support.

#### » PRE-INSTALLATION NOTES

1. Special literature required: OE Service Manual for model/year of vehicle. Refer to manual for proper disassembly/reassembly procedures of OE and related components.
2. Adhere to recommendations when replacement fasteners, retainers and keepers are called out in the OE manual.
3. Larger rim and tire combinations may increase leverage on suspension, steering, and related components. When selecting combinations larger than OE, consider the additional stress you could be inducing on the OE and related components.
4. Post suspension system vehicles may experience drive line vibrations. Angles may require tuning, slider on shaft may require replacement, shafts may need to be lengthened or trued, and U-joints may need to be replaced.
5. Secure and properly block vehicle prior to installation of Zone Offroad Products. Always wear safety glasses when using power tools.
6. If installation is to be performed without a hoist, Zone Offroad Products recommends rear alterations first.
7. Due to payload options and initial ride height variances, the amount of lift is a base figure. Final ride height dimensions may vary in accordance to original vehicle attitude. Always measure the attitude prior to beginning installation.

#### Difficulty Level

easy 1 2 **3** 4 5 difficult

Estimated installation: 5-6 hours

#### Special Tools Required

Cut off wheel

#### Tire/Wheel Fitment

##### 6.5" Lift:

35 x 12.50 on 17x9, 18x9 w/ 5" BS

35 x 12.50 on 20x9 w/ 5.75" BS

##### 4.5" Lift:

33 x 12.50 on 17x9, 18x9 w/ 5" BS

33 x 12.50 on 20x9 w/ 5.75" BS

## Kit Contents

### Box Kit ZONC2650- Steel OE Steering Knuckle

### Box Kit ZONC2652 - Aluminum OE Steering Knuckle

Qty	Part
1	Steering Knuckle 02845 - Drv (C2650 only)
1	Steering Knuckle 02846 -Pass (C2650 only)
1	Steering Knuckle - 02847- Drv (C2652 only)
1	Steering Knuckle - 02848 - Pass (C2652 only)
2	Lower Ball Joint Spacer (C2451 only)
1	Front Brake Line Bracket - Drv
1	Front Brake Line Bracket - Pass
1	Rear Brake Line Bracket
2	3" dia x 3" rear bump stop extension
1	Bolt Pack 628 - Rear Bump Stop/Brake Bracket
1	1 5/16" x 1 bolt
1	1 5/16" lock nut
2	2 5/16" SAE washer
2	2 10mm x 110mm Allen head bolt
1	Bolt Pack 621 - Crossmembers
2	2 5/8"-11 x 4-1/2" bolt
2	2 5/8"-11 x 5-1/2" bolt
4	4 5/8"-11 lock nut
8	8 5/8" SAE washer
7	Cable Tie

### Box Kit ZONC2653/C2453

Qty	Part
1	Front Crossmember
1	Rear Crossmember
1	Crossmember Support Strut
1	Bolt Pack 456 - ABS/Skid Plate
4	4 Wire Clip
2	2 1/4"-20 x 3/4" type 23 self tapping bolt
3	3 1/2"-13 x 1-1/4" bolt
7	7 1/2" SAE flat washer
2	2 1/2"-13 x 3" bolt
2	2 1/2"-13 Prevailing torque nut

2	6.5" Lift Strut Spacer (C2653) (Not used with strut replacement kits)
2	4.5" Lift Strut Spacer (C2453) (Not used with strut replacement kits)
1	Bolt Pack 629 - Strut Spacers
6	6 10mm-1.50 lock nut
6	6 3/8" USS washer
2	3" Sway Bar Drop (C2653)
2	1.5" Sway Bar Drop (C2453)
1	Bolt Pack 449 - Sway Bar Drop (C2653)
4	4 10mm-1.50 x 120mm SHCS
4	4 10mm flat washer
1	Bolt Pack 451 - Sway Bar Drop (C2453)
4	4 10mm-1.50 x 80mm SHCS
4	4 10mm flat washer
2	5/8" x 5" Sway Bar Sleeve
8	Sway Bar Bushing
8	Sway Bar Washer
2	3/8" x 9" Sway Bar Bolt
2	3/8" nylock nut
2	5" Lift Block (C2653)
2	4" Lift Block (C2453)
4	9/16" x 2 9/16" x 12-1/2" Square U-Bolt w/nuts & washers (C2653)
4	9/16" x 2-9/16" x 11-3/8" Square U-Bolts w/nuts & washers (C2453)

# INSTALLATION INSTRUCTIONS

## » PRE-INSTALLATION NOTE

1. **\*IMPORTANT\*** Verify whether the truck has steel or aluminum factory steering knuckles. This kit is specific for each type of knuckle due to differences in ball-joint taper. Using the parts list verify you have the correct knuckle box kit for your truck. The knuckles also are marked with the part numbers listed.
2. **\*IMPORTANT\*** GM issued a safety recall (#42190) for some 2016-17 vehicles built before 4/8/16 that were equipped with stamped steel upper control arms due to poor weld quality. Zone Offroad strongly recommends checking if your vehicle is included in the recall and having the fix performed before installing this suspension system.

## » FRONT DISASSEMBLY

1. Park the vehicle on a clean, flat surface and block the rear wheels for safety.
2. Raise the front of the vehicle with a hydraulic jack and support the frame with jack stands. Remove the wheels.
3. Disconnect the ABS line from the connector on the frame **Figure 1**. Remove the ABS line from the retaining clips at the frame, upper control arm and knuckle.
4. Disconnect the brake line bracket from the upper control arm **Figure 1**. Save bolt.



Figure 1

5. Remove the splash guard from the vehicle. **Figure 2**.

### **Important—measure before starting!**

Measure from the center of the wheel up to the bottom edge of the wheel opening

LF \_\_\_\_\_ RF \_\_\_\_\_

LR \_\_\_\_\_ RR \_\_\_\_\_

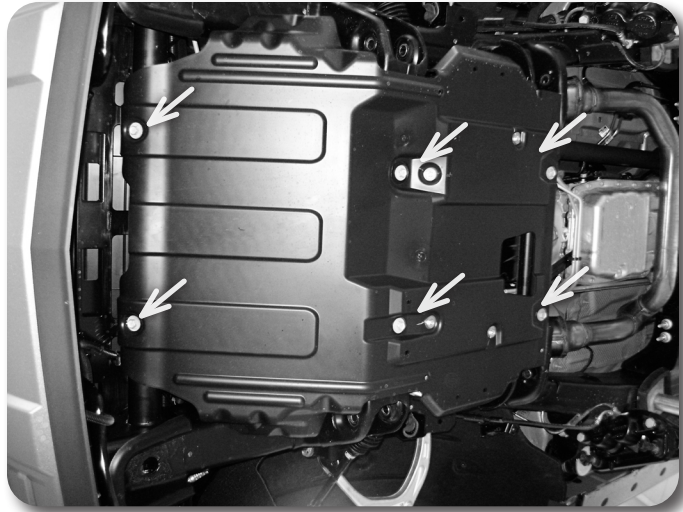

Figure 2

6. Disconnect the steering from the knuckle **Figure 3**. Remove the tie rod end nut. Steel Knuckle: Strike the knuckle near the tie rod end with a hammer to unseat the taper. Aluminum Knuckle: Avoid striking the knuckle, typically the taper unseats more easily and gently hitting the end of the tie rod end will unseat the taper. A pickle fork can also be used. Save the mounting nut.

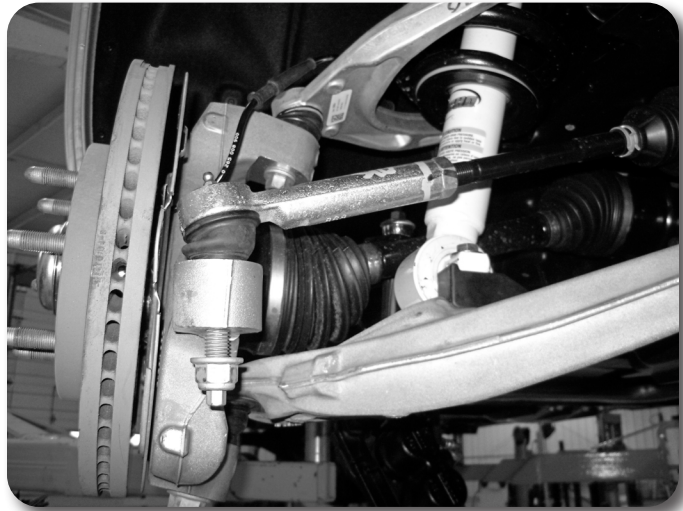

Figure 3

7. Remove the two brake caliper mount bolts and remove the caliper assembly from the knuckle **Figure 4**. Hang the caliper securely out of the way. **DO NOT** hang the caliper by the brake hose. Save caliper bolts.

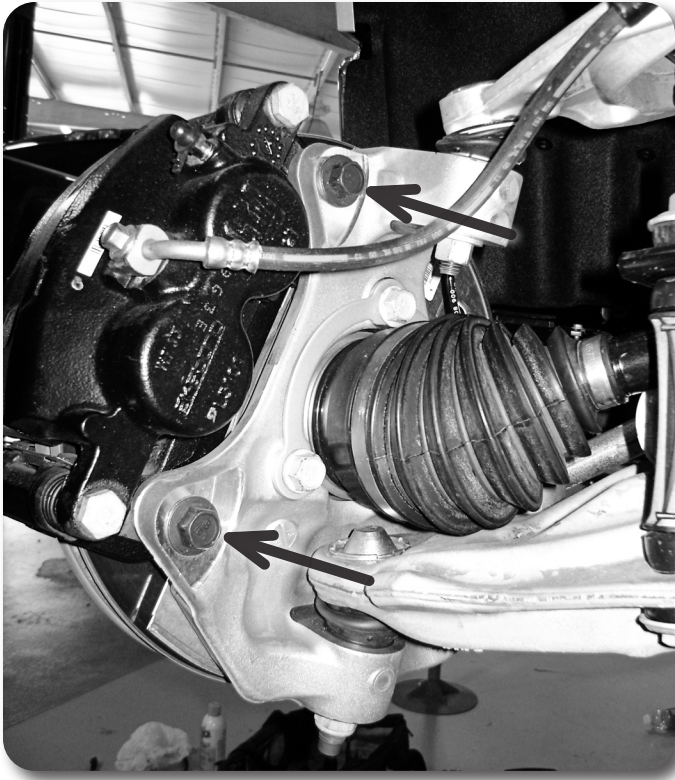

Figure 4

8. Remove the sway bar links from the sway bar and the lower control arm Figure 5.



Figure 5

9. Mark the orientation of the sway bar and remove it from the frame by removing the four bushing cap mounting bolts Figure 6 Save all sway bar components.



Figure 6

10. Mark each of the front strut bodies to indicate driver's versus passenger's side.
11. Support the lower control arm with a jack. Remove the lower strut mount bolts **Figure 7**. Save bolts.



Figure 7

12. Remove the upper and lower ball joint nuts and thread back on by hand a couple of turns. **Steel Knuckle:** Strike the knuckle near the upper and lower ball joints to dislodge the tapered seat. **Aluminum Knuckle:** Avoid striking the knuckle to release the taper, a pickle fork or pry bar can be used to apply a splitting force. Gently hit the end of the ball joint to get it to release. If you do resort to hitting the knuckle avoid anyone trying to re-use them.
13. Remove the upper ball joint nut and lower the lower control arm down. Remove the lower ball joint nut and remove the knuckle assembly from the lower control arm. Save ball joint nuts.
14. Remove the three upper strut mounting nuts **Figure 8** and remove the strut from the vehicle. **DO NOT** remove the center strut rod nut, it is under extreme pressure. Save nuts.

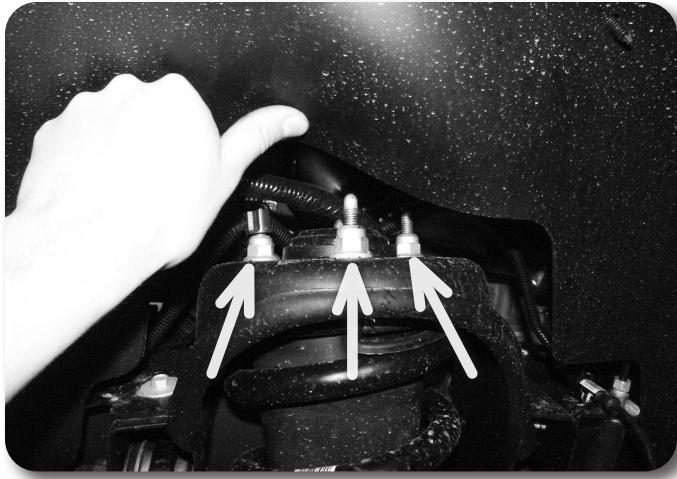

Figure 8

15. Remove the front and rear lower control arm mounting bolts and remove the lower control arm from the vehicle. Save mounting hardware and control arms.
16. Remove the crossmember struts. **Figure 91**

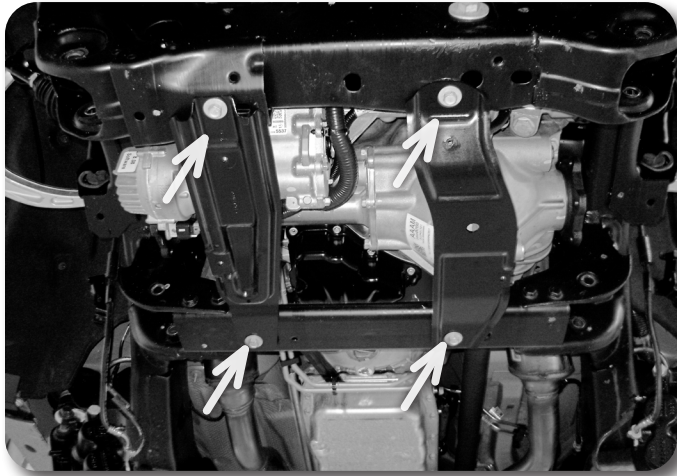

Figure 9

17. Remove the factory rear crossmember from the vehicle by removing the 4 bolts. **Figure 10**. Crossmember and hardware will not be reused.

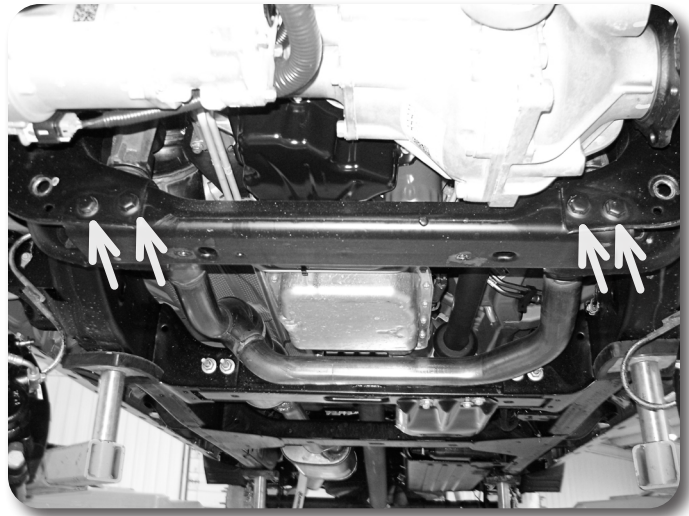

Figure 10

18. Install the new rear crossmember with the factory lower control arm bolts, nuts and washers. The rectangular cross tube should offset closer to the rear of the vehicle. Run the bolts from front to rear. Leave hardware loose.
19. Install the front crossmember in the control arm pockets with the factory lower control arm bolts, nuts and washers. When installed the offset in the crossmember ends should be toward the front of the vehicle **Figure 11**. Run bolts from front to rear. Leave hardware loose.



Figure 11

### Step 20 Note

Hardware for the crossmember support struts is located in hardware pack 643.

20. Attach the provided crossmember support struts to the front and rear crossmembers with 1/2" x 1-1/4" bolts and 1/2" SAE washers in the outer threaded holes in the front crossmember and 1/2" x 3" bolts, nuts and washer through the holes in the rear crossmember. The ends of the support strut are bent to set flush with the bottoms of the crossmembers **Figure 12**. There will be one thread hole left in the center of the front crossmember. Install the remaining 1/2" bolt and washer in this hole. Use Loctite on the bolts. Leave hardware loose.

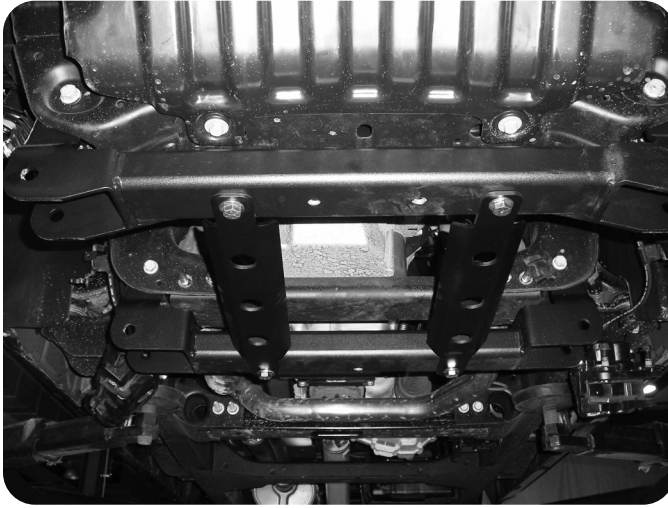

Figure 12

21. Install the OE lower control arms in the new crossmembers and fasten with 5/8" x 4-1/2" (front) and 5/8" x 5-1/2" (rear) bolts, nuts and 5/8" SAE washers. Run the bolts from front to rear. Leave hardware loose.
22. With the crossmembers, control arms, support struts installed, go back and torque the crossmember mounting bolts to 125 ft-lbs and the skid plate/support strut hardware to 65 ft-lbs.

### Step 21 Note

Hardware for the lower control arms is located in bolt pack 621.

## » STRUT SPACER ASSEMBLY

23. Install the provided strut spacers on the struts with provided nuts and washers. The spacers will only install one way. Torque the hardware to 30 ft-lbs. Figure 13

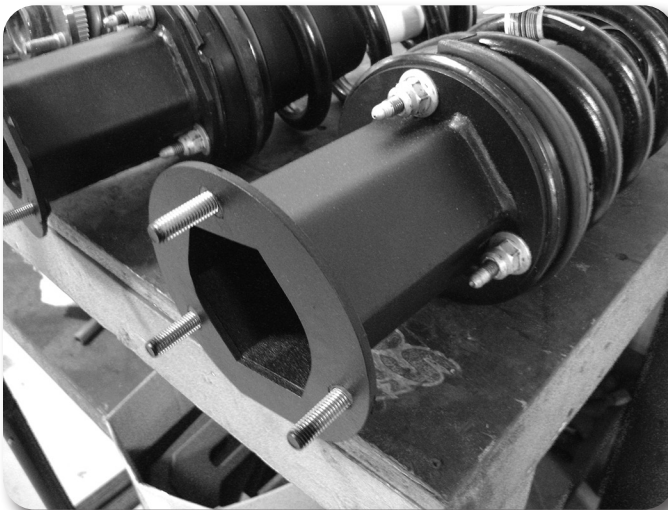

Figure 13A

### Step 23 Note

Hardware for the strut spacers is located in bolt pack 629.

## » REPLACEMENT STRUT ASSEMBLY

24. Place indexing marks on the strut body, strut cap and upper coil seat for reference when the new strut is reassembled. Note the orientation of the bar pin relative to the outside facing upper mounting stud.

### Step 24 Note

If the strut replacement kit is used, the strut spacers are not needed with this kit.

**! Caution** *Coil spring is under extreme pressure. Improper removal/installation of coil spring could result in serious injury or death. Use only a high-quality spring compressor and carefully read and follow the manufacturer's instructions.*

25. Using an appropriate strut compressor, compress the coil spring and remove the upper strut nut. Remove the strut from the coil spring. Release the pressure from the coil spring and save all of the upper parts for re-installation on the new strut.
26. Remove the OE jounce bumper from the strut. Remove the jounce bumper cap and slide the OE retaining ring up the strut rod for removal. If necessary, it's possible to lay the retaining ring across the jaws of a vice and gently tap the end of the strut to get it to slide off.

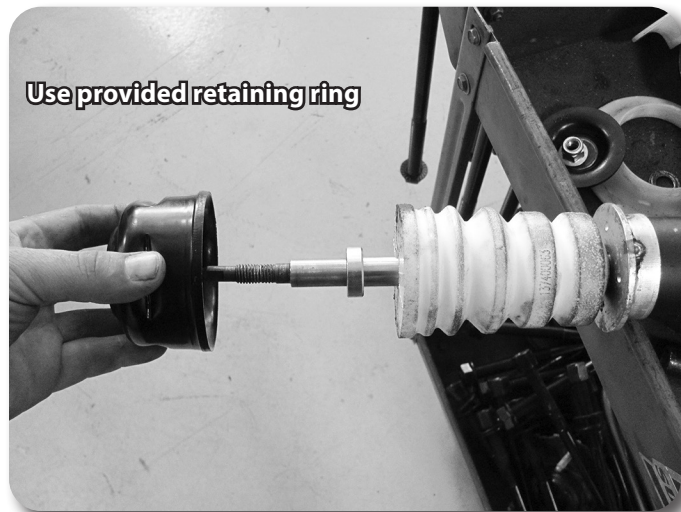

Figure 13B

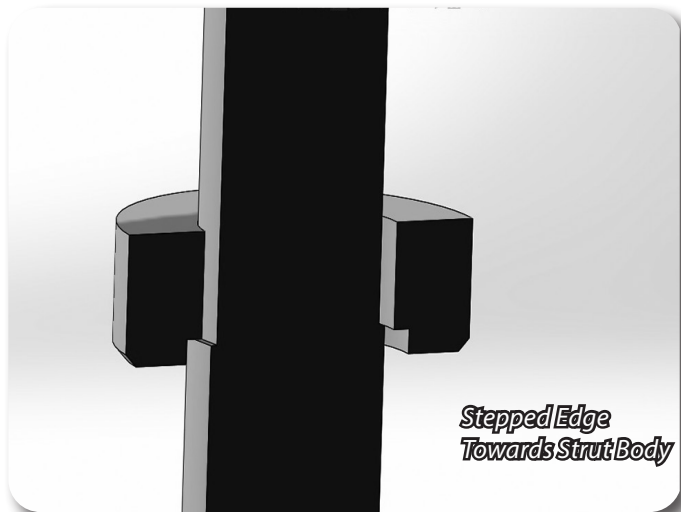

Figure 13C

27. Install the coil spring isolator from the OE strut on the new one. Install the jounce bumper on the new strut followed by the NEW provided retaining ring with the stepped side towards the strut body. Reinstall the jounce bumper cap to the jounce bumper.
28. Re-install the OE strut cap with the OE coil seat and shroud the same as it was installed on the factory strut. The upper strut cap fits best on the OE coil seat in one position. It's easiest to line up your original indexing marks from step 52. Compress the assembly for strut installation.

29. Install the new strut, orienting it the same as the factory one, in the coil spring. Fasten the strut with the NEW provided nut. Pay close attention to the lower mounting bar pin as it is not angled perpendicular to the strut body. This bar pin must be oriented so the bar pin angles down towards the outside of the vehicle once installed. Also verify the coil spring is seated properly on the lower spring seat. **Torque the strut nut to 22 ft-lbs. Do not overtighten the strut stem.**

**! Caution** *Make sure the coil spring is compressed far enough for the nut to tighten against the cap and is not compressing the coil spring. Improper installation can result in strut stem failure.*



Figure 13D

---

## » STRUT / STEERING KNUCKLE INSTALLATION

30. Install the new strut assembly to the appropriate frame mount with the factory flange nuts. Leave hardware loose.
31. Swing the lower control arm up to the strut and fasten it with the original mounting bolts. Torque lower and upper strut hardware to 40 ft-lbs.
32. Remove the hub bearing/rotor assembly and brake dust shield from the factory steering knuckles. Be sure to note which hub goes on which side of the vehicle. Save mounting bolts.
33. The brake dust shield needs to be trimmed. Measure in from the lower vertical edge (opposite the ABS sensor location) 1/2" and make a straight line to the edge shown in Figure 14. Cut the section off of the brake dust shield.

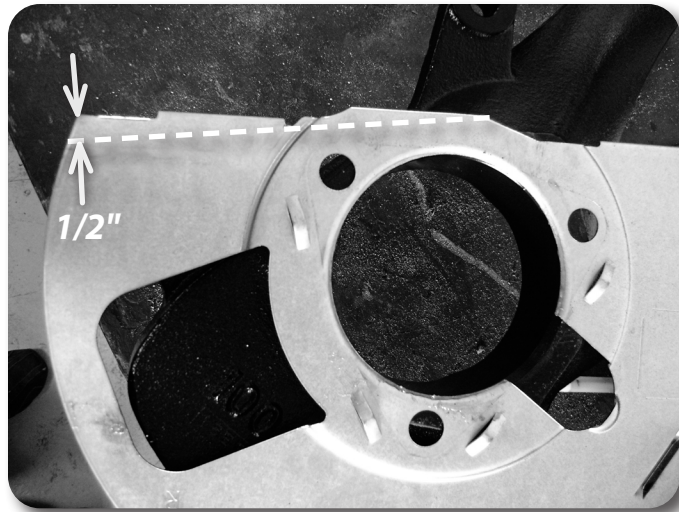

Figure 14

34. Install the modified dust shield and hub/rotor in the corresponding new knuckles. Fasten the hub/shield with the OE bolts. Apply Loctite to the bolt threads and torque to 133 ft-lbs. Be sure that the ABS line is run properly through the dust shield and out above the steering arm on the knuckle.
35. Install the assembled knuckle on the lower control arm. **Steel OE Knuckles:** Use the original lower ball joint nut. **Aluminum OE Knuckles:** Use the provided lower ball joint spacer as shown in Figure 15 with the factory nut. Failure to do so will not allow the lower ball joint to fully seat.



Figure 15 - OE Aluminum Control Arms Only

### Step 36 Note

To make connecting the upper ball joint easier, loosen the upper control arm cam bolts at the frame and rotate the cams to shift the control arm outward. You can also lightly pry down on the arm off of the coil spring.

### Step 39 Note

Leave the nut on the steering link during cutting. This can then be used to clean up the threads if necessary

36. Attach the knuckle to the upper control arm with the original upper ball joint nut.
37. Install the factory CV axle shaft into the hub and fasten with the original nut/washer and torque to 155 ft-lbs. Install dust cap.
38. Torque the upper ball joint nut to 37 ft-lbs and the lower ball joint nut to 74 ft-lbs.
39. Working on one side at a time, remove the tie rod end from the steering link. Trim 5/8" off the tie rod end so the end to center measurement is approx. 4-7/8". **Figure 16.** Trim only 1/2" off of the steering link for maximum thread engagement. **Figure 17** Once the two pieces are trimmed, clean the ends of the threads and reinstall the tie rod end on the steering link so there is about 1/8" of threads showing on the steering link. Repeat on other side of the vehicle.

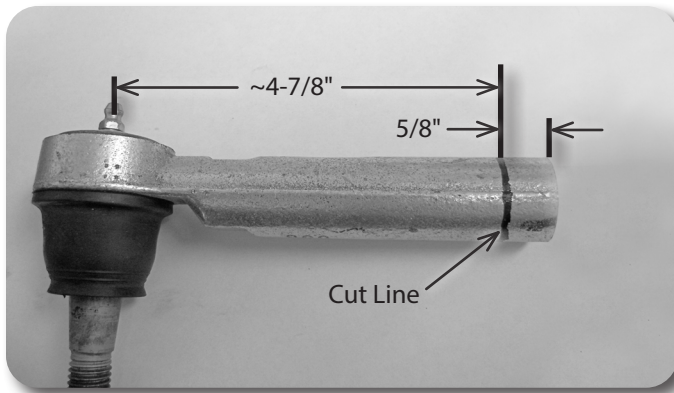

Figure 16

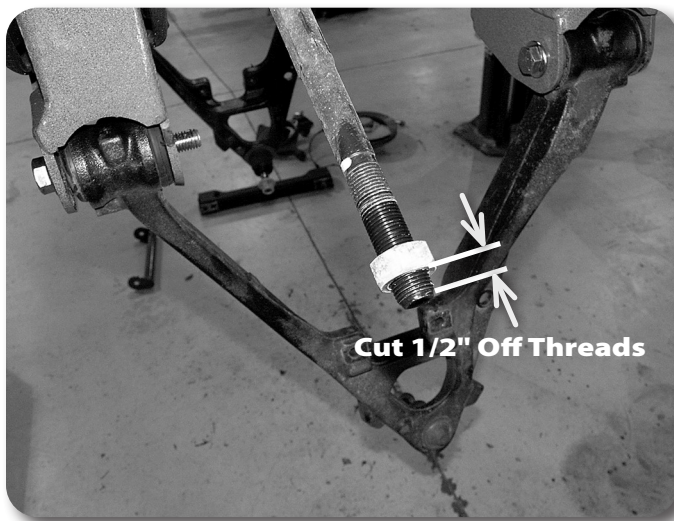

Figure 17

40. Remove the retaining clip and slide the brake line through the bracket. To avoid having to bleed the brakes, cut an opening in the factory brake line bracket so the bracket can be removed from the line. Take care not to cut the brake line. Disconnect the bracket from the frame. Save hardware.
41. Attach the caliper to the new steering knuckle with the original mounting hardware. Torque bolts to 125 ft-lbs.
42. Carefully remove the metal retainer bracket from the factory rubber brake line. This can be done with two vice grips, pliers, or crescent wrenches.
43. Loosely attach the provided brake line bracket to the upper control arm mount using the original mounting bolt. Line up the formed tab in the bracket with the hole in the frame to keep the bracket from rotating.

### Step 40 Note

If you are not comfortable with cutting the bracket, disconnect the rubber line from the hard line. The brake system will have to be bled upon completion.

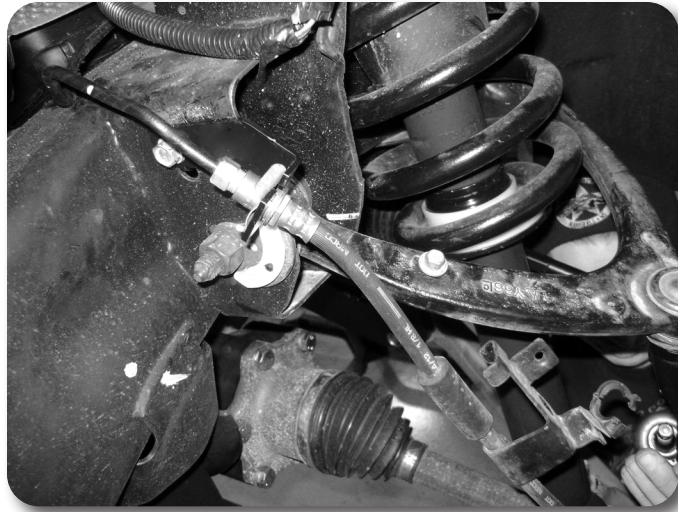

Figure 18

44. Carefully reform the brake hard line down near the new bracket. Run the end of the rubber brake hose through the bracket and attach it to the hard line. Tighten the fitting securely. Retain the brake line to the bracket with the original clip.
45. With the brake line installed go back and torque the new brake line bracket to 20 ft-lbs.
46. Attach the ABS line to the upper control arm with the original brake line mounting bolt and provided wire clamp Figure 19.

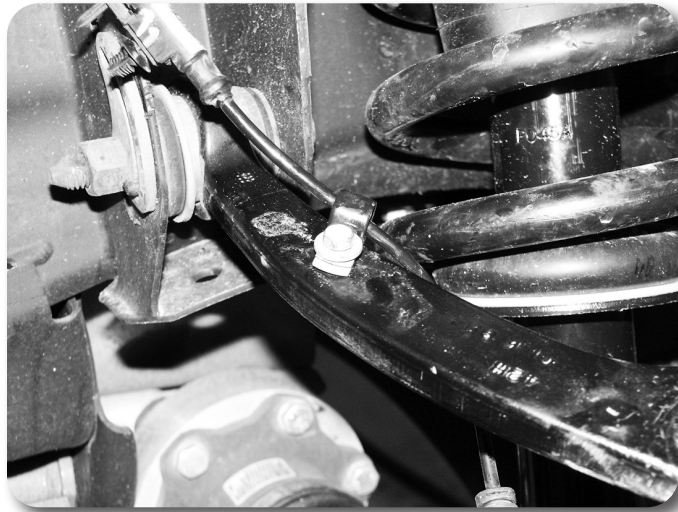

Figure 19

47. Reconnect ABS line at the frame. Attach the ABS line to the steering knuckle with the provided wire clamps and  $\frac{1}{4}$ " x  $\frac{3}{4}$ " self tapping bolt and flat washer. Torque bolt to 15 ft-lbs. Use zip ties to retain the remaining section of the ABS line as needed. Figure 20.

### Step 47 Note

Hardware for the brake line clamps is located in bolt pack 643



Figure 20

48. Attach the front sway bar to the original mounts in the stock orientation in conjunction with the provided drop brackets and 10mm socket head bolts and washers. 6.5" kits use 120mm long bolts, 4.5" kits will use 80mm long bolts. Use Loctite on the bolt threads and torque to 45 ft-lbs **Figure 21**.

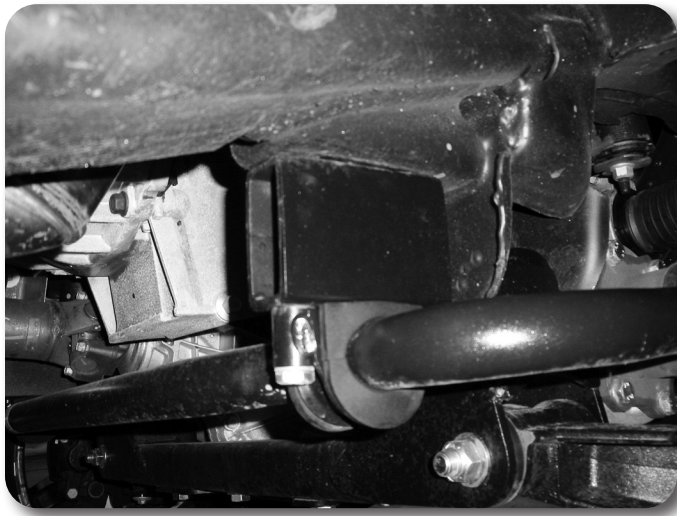

Figure 21

49. The new sway bar links will be built from a 5" sleeve, 3/8" x 9" bolt, bushings and cup washers. Attach these to the sway bar followed by the control arm with the bolt going from the top down. **Figure 22** Tighten the sway bar link until the bushings begin to form to the control arm surface.

### Step 48 Note

Hardware for the sway bar drops is located in bolt pack 449 for 6.5" kits and bolt pack 451 for 4.5" kits



Figure 22

50. Connect the steering tie rod ends to the knuckles with the factory tie rod end nuts. Torque to 60 ft-lbs. Tighten the tie rod end jam nuts securely. They will be adjusted during alignment.
51. Install the wheels/tires and lower the front of the vehicle to the ground. Torque lug nuts to 140 ft-lbs.
52. Bounce the front of the vehicle to settle the suspension. Torque the lower control arm mounting bolts to 150 ft-lbs. If the upper control arm cam bolts were loosened during the installation, center the cams and torque the bolts to 125 ft-lbs.
53. Check all hardware for proper torque.
54. If necessary, bleed the entire brake system. See service manual for proper brake system bleeding procedures.

## » REAR INSTALLATION

1. Block the front wheels. Safely raise the rear of the vehicle and support with jack stands just ahead of the front leaf spring frame mount.
2. Remove the wheels.
3. Support the rear axle with a floor jack.
4. Disconnect the rear brake line bracket from the top of the differential **Figure 23**. Save hardware.

### Step 4 Note

The bracket uses a captive bolt, meaning that it is loosely pressed into the bracket hole.

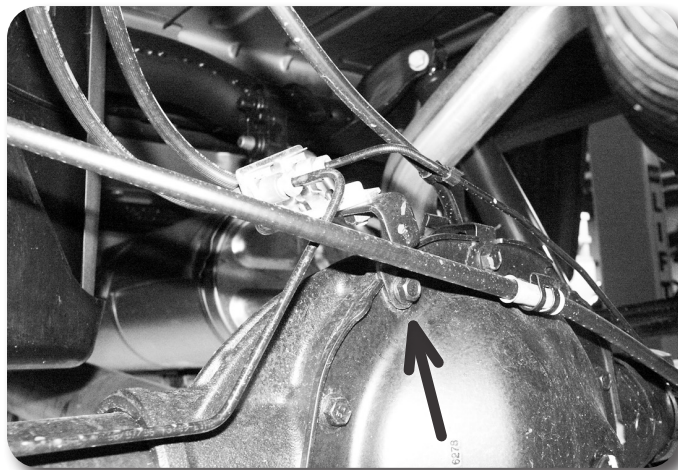

Figure 23

5. Remove the ABS lines from the retaining clip on the bottom of each frame rail. Also disconnect the ABS line connector from the top of the frame rail **Figure 24**.



Figure 24

6. Remove the driver's side parking brake cable brackets from the driver's side frame rail **Figure 25**.



Figure 25

7. Support the center of the axle with a hydraulic jack. Remove the factory shocks from the axle and frame. Save hardware and discard shocks.
8. With the axle still well support remove the passenger's side u-bolts. The u-bolts will not be reused. Slowly lower the axle and remove the factory block from the axle. The factory block will not be reused.

*Note: If installing the optional add-a-leaf kit C6159 with a 6.5" lift, do so now following the instructions included in the kit. This portion of the installation should also be completed one side at time.*

9. Lower the axle just enough to install the new provided lift block between the axle and the spring. Position the block so the male pin side is forward when compared to the female or top of the block. This will assist in shifting the axle forward. Align the pin in the block with the hole in the axle and the hole in the block with the leaf spring pin. It may be necessary to loosen the driver's side u-bolts slightly to allow the axle to lower far enough to install the block. For

### **Step 9 Note**

The hole in the factory axle mount may need to be clearanced slightly for proper pin fitment.

4.5" lifts, the rear block is slightly tapered. The short end of the block mounts toward the front of the vehicle.

- Using the support jack, raise the axle so that the axle, spring and block are all touching. Install the new provided u-bolts, nuts and washers allow with the factory u-bolt plate **Figure 26**. Snug u-bolts but do not tighten.

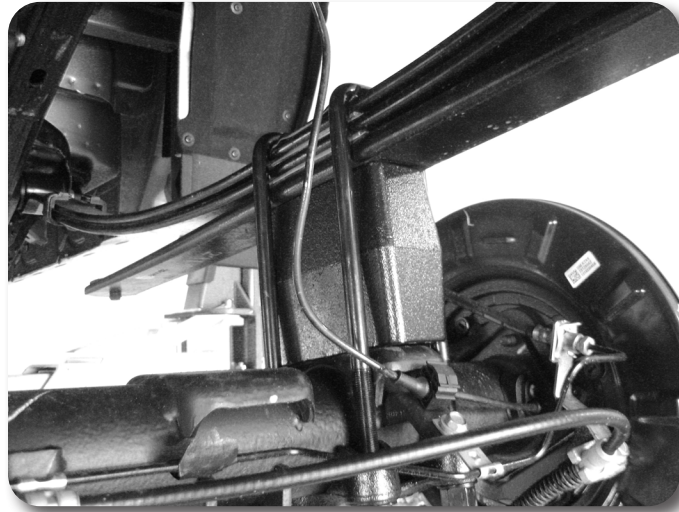

Figure 26

- Repeat the installation on the driver's side of the vehicle. Pay special attention to all of the brake lines and wires. Do not allow them to get over-extended.
- Remove the rear rubber bump stops from the frame. Access the bolt head up through the center of bump stop using a 10mm socket. Remove the bump stop and install the provided 3" diameter x 3" tall spacer between the bump stop and the frame mount with a 10mm x 110mm allen head bolt (Loctite threads). Center the spacer on the lip of the factory bump stop cup and torque bolt to 35 ft-lbs **Figure 27**.

### Step 12 Note

Hardware for the bump stop spacers is located in hardware pack #628.

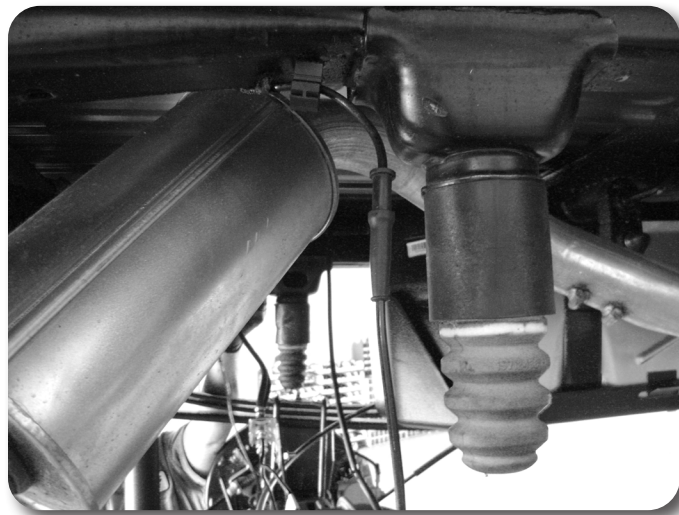

Figure 27

- Locate the new rear shocks. Install the provided bushings and steel sleeves into the eyes of the shocks. Lubricating the bushings and sleeves with some grease will make installation easier.
- Install the new shocks with stock hardware and torque upper and lower bolts to 65 ft-lbs.

15. Install the provided straight 3" brake line bracket to the top of the differential using factory mounting hole and bolt which must be removed from the factory brake line bracket. Attach the factory brake line bracket to the relocation bracket with a 5/16" x 1" bolt, nut and washers. Torque the factory and 5/16" bolt to 20 ft-lbs **Figure 28**.

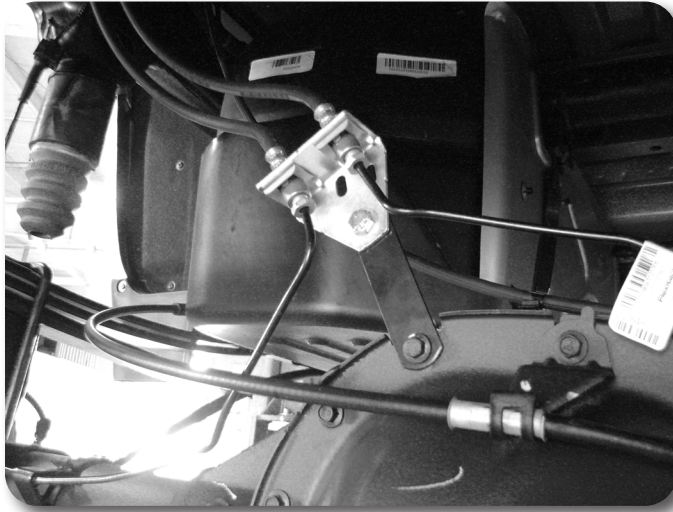

Figure 28

16. Reconnect the ABS lines to the plastic retaining clip at the bottom of each frame rail. The connector will not be reattached to the top of the frame. Reroute the lines as necessary to gain proper slack.
17. Reconnect the parking brake cable brackets to the driver's side frame rail with the original hardware. The driver's side cable will have to be removed from the rear bracket to gain appropriate slack. Torque bolts to 20 ft-lbs.
18. Install wheels and tires. Torque lug nuts to 140 ft-lbs. Lower vehicle.
19. Bounce the rear of the vehicle to settle the suspension. Torque leaf spring u-bolts to 100-120 ft-lbs.

## » POST INSTALLATION

1. Double check all fasteners for proper torque.
2. Check all moving parts for clearance.
3. Complete a full radius turning check to ensure that no interference occurs.
4. Align headlights
5. Double check the brake lines for adequate slack at full wheel travel.
6. Complete a vehicle alignment.
7. Check all fasteners after 500 miles.

### Step 15 Note

Hardware for the brake line bracket is located in hardware pack #628.

### Step 16 Note

Be sure the ABS wire will not contact the exhaust.

### Recommend Alignment Specifications

#### CASTER

$3.30^{\circ} \pm 1.00^{\circ}$

#### CAMBER

$-0.10^{\circ} \pm 0.60^{\circ}$

### Post-Installation Warnings

1. Check all fasteners for proper torque. Check to ensure for adequate clearance between all rotating, mobile, fixed, and heated members. Verify clearance between exhaust and brake lines, fuel lines, fuel tank, floor boards and wiring harness. Check steering gear for clearance. Test and inspect brake system.
2. Perform steering sweep to ensure front brake hoses have adequate slack and do not contact any rotating, mobile or heated members. Inspect rear brake hoses at full extension for adequate slack. Failure to perform hose check/ replacement may result in component failure.
3. Perform head light check and adjustment.
4. Re-torque all fasteners after 500 miles. Always inspect fasteners and components during routine servicing.