

ON PATROL[™]

GEN 3 LED LIGHT BAR INSTALLATION MANUAL

Model 7840-A – 44"

Your purchase of a Wolo warning light bar is the perfect choice to compliment your vehicle. Wolo's warning lights are manufactured with the finest materials. Before being packaged, each light is tested to meet our high standards and ensure a perfect working light. Our quality workmanship and components are Wolo's assurance that this product will provide years of dependable service. If you need help installing or using your new Wolo warning light, our technicians are available to answer your questions, Monday thru Friday, from 9 AM to 4 PM EST at 888-550-4676.

Before installation of the light bar is attempted, it is important to read these instructions completely. The lives of people are dependent on a proper installation of the light bar to the vehicle. The person installing this light bar must have advanced knowledge of the proper method for mounting and securing the light bar to a vehicle's roof or exterior, as well as knowledge of the vehicle's electrical system. Again, read this manual completely and note any messages marked "**IMPORTANT**" or "**WARNING**". A safe installation will prevent serious injury or damage to the vehicle.

ON PATROL comes completely wired and does not require any internal wiring by the installer. The power cable has all the required wires with factory installed terminals and connectors for a successful installation.

Installation of the ON PATROL Light Bar requires drilling into the vehicle. The installer must carefully inspect both sides of the selected locations to ensure that there are no components, wires and/or any other vehicle parts that could be damaged by drilling. **IMPORTANT:** Always de-burr any drilled holes, ensuring that there are no sharp edges. Install a rubber grommet into all metal holes that the wires are being routed through.

Always refer to the vehicle's shop manual for the deployment location of air bags. Never install the light bar's switch control panel, wires and or components in the deployment area of any air bag. Improper installation could reduce the effectiveness of the vehicle's air bag system and/or project an object that could cause serious personal injury or death to the driver and passengers. The user/installer assumes all responsibility to properly access a safe mounting location of the light bar's control panel, which will provide ultimate safety to the driver and passengers inside the vehicle.

The vehicle operator and or maintenance department should inspect the light bar frequently to ensure all brackets are securely attached to the vehicle and that all mounting hardware is free of corrosion.

The light bar's control panel should be mounted in a location where the switches can be easily reached. Never attempt to turn this light bar on/off when driving under hazardous conditions.

These installation instructions should always be kept and stored in a safe location, so that they can be referred to when information, maintenance or reinstallation is required.

Failure to follow all safety precautions and installation procedures outlined in these instructions could result in property damage to the vehicle, serious injury or death to you or others.

MOUNTING LIGHT BAR

1. Place the light bar on the selected location of the vehicle's roof. A preferred mounting position on the roof is close to the B-pillar, which is the strongest part of the roof. **IMPORTANT:** Make sure the light bar is facing the correct direction. **NOTE:** There is a label on the light's front lens indicating the correct direction to mount the light bar.
2. Make sure the selected location of the light bar will allow the stainless steel straps to attach to the vehicle window ledge on both the driver's and passenger sides. See fig 1.

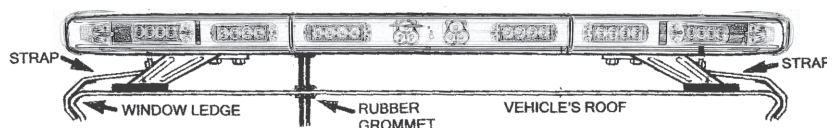

Fig. 1

3. A 1/2" hole will need to be drilled in the roof to route both cables into the interior of the vehicle. Mark the desired hole location; remove the light bar from the roof and drill the hole. The installer must lower the headliner to carefully inspect the selected location to ensure that there are no components, wires and or any other vehicle part that could be damaged before drilling. **WARNING:** The roof has support members that span across from the driver's and passenger side of the vehicle. NEVER drill into a support member! It will be necessary to relocate the cable's access hole, not to come into contact with a support member.
4. **IMPORTANT:** Protect the vehicle's interior headliner from damage that could be caused when drilling the access hole for the light bar's power cable. Always allow a minimum distance of 6" to 8" between the roof and headliner by lowering the headliner before drilling the access hole.
5. **IMPORTANT:** Always de-burr the access hole by using a round file to ensure there are no sharp edges.

6. Supplied with the light bar is a rubber grommet; insert the grommet into the access hole. See fig. 2.



Fig. 2

7. Position the light bar back onto the roof of the vehicle. There are two adjustable brackets located on the bottom of the light bar. The installer will need to adjust the location of the two brackets, each having two-(2) rubber pads, to be close to the edge of the roof. **IMPORTANT:** Always make sure that each of the protective rubber pads are in full contact with the roof. To adjust each bracket, loosen the four 10mm bolts, slide the bracket into position, and tighten the bolts securely. Repeat the same procedure for the bracket on the other end of the light bar. See fig. 3.

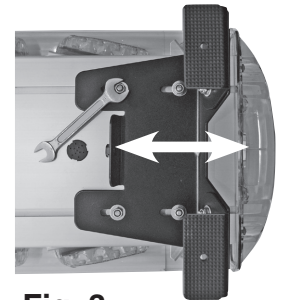

Fig. 3

ADJUST HEIGHT OF LIGHT BAR

8. ON PATROL is a low profile light bar with a feature that allows the installer to adjust the height and clearance between the bottom of the light and the vehicle's roof. There are two screws directly above each of the rubber pads. Using a 4mm Allen wrench, loosen the four (4) screws on one side of the light bar. Adjust the height and tighten screws. Repeat process on opposite side. See fig. 4.



Fig. 4

INSTALLATION OF STAINLESS STEEL STRAPS

9. Open the vehicle's door to determine the location where the stainless steel straps will clamp to the windows ledge. You may need to move the rubber weather-strip away from the vehicle. Only remove enough weather-strip so that the area where the stainless steel strap will be secured to the vehicle is exposed. Repeat the procedure for other side of vehicle.

10. Place one of the stainless steel strap's into position on the window ledge and insert the tension adjustment bolt through the strap's "L" bracket. Thread bolt into the light bar's bracket, hand tighten. **IMPORTANT:** The

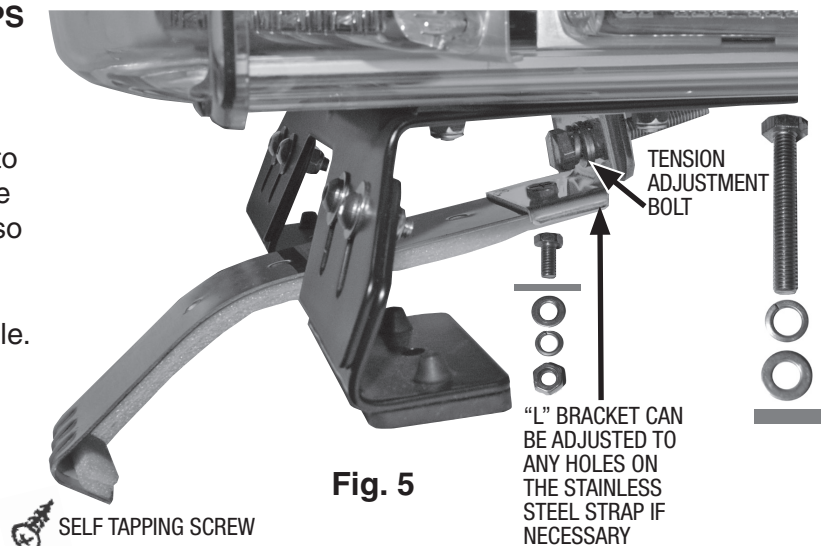

Fig. 5

"L" bracket can be repositioned for proper installation by simply removing the screw securing it to the stainless steel strap. Reposition and secure the "L" bracket in preferred location using the screw and nut removed earlier. Repeat the procedure for other side of vehicle. **WARNING:** The two-(2) stainless steel straps included with the light bar are universal and should securely hold onto the window ledge of most vehicles. Some vehicles may require a custom designed strap for that vehicle's body. Always make sure that both straps have a full hold on the vehicles window ledge. **IMPORTANT:** Supplied straps can be bent to contour of the roof.

11. Tighten the two-(2) tension adjustment bolts evenly. While tightening the bolts make sure the light bar remains in the desired mounting position on the roof. Torque bolts to 10-12 ft-lbs. Failure to properly tighten the tension adjustment bolts and straps could result in damage to the vehicle and/or injury to driver or others.
12. The hook of the stainless steel strap that is secured to the vehicle's window ledge has a hole located in the middle. Using the hole in the hook as a template and drill a 5/32" hole. Secure the hook to the vehicle using the self-tapping screw provided. **IMPORTANT:** The installer may have to lower the headliner and inspect the selected location to ensure that there are no components, wires and or any other vehicle part that could be damaged by drilling. See Fig. 5.
13. Place the vehicle's weather-stripping back into position.

ALTERNATE MOUNTING METHOD

14. The light bar can be mounted directly to the vehicle's body by the following method: Each of the four rubber covered bracket legs has a hole in the center. Use the hole as a template, mark the location and drill a 1/4" hole. **IMPORTANT:** The installer may have to lower headliner and inspect the selected location to ensure that there are no components, wires and or any other vehicle part that could be damaged by drilling.
15. Mounting hardware is not provided for the alternate mounting method. It is recommend that only stainless steel hardware be used. Additionally, a large diameter flat washer must be used, positioning the flat washer onto the screw so that it is in direct contact with the inside surface of the roof followed by a split lock washer and nut.
16. Insert the light bars two cables into the roof's access hole that was drilled earlier. Make sure the rubber grommet was placed into the access hole. Route the power cable into the B-pillar.
17. The two cables will make an approximate 90° bend into the B-pillar. Depending on the vehicle, this can sometimes be difficult, but it is the recommended procedure for proper installation. Installation will vary for each make and model vehicle and it is up to the installation technician's discretion whether to route the power cable as recommend through the B-pillar or use an alternative routing method. Route the two cables down to the bottom of the B-pillar and the pull the full length of each cable into the interior of the vehicle. See Fig. 6.
18. Make sure the power cable has been completely pulled into the vehicle, use silicon or similar waterproof material around the grommet and power cable to ensure a waterproof installation.

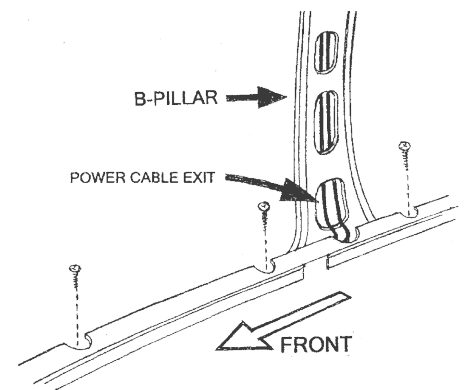

Fig. 6

MOUNTING & WIRING SWITCH CONTROL PANEL

Always refer to the vehicle's shop manual for the deployment location of air bags. Never install the light bar's switch control panel, wires and or components in the deployment area of any air bag. Improper installation could reduce the effectiveness of the vehicle's air bag system and/or project an object that could cause serious personal injury or death to the driver and passengers. The user/installer assumes all responsibility to properly access a safe mounting location of the light bar's control panel, which will provide ultimate safety to the driver and passengers inside the vehicle.

19. The light bar's switch control panel needs to be mounted in a location that can easily be reached. **Note:** there are two methods to mount the switch controller, either by using the double face tape provided or the plastic mounting bracket, which is secured to the mounting surface with screws. **IMPORTANT:** The installer must inspect the selected location to ensure that there are no components, wires and or any other vehicle part that could be damaged by drilling.

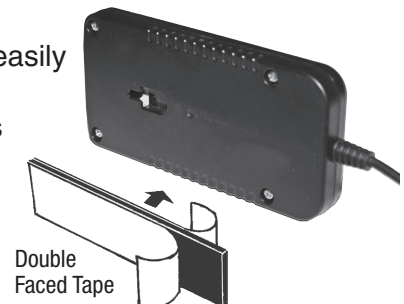

Fig. 7

- 20A. **TAPE METHOD:** Remove the switch controller from the mounting bracket. Make sure the vehicle's mounting surface and the back of the switch controller are clean and free of dust, dirt, oil, wax and etc. Using the double face tape provided, secure to the back of the switch controller and then mount to the selected location. See Fig. 7.

20B. **SCREW METHOD:** Using the mounting bracket as a template, mark the two screw hole locations and drill to size. 3/32". Secure the mounting bracket using the screws provided. See fig. 8.

21. You will need to drill an 11/64" hole directly under the mounting bracket. The wires that will connect to the switch controller will be routed through the hole. **IMPORTANT:** Always de-burr the wire access hole using a round file to ensure there are no sharp edges.

22. Route the cable that has the four-(4) colored wires to the switch controller

23. Insert the four-(4) different colored wires into the white plastic plug as indicated. The plug has a label showing the correct position for each colored wire. **IMPORTANT:** Each of the four- (4) colored wires has a round bayonet terminal that will permanently lock into the plug. **NOTE:** Before inserting the wire into the white plastic plug, make sure it is in the correct position. When the wire and terminal are inserted into the plug, they are not removable. See fig. 9.



Fig. 9

24. Connect the switch control panel's male plug to the power cable's female plug.

WIRING POWER CABLE See fig 10 Cable that has two wires (red and black)

25. **WARNING:** Failure to wire the light bar correctly could result in permanent damage to the light bar, the vehicle's electrical system and/or cause a fire. If any switch, fuse or wire is replaced, they must meet or exceed specifications rating specified in this manual. Any deviation to the electrical specifications is at the installers/users risk. **IMPORTANT:**

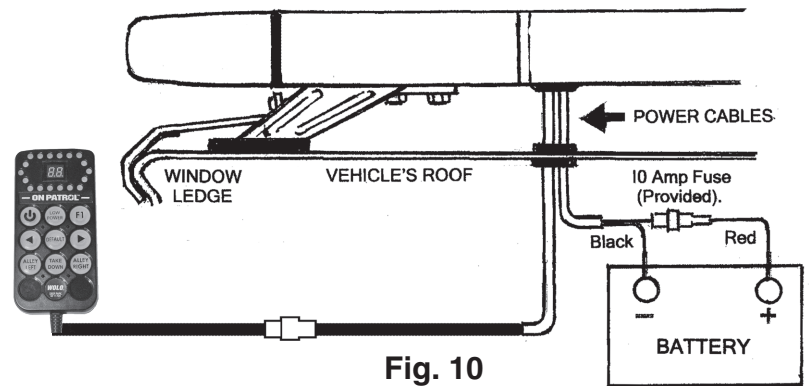

Fig. 10

Disconnect the vehicle's battery before beginning any wiring. **IMPORTANT:** The RED wire must be connected to the 10 amp inline fuse (included with light bar) at the 12-volt power source, such as: the fuse block, the vehicle's battery, or any 12-volt power source which is rated by vehicle's manufacturer capable of handling 10 amps. The fuse should never be more than ten (10) inches from the power source. If either the red or black wires need to be lengthened, use 18 gauge or heavier wire. The light bar is a low current device, to operate this product at peak performance, make sure all connections are clean of paint, rust and corrosion and firmly secured.

26. **RED & BLACK WIRES:** ROUTE the wires to the vehicles fuse block, accessory source or battery. If the power wires pass through the firewall or any drilled hole, always de-burr the hole with a round file and use a rubber grommet to protect the cable and internal wires.

27. **BLACK WIRE:** Connect to ground by securing the wire under any metal body bolt or the negative (-) battery post. Make sure that the METAL surface around the bolt that secures the wire is clean of rust, oxidation and paint to ensure a good electrical connection.



28. **RED WIRE:** Connect to positive (+) 12-volts such as the fuse block, accessory power source or the positive (+) battery post. Always use the inline fuse provided. **IMPORTANT:** The 10 amp inline fuse should never be more than ten (10) inches from the power source. Make sure the connection is at a location that is clean, free of corrosion or oxidation.



Fig. 8

29. To prevent shorts, make sure all wire connections are properly insulated.
30. Make sure all wires are securely fastened to the vehicle using plastic wire ties or electrical tape (not provided). **WARNING:** Carefully inspect the interior driver's area to make sure the light bar wires or the vehicle's electrical system wires are not interfering with the operation of vehicle's controls; accelerator, brake, clutch pedals and etc.

OPERATING LIGHT BAR

31.  The top row left button on the switch controller is the light bar's power on/off. When the light bar's power is turned on, all of the push buttons on the face of the switch controller will illuminate. The light bar will flash in the same light pattern that was last used before shut down.
- 31A. **LOW POWER:** The top row center button controls two levels of brightness for the warning lights, either full or 30%. Press the LOW POWER button once to change brightness.
- 31B. **F1:** The top row right button allows the user to memorize one favorite light pattern. To program: select the light pattern to be your favorite (Note the pattern numerical display for pattern number), press and hold the **F1** button for three (3) seconds, programming is complete. Stored light pattern can be recalled instantly by pressing F1 momentarily. Repeat the above procedure any time the user wants to change the light pattern controlled by the **F1** button.
- 31C.  The middle row left button controls the light pattern. Press to change to the next declining pattern in the 20 pattern series. (Ex. Switch from pattern 10 to pattern 9). The controllers flash pattern indicators will display the pattern in use for a period of five seconds. The numerical display will remain illuminated to the selected pattern number.
- 31D. **DEFAULT:** The middle row center button when pressed will default to pattern 01. The controllers flash pattern indicators will display the 01 pattern for a period of five seconds. The numerical display will illuminate 01.
- 31E.  The middle row right button controls the light pattern. Press to change to the next increasing pattern in the 20 pattern series. (Ex. Switch from pattern 9 to pattern 10). The controllers flash pattern indicators will display the pattern in use for a period of five seconds. The numerical display will remain illuminated to the selected pattern number.
- 31F. **ALLEY LEFT:** The bottom row left button controls the left alley light. When the button is pressed the driver side alley light will illuminate. The controller's left alley light indicator will illuminate for a period of five seconds. Press button again to turn off the light.
- 31G. **TAKE DOWN:** The bottom row center button controls the take down lights. When the button is pressed the front two alley lights will illuminate. The controller's front alley light indicator will illuminate for a period of five seconds. Press button again to turn off lights.
- 31H. **ALLEY RIGHT:** The bottom row right button controls the right alley light. When the button is pressed the passenger side alley light will illuminate. The controller's right alley light indicator will illuminate for a period of five seconds. Press button again to turn off the light.

CLEANING

A scratched, dull or dirty lens will cause a reduction in brightness of warning light. Never use a caustic or petroleum based cleaner on any surface of the warning light. For best cleaning results, always use household glass cleaner or mild soap with a soft lint free rag. If the lens has scratches, or is dull, it is recommended those components be replaced to ensure maximum brightness of the warning light.

PATTERN	DESCRIPTION
1	120 FPM DOUBLE FLASH (SIM)
2	120 FPM DOUBLE FLASH ALERT (DIAGONAL ALT)
3	120 FPM DOUBLE FLASH ALERT
4	120 FPM DOUBLE FLASH ALERT (RIGHT-LEFT ALT)
5	120 FPM QUAD FLASH ALERT (SIM)
6	120 FPM QUAD FLASH ALERT (DIAGONAL ALT)
7	120 FPM QUAD FLASH ALERT
8	120 FPM QUAD FLASH ALERT (RIGHT-LEFT ALT)
9	75 FPM SINGLE FLASH ALERT (SIM)
10	75 FPM SINGLE FLASH ALERT (DIAGONAL ALT)
11	75 FPM SINGLE FLASH ALERT
12	75 FPM SINGLE FLASH ALERT (RIGHT-LEFT ALT)
13	75 FPM QUAD FLASH ALERT (SIM)
14	75 FPM QUAD FLASH ALERT (DIAGONAL ALT)
15	75 FPM QUAD FLASH ALERT
16	75 FPM QUAD FLASH ALERT (RIGHT-LEFT ALT)
17	RIGHT-LEFT FLASH ALERT
18	PING PONG FLASH ALERT
19	ROTATING FLASH ALERT (RIGHT-LEFT)
20	ROTATING FLASH ALERT (RIGHT-LEFT)

SIM-At the same time

Operating voltage: 11-14 VDC

Peak current with Alley and Take Down lights on: 6 amps

Low power mode: Decrease normal mode by 70%

WARRANTY

Wolo Manufacturing Corporation (“Wolo”) warranties to the original purchaser, for twelve months from the date of purchase, that this product is free from defects in workmanship and materials. If there is such a proven defect, Wolo, at its option, will either repair or replace the item free of charge, if it is returned to Wolo within twelve months from the date of purchase together with proof of purchase as described below. Wolo reserves the right to inspect any defect prior to settling any warranty claim by repair or replacement. This warranty is limited as above provided and Wolo will not be responsible for fire or other casualty or accident, due to neglect, abuse, abnormal use, modifications, faulty installation of this product, or natural causes.

ANY EXPRESSED WARRANTY NOT PROVIDED HEREIN IS EXCLUDED AND DISCLAIMED. THE IMPLIED WARRANTIES OF MERCHANTABILITY AND OF FITNESS FOR A PARTICULAR PURPOSE ARE EXPRESSLY LIMITED TO A TERM OF TWELVE (12) MONTHS. UNDER NO CIRCUMSTANCES SHALL WOLO BE LIABLE TO PURCHASER OR ANY OTHER PERSON FOR ANY SPECIAL OR CONSEQUENTIAL DAMAGES, WHETHER ARISING OUT OF BREACH OF WARRANTY OR OTHERWISE.

To obtain warranty service, return the product prepaid, and include the original bill of sale showing the date of purchase. Provide with the return a brief description of the problem with a daytime telephone number. Also, include with the return a check or money order in the amount of \$20.00 to cover return shipping.

Return to:

Wolo Manufacturing Corp.
 Attn: Warranty Service
 One Saxwood Street, Deer Park, NY 11729
 E-mail: tech@wolo-mfg.com