



34935 Flyover Ct. Bakersfield, CA 93308
Phone: (661) 588-8085 | Fax: (661) 588-8295

INSTALL INSTRUCTIONS:
COGNITO Caster Adjustable
Radius Arm Kit
SKU: 120-90408

PARTS LIST FOR SKU: 120-90408

QTY.	PART #	DESCRIPTION
1	8522	FSD Radius Arm Driver
1	8523	FSD Radius Arm Passenger
1	8524	Radius Arm Clevis and Rod End Passenger
1	8525	Radius Arm Clevis and Rod End Driver
1	HP9164	FSD Radius Arm Pivot Bushing Kit
2	HP9202	FSD Radius Arm Hardware



HP9164 – FSD Radius Arm Pivot Bushing Kit

QTY.	PART #	DESCRIPTION
2	5617	Ford Radius Arm, Crush Sleeve
4	POLY-BUSHING-2509.1	Black Polyurethane Spring Bushing
1	-	M18x2.5 Lock Nut
1	-	7/16" SAE Flat Washer

WARNING

Please read this entire instruction sheet before beginning installation. Proper installation of these components requires a qualified mechanic. Always wear safety glasses when using power tools, and take appropriate precautions when working under a vehicle. If these instructions are not properly followed you may jeopardize your, and your passenger's safety, and severe frame, suspension or tire damage may also result from improper installation.

HP9202 – FSD Radius Arm Hardware

QTY.	PART #	DESCRIPTION
4	6198	FSD Radius Arm Misalignment Spacer
4	H-15267	9/16"-12 x 3.50 Lg. Cap Screw
4	H-33088	9/16" SAE Flat Washer
2	H-37270	9/16"-12 Lock Nut

INTRODUCTION

Cognito caster adjustable radius arms are an off-road styled, boxed sheet metal design that is a direct replacement for OEM radius arms. The modified axle mounting geometry provides an adjustable caster range thus resulting in excellent ground clearance over OEM arms with drop brackets. This radius arm kit can also be used with Cognito 6" and 8" lifts with a short radius arm drop bracket that provides excellent ground clearance for proper off-road use and style. Caster adjustment is necessary when adding larger tires that warrant caster angle and cross caster adjustments for proper street drivability. The solution from Cognito is a fine adjustment that is easy to make on the truck without having to disassemble any components. The adjustment is on the lower axle mount rather than the upper to prevent the front axle and tires from being pulled rearward during adjustment, which can cause large tires to rub the fender wells or front of the cab.

REQUIREMENTS

- Installation requires a qualified mechanic
- A lift is required to perform the installation of these products and always ensure the vehicle is properly supported before attempting installation or serious injury may occur.
- Read instructions carefully and study the pictures before attempting installation.

TECHNICAL INFORMATION

- Check the parts and hardware packages against the parts list to assure that your kit is complete
- Each lift kit, and options to lift kits, are packaged separately. Therefore installation procedures are covered in separate instructions. Familiarize yourself with each specific set of instructions before beginning.
- Follow the OE specifications when replacing or re-installing OE fasteners, retainers, and hardware specified in the OEM manual

INSTALLATION

Figure 1: Radius Arm and Bushing Components



1. Locate the following parts (Figure 1).
 - (1) – Super Duty Radius Arm Driver (Part # 8522)
 - (1) – Super Duty Radius Arm Passenger (Part # 8523)
 - (4) – Poly Bushing (Part # POLY-BUSHING-2509.1)
 - (2) – Pivot Crush Sleeve (Part # 5617)

Figure 2: Install Radius Arm Bushings



Figure 3: Grease Bushings



2. Install (2) poly bushings per radius arm from each side (Figure 2). A light lubricant, WD-40, may be used to install but do not grease the outside of the bushing. Once the bushings are installed in radius arms, then grease the inside bore of each bushing (Figure 3).

Figure 4: Install Radius Arm Crush Sleeves



Figure 5: Radius Arm Pivot Assembly



3. Install the crush sleeve by using a press or rubber mallet (Figure 4). Once installed, the crush sleeve should be flush with the bushing faces on both sides of the radius arm (Figure 5).

Figure 6: Radius Arm Clevis and Hardware



4. Locate the following components.

- (1) - Radius Arm Clevis and Rod End Passenger (Part # 8525)
- (2) – FSD Radius Arm Misalignment Spacer (Part # 6198)
- (1) - 9/16"-12 x 3.50 Lg. Cap Screw
- (2) - 9/16" SAE Flat Washer
- (1) - 9/16" Lock Nut

Figure 7: Install Spacers



Figure 8: Attach clevis.

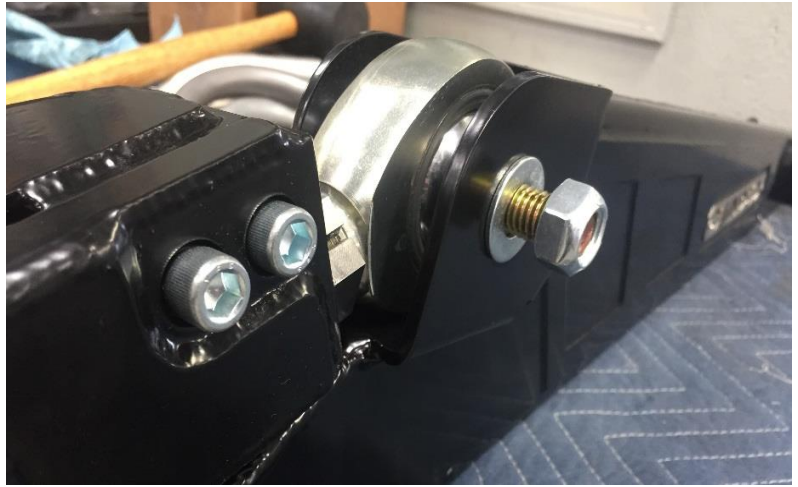

5. Insert the spacers into the rod end from each side as shown (Figure 7). Install the rod end into the radius arm pivot pocket and assemble using the supplied hardware. The cap screw should be inserted from the outside of the vehicle towards the center with one washer per side of the pivot pocket as shown (Figure 8). Do not tighten at this time.

Figure 9: Radius Arm Bolt Locations



6. Before starting step 5, chock the tires and raise the vehicle or support front axle housing at a position so the front tires are just touching the ground (Figure 9). Remove the passenger side OE radius arm by removing the three M18 bolts (A, B, C).

Figure 10: Front Radius Arm Mounting

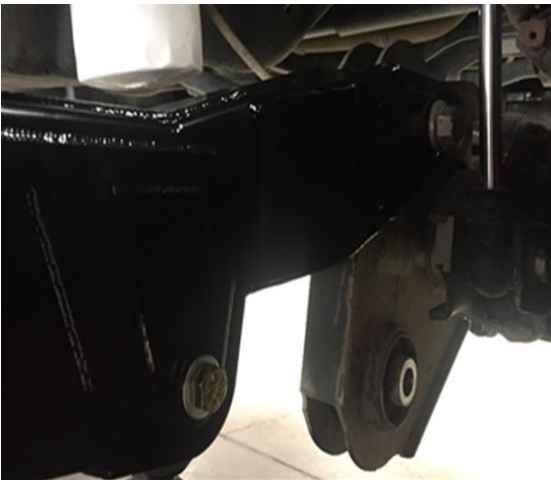

Figure 11: Mount position "B"



7. Install the Cognito radius arm by inserting the upper front axle mount into radius arm front pivot pocket (Figure 10). Assemble using the OE M18 bolt previously removed, but do not tighten at this time.

8. If installing a Cognito 4" Drop Down Bracket Kit (Part # 120-70088), refer to Install Sheet, 7167 before proceeding. Install the rear of the radius arm by inserting the bushings into the frame or drop bracket pivot pocket (Figure 11). Assemble using the OE M18 bolt previously removed, but do not tighten at this time.

Figure 12: Radius Arm Clevis Adjusting



Figure 13: Rod End MAX. Distance

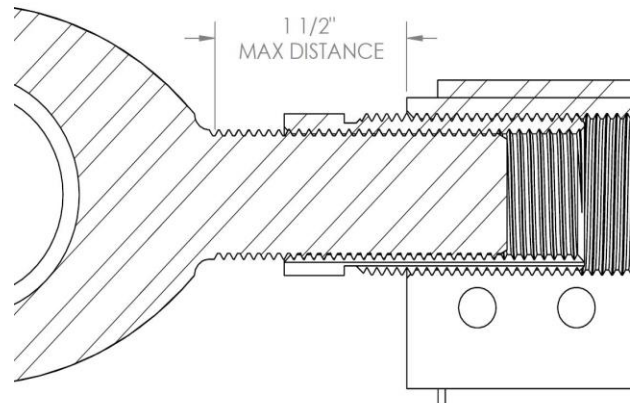

9. Prior to mounting the radius arm clevis, make sure the rod end and adjuster sleeve are threaded all the way into the clevis (Figure 12). Adjust the radius arm clevis length by rotating the adjuster nut until the clevis is aligned with the lower front axle mount (Figure 12). When adjusting, make sure the distance between end of radius arm and rod end does not exceed 1 1/2 in. (Figure 13).

Figure 14: Clevis Installed



Figure 15: Adjuster Clamp Screws



10. Assemble using the OE M18 bolt previously removed, and tighten all three OE M18 bolts to the OE torque specification (Figure 14). Clamp the adjuster nut by tightening both 3/8-16 socket head cap screws to 35 ft.-lbs. and (1) 9/16-12" x 3.50 Lg. cap screw to 135 ft.-lbs. (Figure 15).

11. Repeat steps (4 – 10) for the installation of the driver side components listed below:

- (1) - Super Duty Radius Arm Driver (Part # 8522)
- (1) - Radius Arm Clevis and Rod End Passenger (Part # 8525)
- (2) - FSD Radius Arm Spacer (Part # 6198)
- (1) - 9/16"-12 x 3-1/2" Lg. Cap Screw
- (2) - 9/16" SAE Flat Washer
- (1) - 9/16"-12 Lock Nut

WARRANTY / RETURN POLICY / SAFETY

Cognito Limited Lifetime Warranty

Cognito Motorsports, Inc. hereinafter “Cognito,” warrants to the original retail purchaser, that its suspension products are free from workmanship and material defects for as long as the purchaser owns the vehicle on which the product(s) were originally installed. This warranty will be void if any modifications are made to the components, including alterations to the surface finish, i.e.; painting, powder coating, plating, and/or welding, or if they are improperly installed. Cognito truck suspension products are not designed nor intended to be installed on “competition” vehicles used in race applications, stunt or for exhibition purposes that are outside of the intended operating conditions specified by the manufacturer. Racing and competition are defined as any contests between two or more vehicles; or vehicles competing individually on off road circuits in timed events (whether or not such contests are for an award or prize).

This warranty does not include coverage for police, taxi, government or commercial vehicles, and the warranty does not cover Cognito products sold outside of the USA. Cognito’s obligations under this warranty are specified and applied at its sole discretion, and warranty coverage is limited to repair or replacement of the defective product(s). Any and all costs of removal, installation or reinstallation; freight charges, incidental or consequential damages associated with the covered products are expressly excluded from this warranty.

The following items are exempt from Cognito limited warranty coverage: bushings, bump stops, tie-rod ends (Heim joints) and limiting straps. These parts are “consumables” and designed to wear as a normal part of their duty cycle, therefore they are not considered defective when worn. The aforementioned products are warrantied separately against defects in workmanship, for 60 days from the date of purchase. As a condition of warranty validation, respective Cognito suspension components must be installed as a complete system (not combined with non-Cognito hardware or ancillary parts). Any substitutions or omission of required components will void the warranty. Some minor cosmetic wear and imperfections may occur to parts during shipping, which is not covered under this warranty. This limited warranty does not apply to any components that have been subjected to collision damage, negligence, alteration, abuse, or misuse, and coverage does not extend to products manufactured by third-party companies. Cognito reserves the right to supersede, discontinue, or change the design, finish, part number and/or application of its parts when deemed necessary, without notice.

Return Policy

Product returns will not be accepted without prior written approval from an authorized Cognito representative. All products being returned must be shipped via trackable, prepaid freight. Returned products are subject to a 25% percent restocking fee. The eligible return period for products purchased directly from Cognito is 30 days from the verified date when the product(s) were originally received by the purchaser.

Product Safety Advisory

The installation of Cognito steering and suspension components will modify your vehicle’s original factory equipment and geometry, which may cause it to handle differently than a stock (unaltered) vehicle. Installation of these components is not intended to strengthen nor reinforce the vehicle’s frame, nor are they designed to increase rollover protection. It is necessary to periodically inspect all suspension and drive train components for proper attachment, torque specifications, operation, and for any potential unusual wear or damage. Installation of these parts will modify the height of the vehicle and may raise the center of gravity. Modifying vehicle height combined with off road operation may increase your vehicle’s susceptibility to rollover conditions, which may cause serious injury or death. Many states regulate allowable vehicle height modifications, and it is your responsibility to know and comply with the legal requirements specified by the laws where you reside. Modifications to your vehicle’s ride height may also affect the ride quality, driver input response, trackability and handling, and wear to your vehicle’s suspension components and tires.