

INSTALL INSTRUCTIONS FOR 75-5087

BEFORE YOU START

This intake kit may not fit with the following Aftermarket Parts installed:

Body Lift or Lowering Kit

Custom Hood

Throttle Body Spacer / Upgrade

REQUIRED TOOLS

- 8mm, 10mm, 11mm, 13mm Wrench/Socket
- T20 Torx
- Phillips Screwdriver
- Crescent Wrench
- Panel Popper
- Silicone Spray (Optional)

- Please read the entire product guide before proceeding.
- Ensure all parts are present.
- If you are missing any of the components, call our customer support at (909) 947-0015.
- Do not work on your vehicle while the engine is hot.
- Make sure the engine is turned off and the vehicle is in Park or the Parking Brake is set.

P	1	HOSE CLAMP, #56	AG1019-00
Q	6	BOLT, HEX, 1/4"-20 X 3/4	AI1068-00
R	4	WASHER, SPLIT LOCK, 5/16"	AI1309-00
S	8	WASHER, FLAT, 1/4"	AI1073-00
T	2	LOCKNUT, NYLON, 1/4"-20	AI1074-00
U	1	SNORKEL	AL1279S-00
V	2	SCREW, PAN, #8-32 X 3/4	AI1252-00
W	2	WASHER, FLAT, #8	AI1698-00
X	1	MAF BLOCK OFF PLATE	AI2020-00
Y	1	MAF PAD	AI1822-00
Z	1	MAF GASKET	AI1823-00
AA	1	GROMMET	AI1563C-00
AB	3	THREADED STUD, #10-24, 1.00"	AI2069-00
AC	1	LOOP CLAMP	AI1511-00
AD	3	WASHER, OVERSIZED, #10	AI2070-00
AE	3	LOCKNUT, NYLON, #10-24	AI1047-00
AF	3	PANEL RETAINER PINS	AI1567-00
AG	1	HOSE CLAMP, #104	AG1012-00

AM0358-00 REV-B 03/26/2018

AI1047-00
HP1524-00
AI1252-00
AI1698-00
AI1822-00
AI1823-00
AI2020-00
LHP0006-00
AI2005-00
AI2006-00
HP1521-00
AI1943-00
AI1766-02

DETAILED VIEW

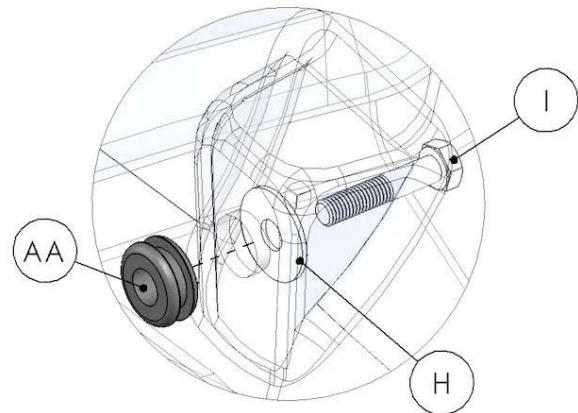

**DETAIL
A**

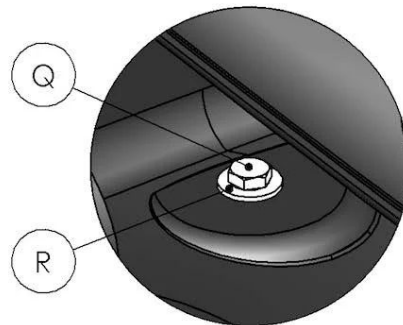

**DETAIL
B**

STEP 1

With the ignition switched off and the parking brake set, disconnect the negative battery cable on the driver's side.

IMPORTANT: Failure to disconnect the battery for a minimum of 2 hours may cause the Check Engine Light to illuminate upon completion of the installation or subsequent operation. **DO NOT SKIP THIS STEP!**

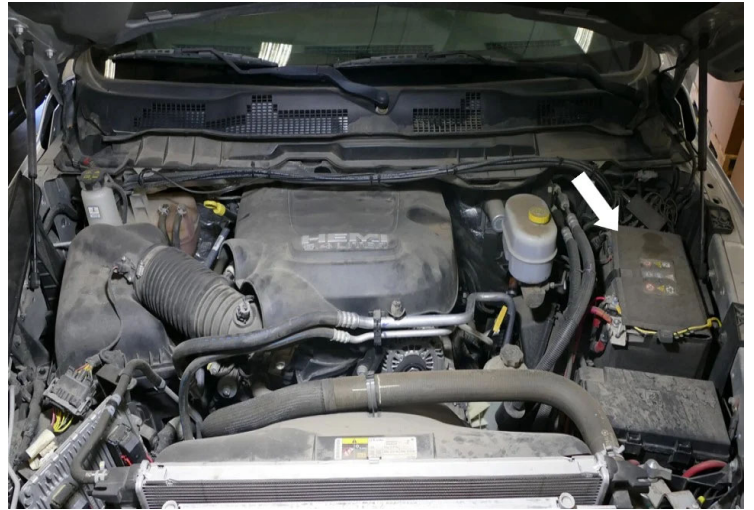

STEP 2

Lift up and pull out to remove the engine cover from the vehicle.

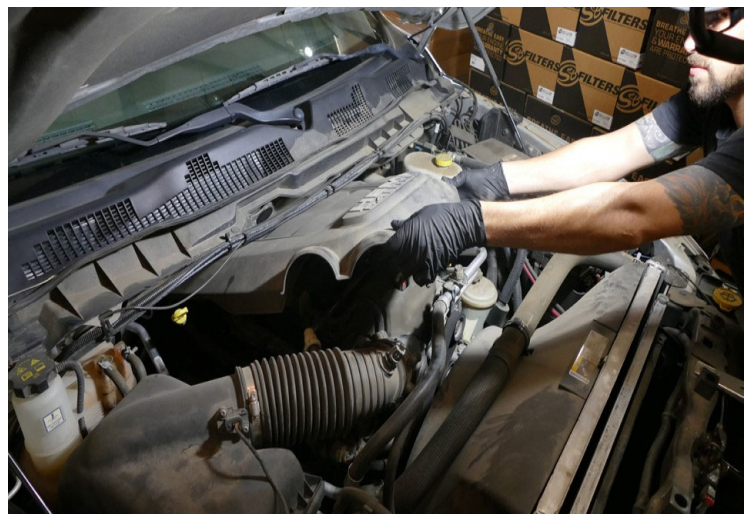

STEP 3

For **2014 - 2015 models** disconnect the electrical harness for both the MAP and IAT sensor on the intake tube and lid.

For **2016 and newer models** you only need to disconnect the IAT sensor on the intake tube. On the newer models, the MAP sensor was deleted by the factory.



STEP 4

Open the two plastic clips and disconnect the CCV line from the intake tube. Push the connector towards the intake tube then press the plastic tab to unlock the connector and pull out away from the tube to disconnect the CCV line.



STEP 5

Loosen the clamp at the

throttle body and intake box lid.



STEP 6

Remove the IAT sensor from the intake tube by pushing the sensor in to break the seal then rotating the sensor counterclockwise to unlock the sensor and pull the sensor out completely. Set the sensor aside it will be reused in Step 24.



STEP 7

If your vehicle is equipped with a MAP sensor. Carefully remove the MAP sensor from the intake box lid. It will be

reinstalled in Step 26.



STEP 8

Disconnect the A/C line bracket and tabs securing the A/C lines to the side of the intake box.

For **2014 - 2015 models** there is one bracket and two plastic tabs.

For **2016 and newer models** there are two brackets and two plastic tabs.



STEP 9

Unfasten the four clips to remove the intake box lid

from the vehicle.



STEP 10A

Lift the bottom half of the intake box up to get the intake box out of the grommets and rotate the intake box so the snorkel can clear the ECU and other brackets that are in the way. If you are still having issues getting the snorkel out, remove the filter and snorkel by pushing in the tabs, go to Step 10b for more details.



STEP 10B

(Optional) To remove the

snorkel attached to the intake box. Push in tabs inward and push out.



STEP 11

Remove the wheel liner. There is a combination of bolts and panel retainer pins that may need to be removed to lower the wheel liner. Do not forget to remove the two bolts that are mounted vertically that is attached to the intake box tray.



STEP 12

Remove the four bolts securing the intake box tray from the vehicle.

Note: For 2018 vehicles, disconnect the harness clip from the intake box tray.



STEP 12 (IMAGE 2)

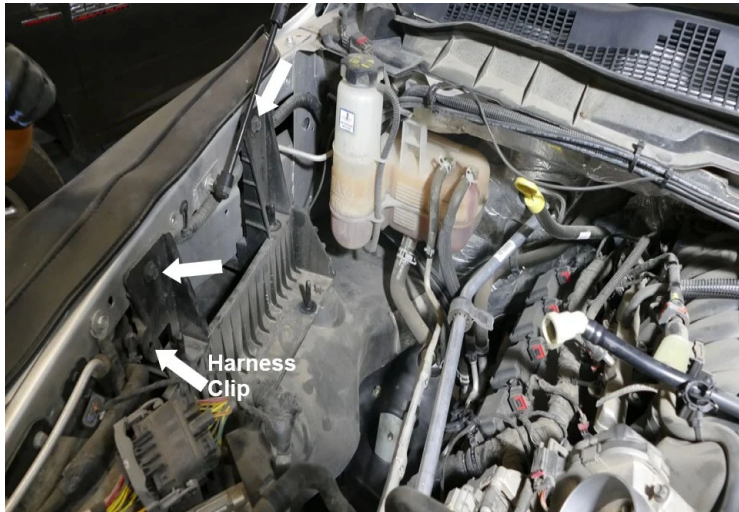

STEP 13

Install the IAT Sensor Adapter (M) by pressing it into the raised pad on the Intake tube (K). Align the tab on the adapter with the notch on the intake tube.



STEP 14

Install the Grommet (AA) into the Intake Box (F).



STEP 15

Install the Tube Seal (J) into the Intake Box (F).



STEP 16

Install the Threaded Studs (AB) into the inserts on the side of the Intake Box (F) until finger tight. Depending on your model's year you may require to install two or three studs. See Step 21 for A/C line configurations.



STEP 17

Determine if you want to install the Intake Box Plug (G) onto the Intake Box (F). See the "Intake Box Plug" note to decide the desired

setup.



STEP 17 (IMAGE 2)



STEP 18

For ease of installation, it is suggested to assemble the intake inside the vehicle. First place Snorkel (U) in a position close to the fender inlet then place the Intake Box (F) into the vehicle.



STEP 18 (IMAGE 2)

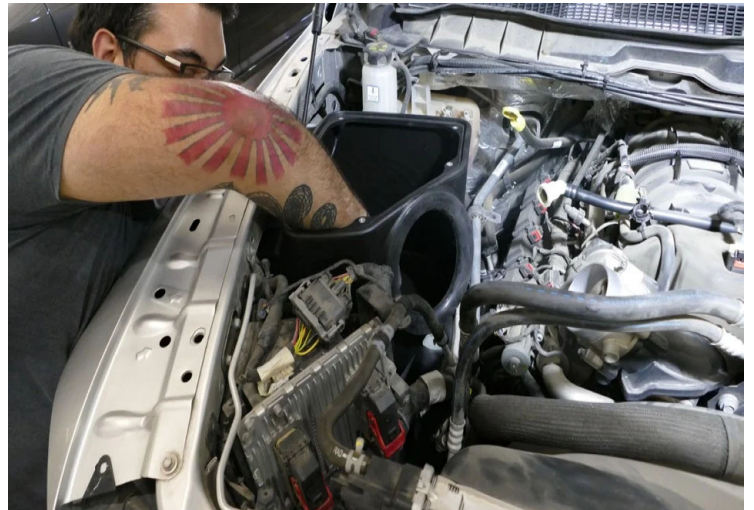

STEP 19

Align the Snorkel (U) with the Intake Box (F) and secure them together with 1/4"-20 Bolts (Q), 5/16" Split Lock Washers (R), 1/4" Flat Washers (S). Tighten all four 1/4"- 20 Bolts.



STEP 20A

Secure the Intake Box (F) to the fender with the M8 Bolt (I) and Flat Washer (H). Leave the bolts loose.



STEP 20B

From inside the wheel well, secure the Intake Box (F) to the frame with the M8 Bolt (I) and Flat Washer (H). Make any final adjustments if needed then tighten both bolts.



STEP 21

Secure the two A/C lines disconnected in Step 8. The lower A/C line with the Loop Clamp (AC), Washer (AD), and Locknut (AE). Align the stock A/C brackets on the higher A/C line and secure with the Washer (AD), and Locknut (AE).

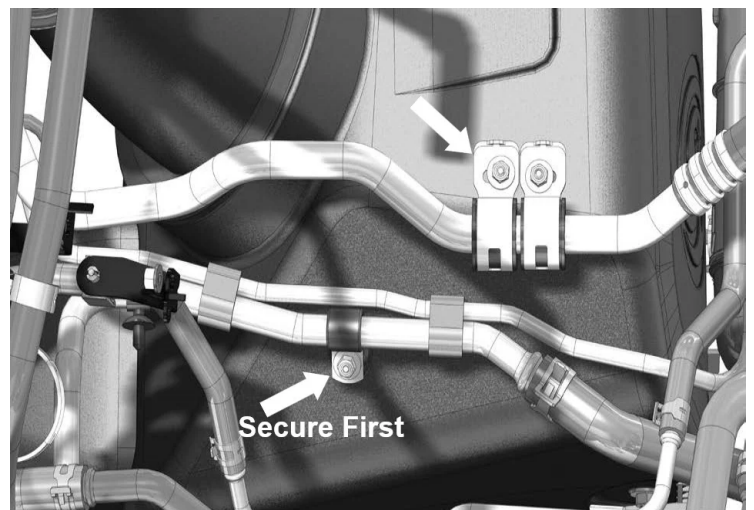

STEP 22

Slide the Coupler (O) onto the throttle body with the

Hose Clamps #56 and #60 (P & N). Only tighten the #56 Hose Clamp, leave the other one loose.

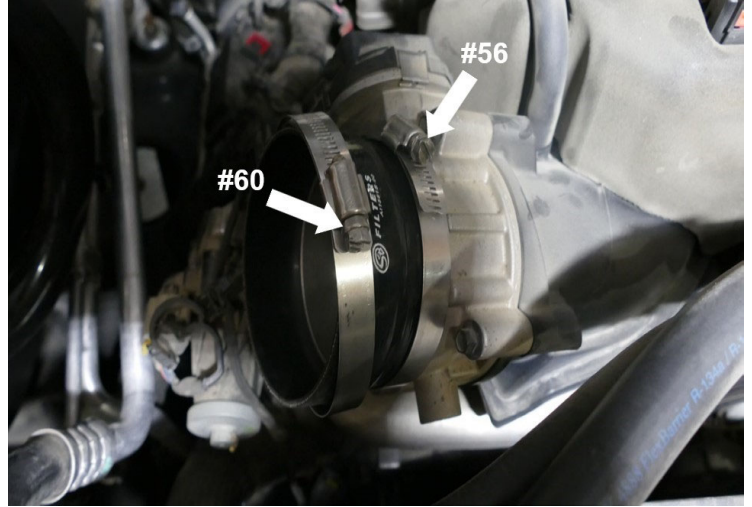

STEP 23

If necessary, spray some silicone lubricant around the Tube Seal (J) so the Intake Tube (K) can go through the tube seal easier. Feed the air tube through the tube seal from inside the Intake Box (F) then connect the other end of the intake tube into the Coupler (O). Tighten the #60 Hose Clamp (N).

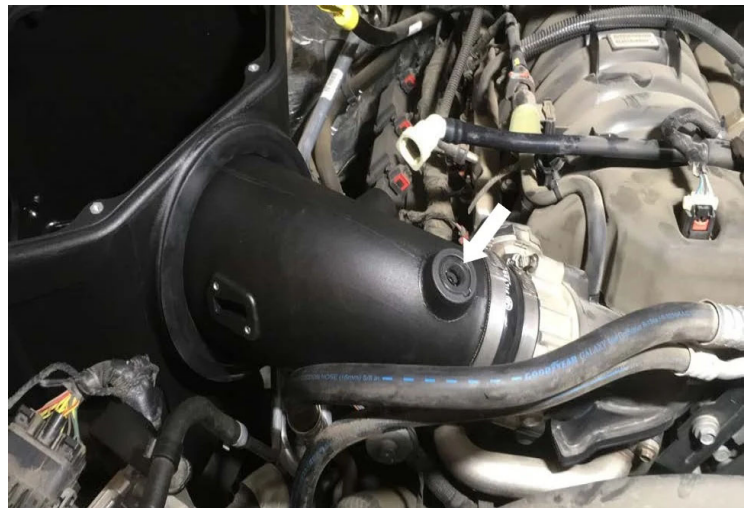

STEP 24

Install the CCV Fitting (L)

onto the Intake Tube (K) until hand tight, then use a crescent wrench and tighten it another one to two complete turns. Connect the CCV line to the CCV fitting and secure the plastic clips to the hoses.

IMPORTANT: Do not over tighten, as the Quick Connect Fittings can break or the threaded inserts may strip!



STEP 25A

Install the IAT sensor removed in Step 6. Line up the tab on the sensor in between the arrow and left of the locating tab then rotate the sensor clockwise until it gets to the right side of the locating tab.

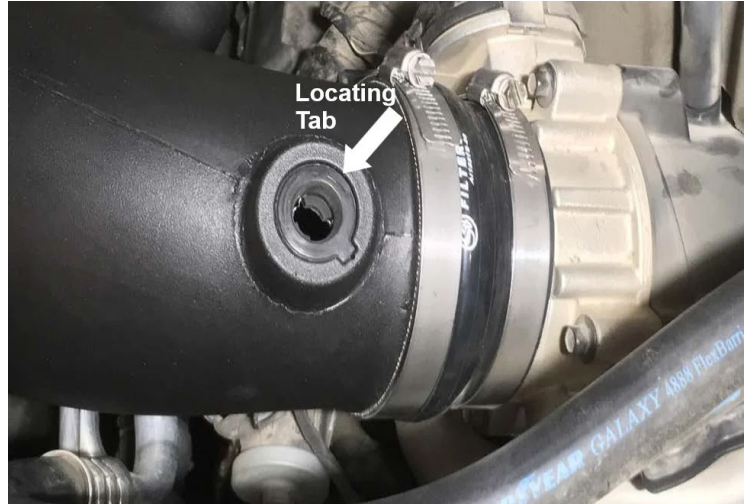

STEP 25B

Reconnect the electrical harness into the IAT sensor.



STEP 26A

For **2014 - 2015 models** carefully install the MAP sensor removed in Step 7 with the MAP Gasket (Z) and MAP Pad (Y) and #8-32 Screws (V).

For **2016 and newer models** go to Step 27.



STEP 26B

Reconnect the electrical harness into the MAP sensor.



STEP 27

2016 and newer models do not have a MAP sensor. Install the MAP Gasket (Z), MAP Block Off Plate (X) and #8-32 Screws (V) to block the opening.



STEP 28

Reinstall the wheel liner and the bolts. Use the Panel Retainer Pins (AF) to replace any pins broken during the removal process. Secure the wheel liner to the Airbox (F) with the 1/4"-20 Bolts (Q),

Flat Washers (S), and Locknuts (T). You will need two 11mm sockets, wrenches or a combination of the two to tighten both the bolt and locknut.



STEP 28 (IMAGE 2)



STEP 29

Install the Lid Seal (E) into the grooves on top of the Intake Box (F).



STEP 30

Place the Air Filter (C) into the Intake Box (A). Slide the Air Filter (D) onto the Intake Tube (K) and tighten the #104 Hose Clamp (AG) on the filter.



STEP 31

Peel off the protective covering on the Clear Lid (C).



STEP 32

Place the Clear Lid (C) on top of the Intake Box (F) and secure with the five #10-24 Lid Screws (A) and Lid Washers (B).



STEP 33

Reinstall the engine cover.



STEP 34

Reconnect the negative battery cable. Inspect your installation, make sure the kit is properly positioned and all fasteners are secured. Keep all stock parts in case you would ever need to reinstall the stock intake assembly. Affix the ID label near the intake kit. The installation is now complete.

