

# INSTALL INSTRUCTIONS FOR 75-5081

## BEFORE YOU START

- Please read the entire product guide before proceeding.
- Ensure all parts are present.
- If you are missing any of the components, call our customer support at (909) 947-0015.
- Do not work on your vehicle while the engine is hot.
- Make sure the engine is turned off and the vehicle is in Park or the Parking Brake is set.
- Kit may not fit with the following Aftermarket Parts installed: Body Lift or Lowering Kit, Custom Hood, Throttle Body Spacer/ Upgrade

## REQUIRED TOOLS

- 10mm, 13mm Wrench & Socket
- 5/16" Nut Driver & 1/4" Nut Driver or Flat Blade Screwdriver
- Phillips Screwdriver, Pliers or Channel Locks

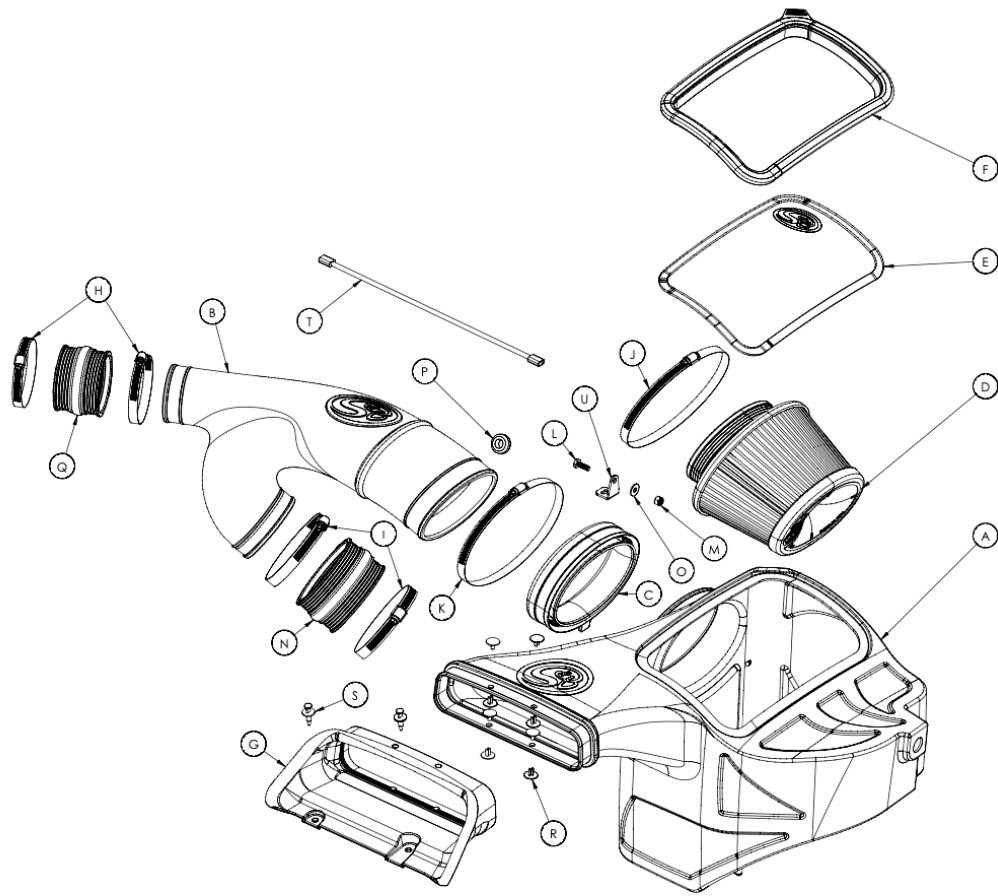

ITEM NO.	PART NUMBER	DESCRIPTION	QTY.
A	AL1246B-02	Air Box	1
B	AL1246-00	Intake Tube	1
C	AI1604C-00	Rubber Cuff	1
D	KF-1083	Air Filter	1
E	AI1790-02	Clear Lid	1
F	AI2536C-00	Snap-in Lid Seal	1
G	AI1758C-00	Front Inlet	1
H	AG1007-00	Hose Clamp, #52	2
I	AG1009-00	Hose Clamp, #72	2
J	AG1011-00	Hose Clamp, #88	1
K	AG1012-00	Hose Clamp, #104	1
L	AI1068-00	Screw, Hex Head, 1/4-20 UNC x .75, Gr 5, Zn Pltd	1
M	AI1074-00	Locknut, Nylon, 1/4-20 UNC, Zn Pltd	1
N	AI1333C-00	Coupler, Hump, 4.10 ID x 2.50 Long, Silicone	1
O	AI1535-00	Washer, Flat, M6, 18 mm OD	1
P	AI1563-00	Grommet, 1/2" ID x 1-1/16" OD, 7/16" Thk, 3/16" Panel	1
Q	AI1601C-00	Silicone Coupler	1
R	AI1762-00	Rivet, Interlocking Shank, 1/4" dia x .50-.81" Grip	8
S	AI1763-00	Plastic Rivet, 11/16 dia head, 1/4 dia x 7/8 long stem	2
T	AI1969-00	IAT Sensor Harness Extension, 14" Long	1
U	AI1970-00	Vacuum Line Support	1

## STEP 1

With the ignition switched off and the parking brake set, disconnect the negative

battery terminal on the battery.

**IMPORTANT:** Failure to disconnect the battery for a minimum of 2 hours may cause the Check Engine Light to illuminate upon completion of the installation or subsequent operation. **DO NOT SKIP THIS STEP!**



## **STEP 2**

Loosen the hose clamp by the stock airbox and pull the tube out.



## STEP 3

Loosen the hose clamp at the tube leading to the turbo inlet on the passenger side.



## STEP 4

Loosen the hose clamp at the tube leading the turbo inlet on the driver side.



## STEP 5

Unhook the two latches on the stock airbox.

For **2017 3.5L Ecoboost Only**. Disconnect the clip securing the vacuum line on the stock airbox.

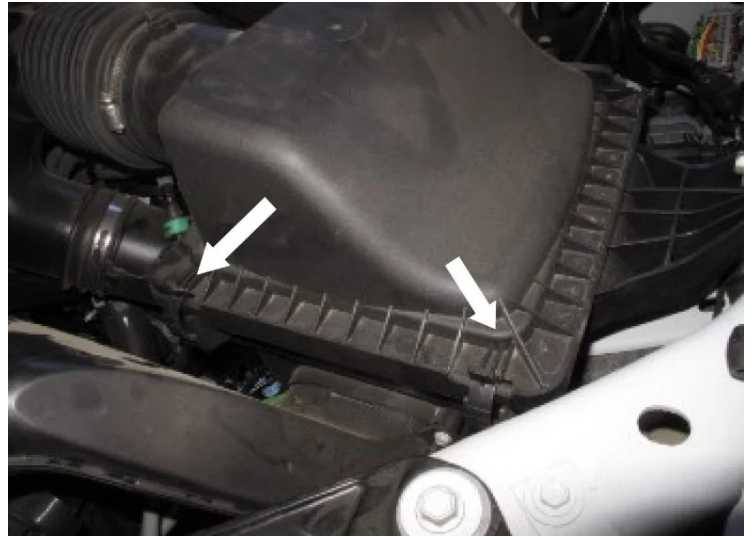

## STEP 6

Lift and remove both the lid and stock air filter.



## STEP 7

Remove the IAT sensor from the stock air tube by turning the sensor counter-clockwise and pulling out. You should be able to feel the sensor unlock as you are making the turn. Push down on the wire harness

connector tab to remove the wiring harness from the sensor.

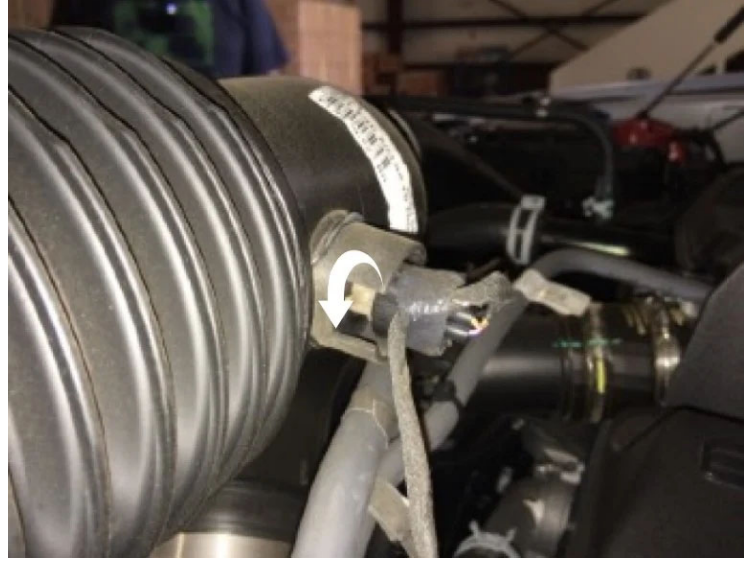

## STEP 7 (IMAGE 2)

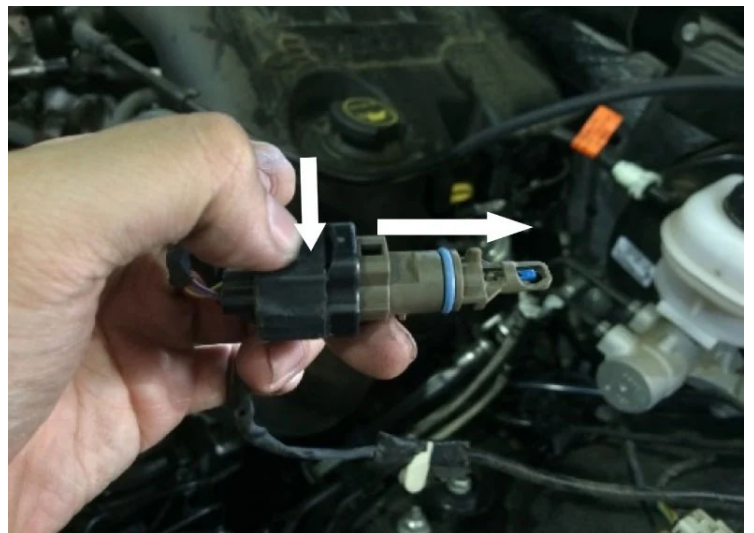

## STEP 8

Lift up and remove the stock air tube.

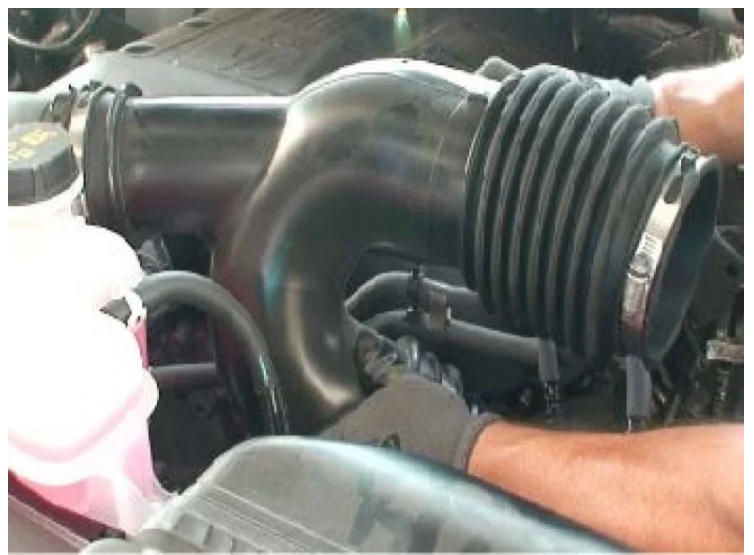

## STEP 9

Remove the retaining bolt on the stock airbox using a 13mm socket.

**Note:** The retaining bolt will be reused in Step 22.



## STEP 10

Remove the plastic rivets on the stock air inlet using a flat head screwdriver.



## STEP 11

Disconnect the two-wire harness clips on the stock airbox.





## STEP 12

Lift and remove the stock airbox.



## STEP 13

Remove the grommet and metal bushing from the stock airbox. Removing the metal bushing first will make removing the grommet easier.

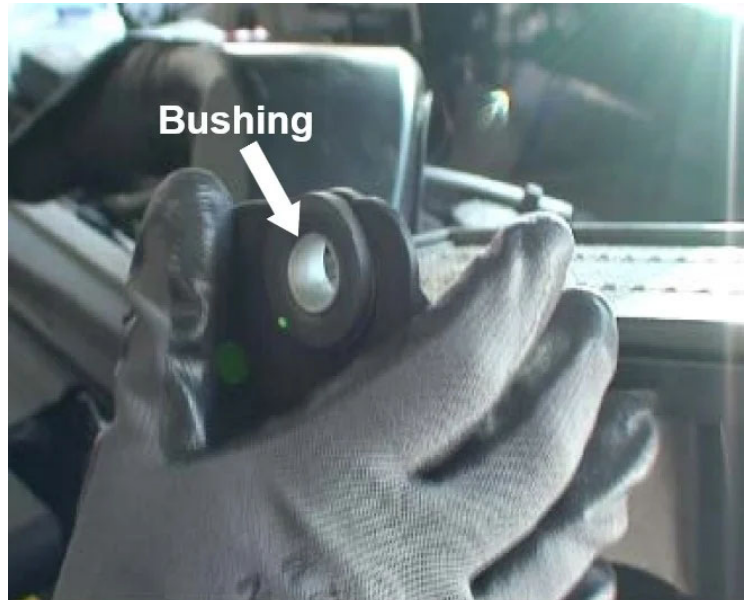

## STEP 14

Install the grommet into Airbox (A) first and then install the metal bushing from the inside.



## STEP 15

For **2017 3.5L Ecoboost Only**. Install the Vacuum Line Bracket (W) with the 1/4-20 Screw (X), Washer (Y) and Locknut (Z).



## STEP 16

Install the Cuff (C) and #104 Hose Clamp (L) onto the side of the Airbox (A). Make sure that the rubber pull tab on the tube seal is on the bottom. Tighten the hose

clamp.



## STEP 17

Install the Front Inlet (G). Use the supplied Plastic Rivet (H) to secure the front inlet to the Airbox (A). Use two plastic rivets on each hole and pinch them together to lock them in place.



## STEP 18

Install the Grommet (V) into the Intake Tube (B).



## STEP 19

Install the Hump Coupler (P) with Hose Clamp #52 (R) into the Intake Tube (B) that leads to the passenger side. **Do not tighten the hose clamps.** Install the Straight Coupler (U) and Hose Clamp #72 (T) that leads to the driver's side. **Do not tighten the hose clamps.** To make the installation onto the turbo inlet tubes easier, try to slide the coupler in over the air intake tube as much as possible.

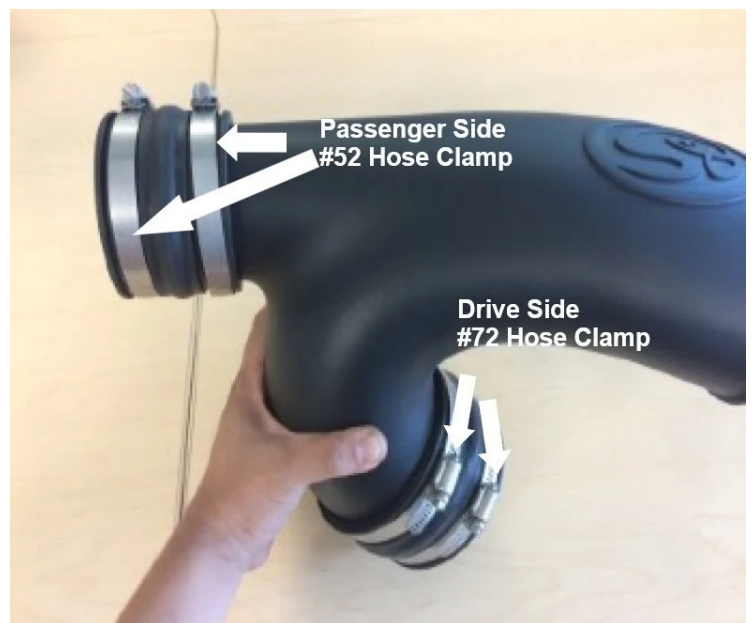

## STEP 19 (IMAGE 2)



## STEP 20

**For 2.7L EcoBoost Only.** You will need to reroute the vent hose. Remove the vent hose connector by pinching the red clip and pushing in through the connector. Reroute the vent hose as shown. Reorient the black plastic hose clip and snap in place the two vent hoses. Then reinstall the red connector.



## STEP 20 (IMAGE 2)

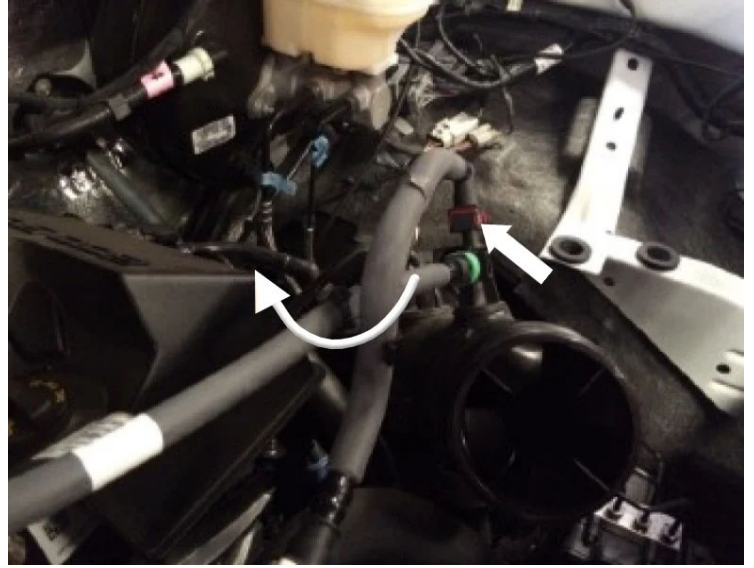

## STEP 20 (IMAGE 3)



## STEP 20A

Locate the CCV hose on the lower intake tube, highlighted with the red arrow.



## STEP 20B

Disconnect the quick disconnect by rotating the tab on the quick disconnect. Removing the engine cover improves access, but is not necessary.



## STEP 20B (IMAGE 2)



## STEP 20C

Orient the CCV tube insert, the angled cut on the insert should be facing the turbo/firewall.



## STEP 20D

Insert the CCV tube insert until the insert bottoms out against the quick disconnect.

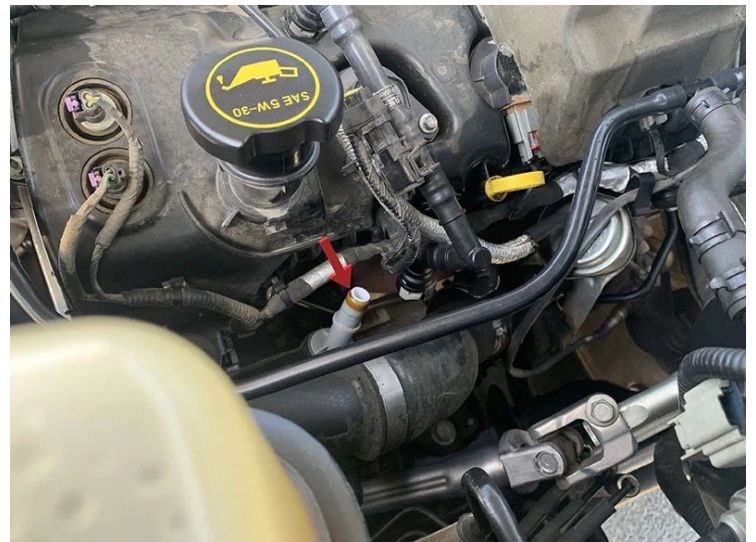



## STEP 20E

Reattach the hose and reinstall the cover, if previously removed.

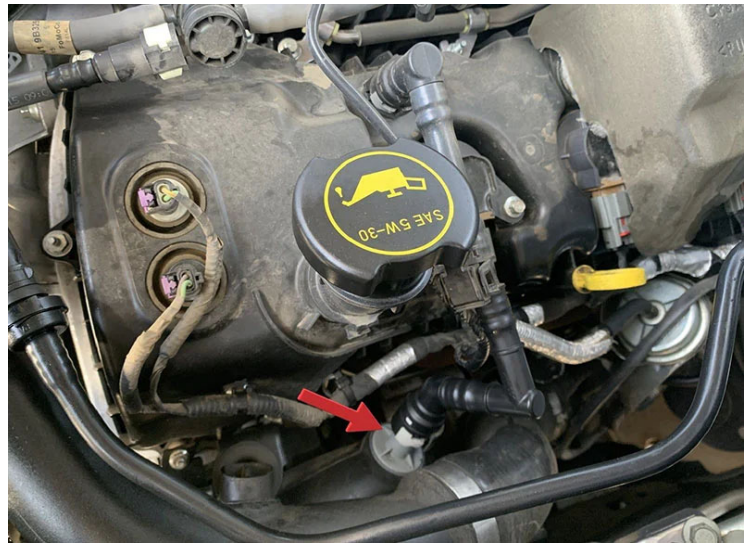

## STEP 20E (IMAGE 2)



## STEP 21

Install the Airbox (A). Make sure that the box prongs are aligned with the factory grommets. Push down on the airbox to make sure that the prongs are completely seated.



## STEP 21 (IMAGE 2)



## STEP 22

Reinstall the retaining bolt removed in Step 9 and tighten the bolt to secure the Airbox (A). Install the retaining bolt from inside the airbox.



## STEP 23

Install the IAT Sensor into the Intake Tube (B). Make sure to remove the IAT Sensor O-Ring prior to installing. Use a twisting motion to make it easier to guide the sensor into the grommet. Make sure that the sensor is seated all the way so that the sensor tab is touching the grommet and is lined up with the triangle mark located on the air intake tube.



**STEP 23 (IMAGE 2)**



**STEP 23 (IMAGE 3)**



## STEP 24

Place the Air Filter (D) inside the Airbox (A). Turn the filter sideways and slide it into the box. Do not tighten the hose clamp.



## STEP 25

Feed the Intake Tube (B) through the Cuff (C) and into the airbox until the air filter fits up to the bead. As you are feeding, try to align the air intake tube with the turbo inlet tubes.

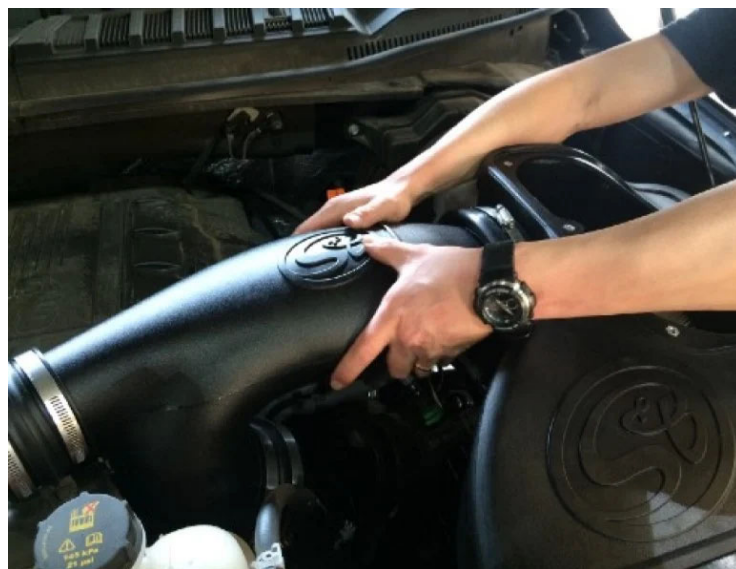

## STEP 26

Once the bead is up to the Cuff (C). Slide the Air Filter (D) onto the Intake Tube (B).



## STEP 27

Tighten the Hose Clamp #88  
(K) at the Air Filter (D).



## STEP 28

Slide the Straight Coupler (U) over the driver side turbo inlet tube on the bottom. Leave the hose clamps loose for now.



## STEP 29

Slide the Hump Coupler (P) over the passenger side turbo inlet tube.

## STEP 30

Tighten both #52 Hose Clamps (R).



## STEP 31

Tighten both #72 Hose Clamps (T) on the driver's side.





## STEP 32A

For **2015-2016 Models and 2017 2.7L EcoBoost Only**. Reconnect the wiring harness back into the IAT sensor.



## STEP 32B

For **2017 3.5L EcoBoost Only**. Connect one end of the IAT Sensor Extension Harness (AA) into the stock IAT harness and the other end into the IAT sensor. Use zip ties to secure the extension harness from any hot surfaces and moving components that may cause damage.



## STEP 33A

**For 2015-2016 Models and 2017 2.7L EcoBoost Only.**

Insert the two-wire harness clips disconnected in Step 11 into the holes on the side of the Airbox (A).

**For 2017 3.5L EcoBoost Only.** Insert one wire harness clip into the hole under the S&B Logo and use zip ties secure the other wire harness clip away from any hot surfaces and moving components that may cause damage.



## STEP 33B

**For 2017 3.5L EcoBoost Only.** Reconnect the clip securing the vacuum line into the slot on the Vacuum Line Bracket (W).



## STEP 34

Use the two provided Plastic

Rivet (J) to secure the Front Inlet (G) onto the radiator cover. Firmly push down on the center pin of the plastic rivet until it locks into the closed position.



 **STOP! READ  
THIS BEFORE  
CONTINUING THE  
INSTALL**

If your kit came with our new snap-in lid design, please proceed to **STEP 38** to install your snap-in lid. If your lid is the traditional screw in lid, please proceed to the next step.

## **STEP 35**

Remove the protective

covering from the Clear Lid  
(E).



## STEP 36

Install the Lid Seal (F)  
around the Clear Lid (E).



## STEP 37

Place the lid on top of the Airbox (A) and secure the lid using the six provided 10-24 Screw (N) and Sealing Washer (M). **Do not overtighten.**



## STEP 38

For Snap-In Lids Only

Remove the protective covering from the Clear Lid.



## STEP 39

For Snap-In Lids Only

Stretch silicone lid seal around the perimeter of the clear lid. It should be a snug fit.



## STEP 40

For Snap-In Lids Only

The notch on the lid and the tab of the lid seal should mate in the same corner.



## STEP 41

Reconnect the negative terminal on the battery. Inspect your installation, make sure the kit is properly positioned and all fasteners are secure. Keep all stock parts incase you would ever need to reinstall the stock

intake. The installation is now complete.

