

# CURRENTLYNC<sup>®</sup>

## HEAVY DUTY STEERING

### RJ-442100-101 JEEP JT WRANGLER & JT GLADIATOR CURRENTLYNC<sup>®</sup> STEERING SYSTEM INSTALLATION INSTRUCTIONS & TECHNICAL MANUAL



Thank you for purchasing our Currectlync<sup>®</sup> heavy duty steering components for your Jeep JL Wrangler or JT Gladiator! Using basic hand tools, these components directly replace your factory steering components and include the necessary bracket kits for relocating and reattaching your steering stabilizer shock.

**NOTES: no additional bump stop extension over stock is required for the sake of the drag link, however, when used with NO lift, vehicles will require bump stop extention for clearance of the relocated steering stabilizer shock. Required amounts: 3.6L & 2.0T = 1 1/4", diesel = 1/8", 392 = 0". Stabilizer brackets in this kit are for use with a traditional steering stabilizer shock only - not for use with Ram Assist! Always articulate test before calling it done!**

#### Kit Includes

RJ-442101-101	Tie Rod Assembly	RJ-441102-101	JL/JT Steering Stabilizer Shock High-Mount Relocation Bracket
RJ-442103-101	Drag Link Assembly	RJ-441108-101	Steering Stabilizer Shock Bracket Kit

#### Tools Required

Basic SAE and Metric Hand Tools    Shorty Sledge Hammer    Pickle Fork    Tape Measure    Needle Nose Pliers    Torque Wrench    Grease Gun

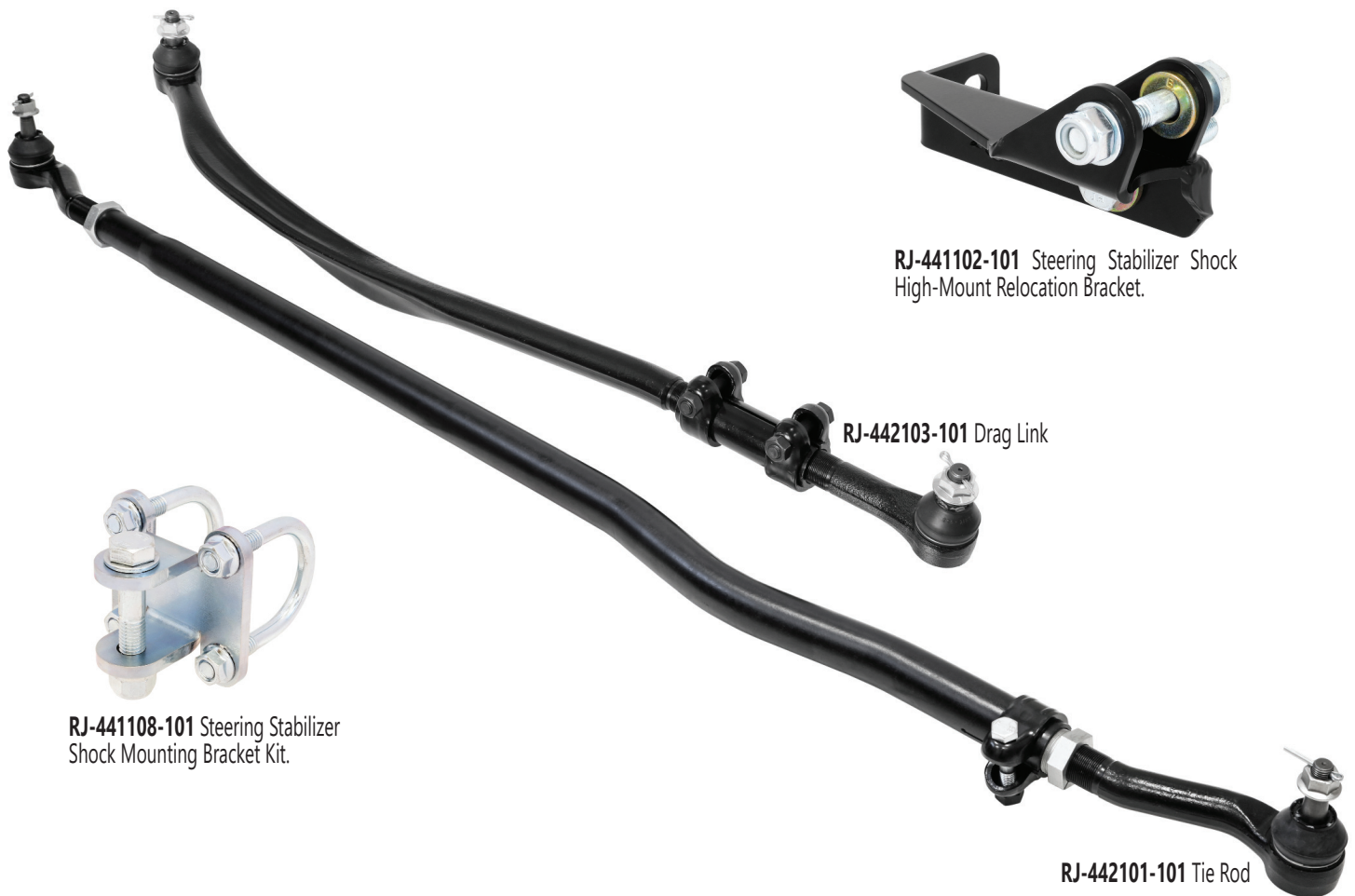

RJ-441102-101 Steering Stabilizer Shock High-Mount Relocation Bracket.

RJ-442103-101 Drag Link

RJ-441108-101 Steering Stabilizer Shock Mounting Bracket Kit.

RJ-442101-101 Tie Rod



[WWW.ROCKJOCK4X4.COM](http://WWW.ROCKJOCK4X4.COM)

@ROCKJOCK4X4   
 /ROCKJOCK4X4   
 /ROCKJOCK4X4BYJOHNCURRIE

### Step 1

We'll start the new Correctlync Steering installation by removing the stock steering stabilizer shock attaching bolt and nut from the passenger's side of the stock tie rod using a 18mm wrench or socket.



### Step 2

Next, with an 18mm wrench or socket, remove the bolt at the opposite end of the steering stabilizer shock, that attaches the shock to the axle housing bracket.

### Step 3

You may now remove the shock from the brackets and set the shock aside.



#### Step 4

With a 15mm wrench or socket, remove all of the bolts that attach the factory steering stabilizer shock axle bracket to the axle, and remove and discard the bracket.

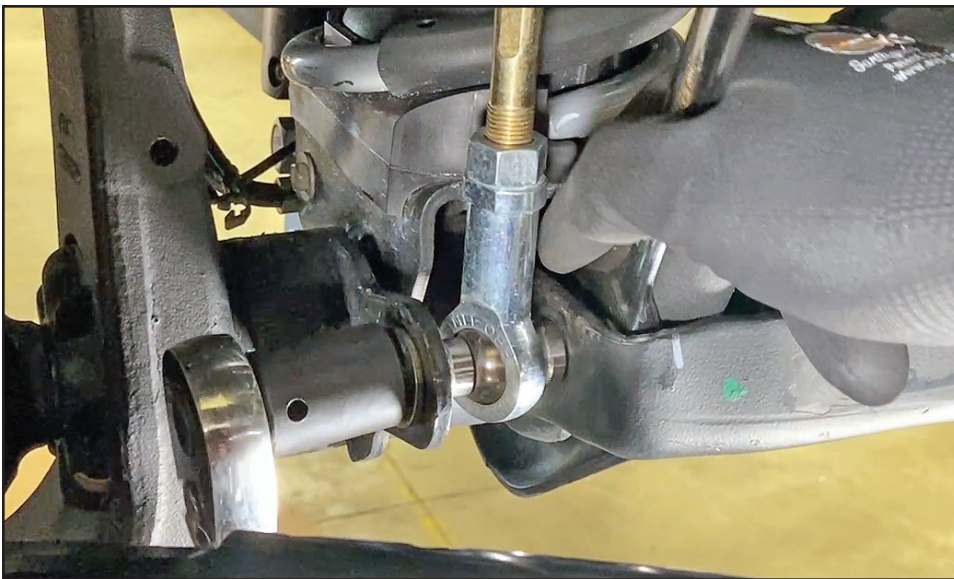
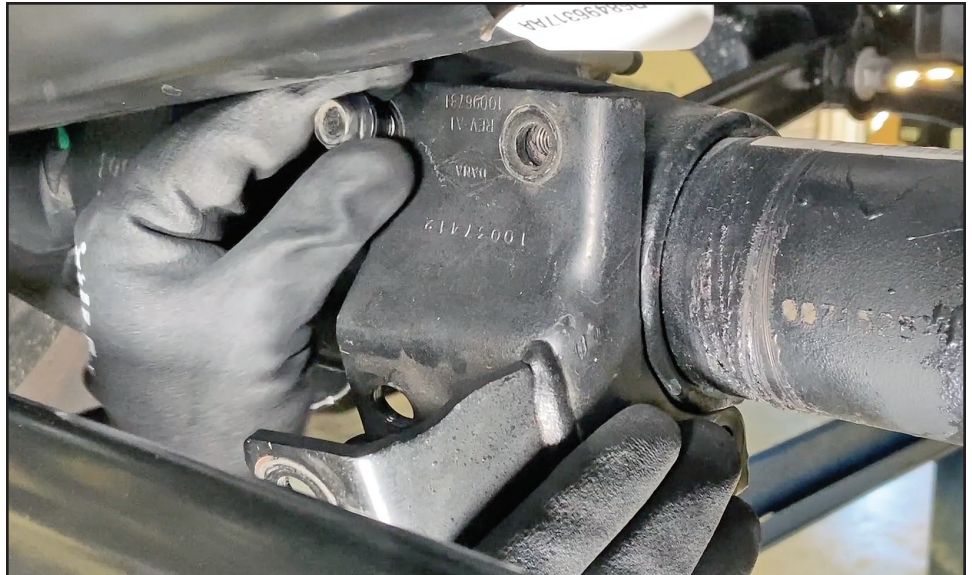

#### Step 5

Back to the passenger's side, remove the hardware that attaches the bottom of the sway bar link to the axle.

In our example, this required a 3/4" wrench & socket because an Antirock sway bar was installed. On a factory vehicle, this would require 18mm tools.

#### Step 6

Using a 21mm wrench or socket, remove the front trac bar bolt, being mindful that the vehicle may shift when this bolt is removed. Retain the flag nut for reuse.

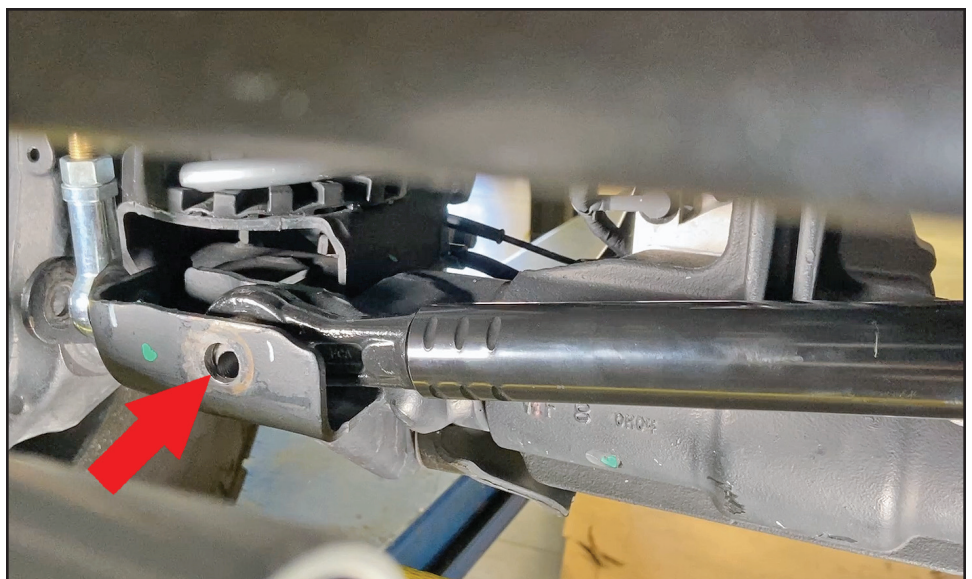

### Step 7

Install the new Steering Stabilizer Shock High-Mount Relocation Bracket using the new 14mm bolt and washer included in the kit. Reuse the factory flag nut on the back side.

This bolt becomes your new trac bar bolt.

Snug, but do not torque the bolt at this time.

NOTE: getting the trac bar bolt back in may require having a friend push the body of the vehicle around to help realign the hole, or, a ratchet strap may be used.

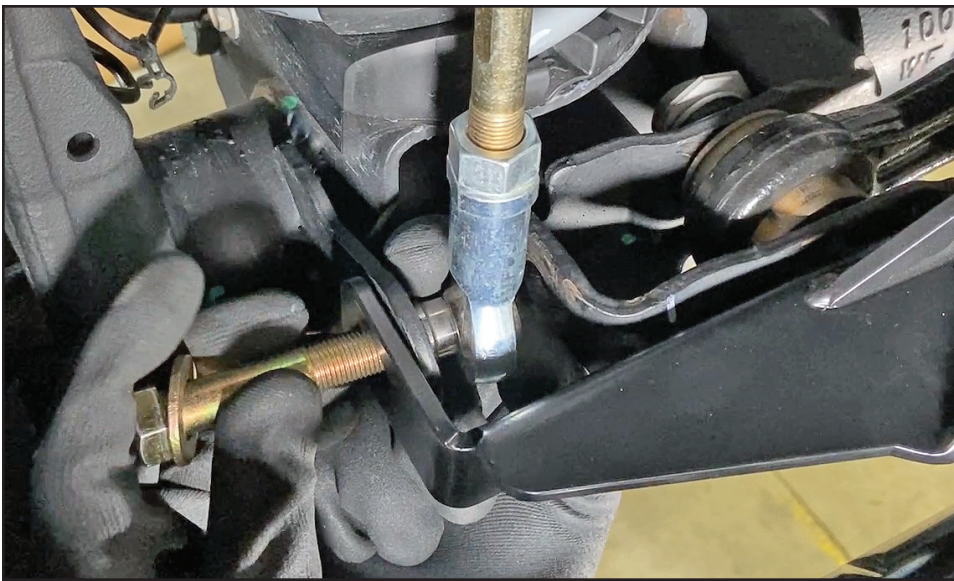

### Step 8

At the other end of the new Steering Stabilizer Shock High-Mount Relocation Bracket, you'll notice that it lines up with the bolt hole for the bottom of the sway bar link.

### Step 9

Reinstall your sway bar link rod hardware thru the outside of the new bracket and torque the bolt to 85 ft. lbs.

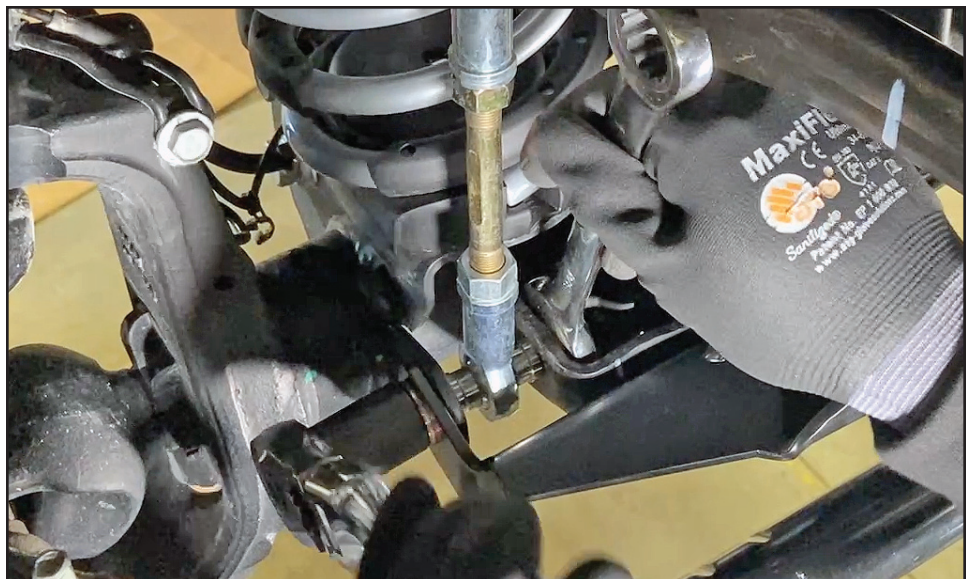

### Step 10

Now go back and torque the trac bar bolt to 125 ft. lbs. with a 22mm socket.

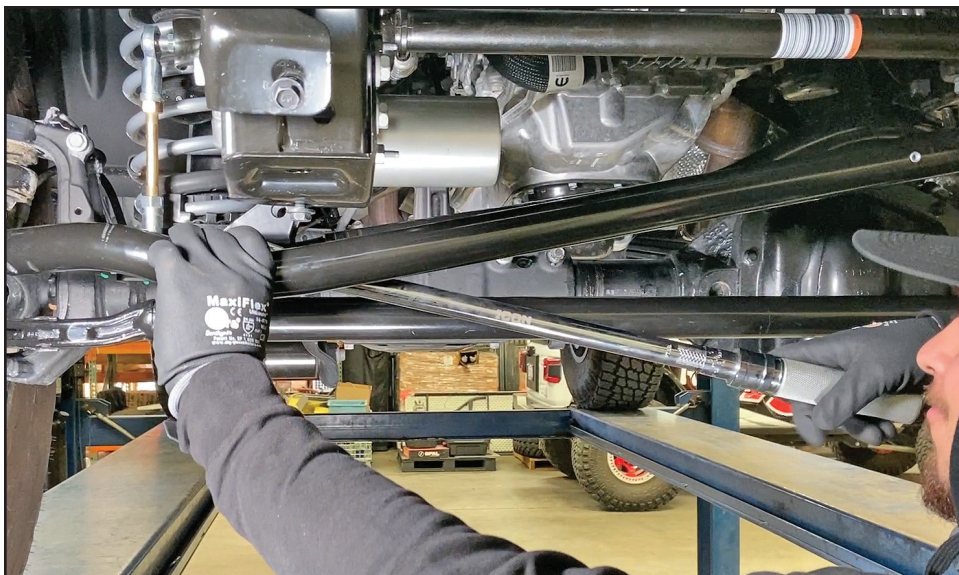

### Step 11

In the new Steering Stabilizer Shock High-Mount Relocation Bracket Kit, you will find new hardware for attaching the steering stabilizer shock to the new bracket.

Note the orientation of the stabilizer shock when reinstalling - it will only install one way as one bushing inner sleeve is wider than the other.

### Step 12

Using a 19mm wrench and socket, install the bolt and nyloc nut and torque to 60 ft. lbs.



### Step 13

Now we'll move on to removing the stock tie rod from the passenger's side knuckle. Remove the tie rod end attaching nut with a 21mm wrench and a 10mm wrench on the stem of the rod end.



### Step 14

To break the tie rod end free from the taper, we find it easiest to just strike the end of the steering arm with a short sledge hammer to jar the taper loose. A pickle fork may also be used here. Leave the nut on loosely while doing this so that the tie rod does not fall and hit you. After it's broken loose, go ahead and remove the tie rod end from the knuckle.

### Step 15

Repeat this rod end removal process on the other side and then remove the tie rod from the vehicle.

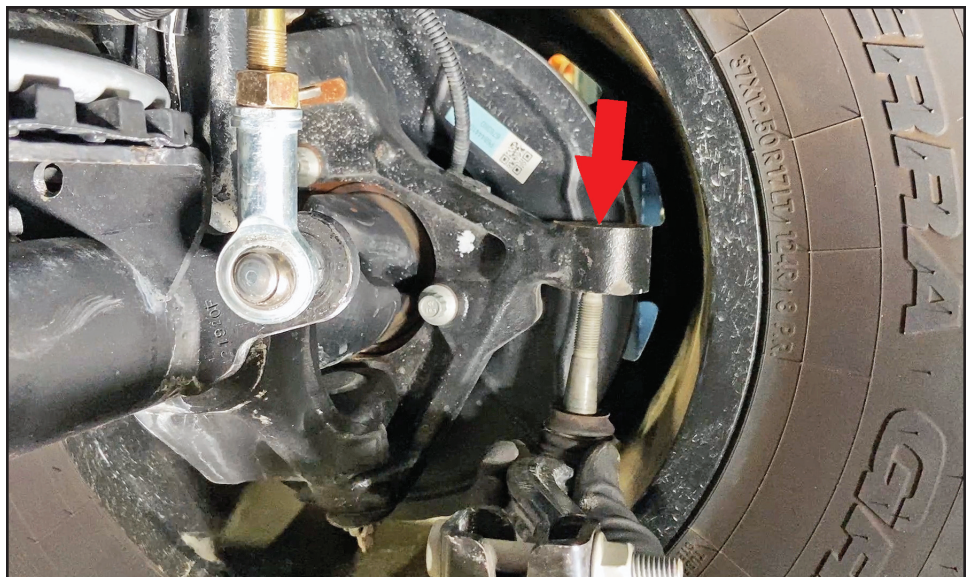

## Step 16

With the same tools, repeat the rod end removal process for the drag link end at the passenger's side wheel....



## Step 17

...and then at the pitman arm.

## Step 18

We use the short sledge hammer at the pitman arm as well, but, again, a pickle fork may also be used.

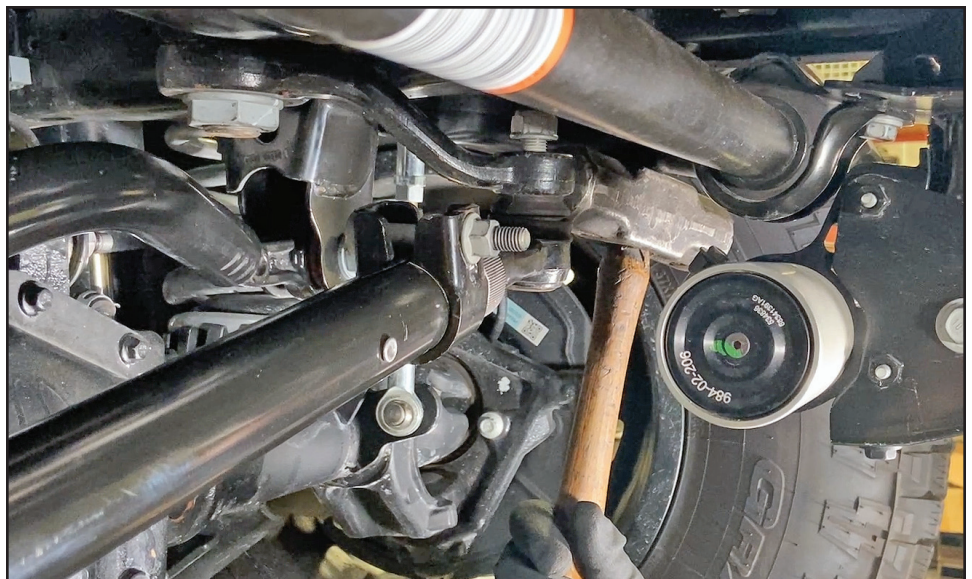

### Step 19

Remove the drag link from the vehicle.

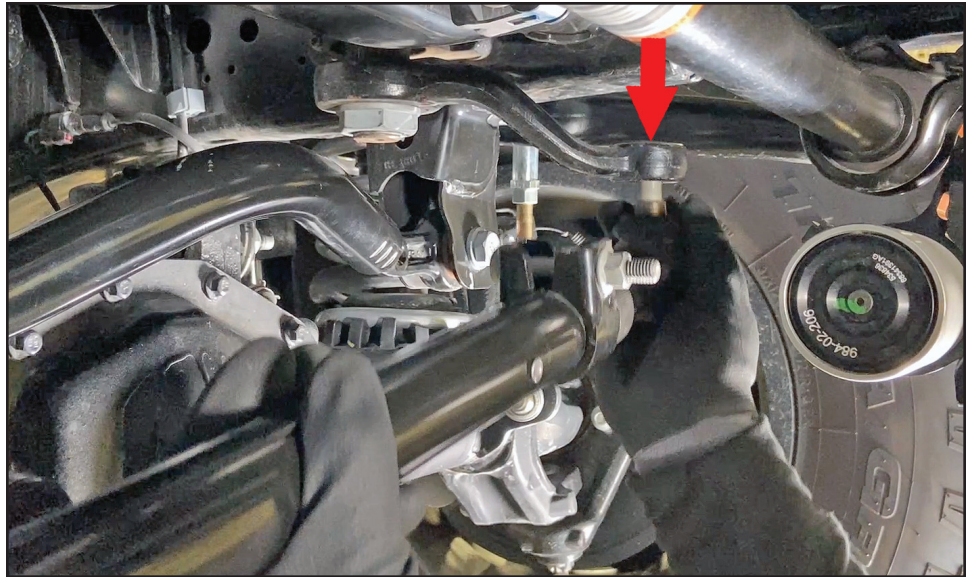

### Step 20

Adjust your new drag link's center to center dimension per the Tech Tip below. Loosen the adjuster hardware with an 18mm and a 19mm wrench if necessary. Make sure you keep the amount of exposed thread that is sticking out of the adjuster as even as possible.



## TECH TIP



See the guide below for drag link adjustment measurements.

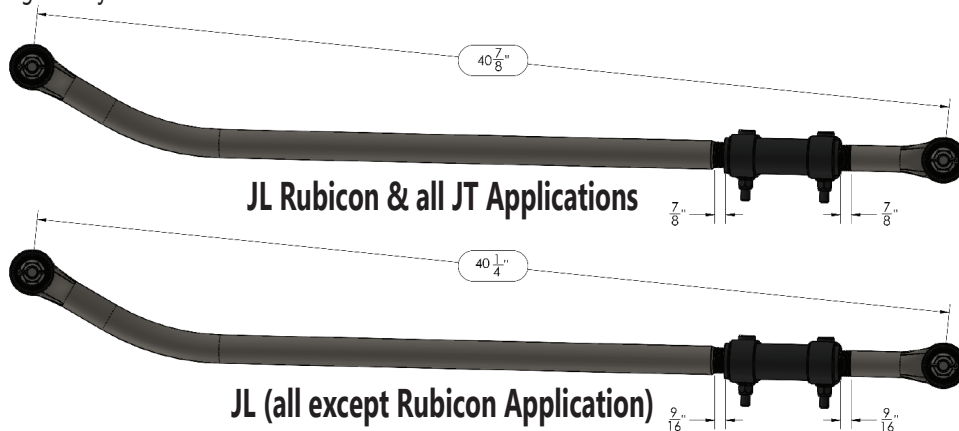

## Step 21

Install the new drag link at the passenger's side steering knuckle (but do not tighten or torque). And then at the pitman arm (again, do not tighten or torque).

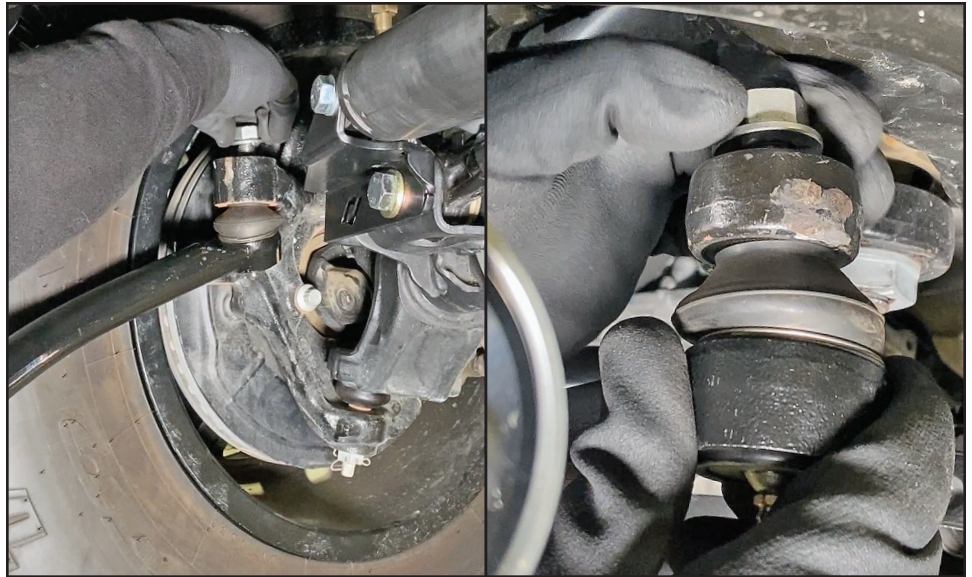

## TECH TIP



# IMPORTANT!!!

When installing the new drag link, it is imperative that you clock it properly for clearance. After the unit is adjusted at the alignment shop, the technician must follow these instructions.

In the application (shown in the diagram to the right) of a vehicle with the stock front axle and stock pitman arm, with the vehicle sitting at ride height, the rod end at the pitman arm, after alignment, must be rolled forward, as shown, before the clamp bolts are torqued down.

Additionally, the rod end at the knuckle must be positioned roughly neutral at ride height.

Torque the adjuster clamp bolts to 60 ft. lbs.

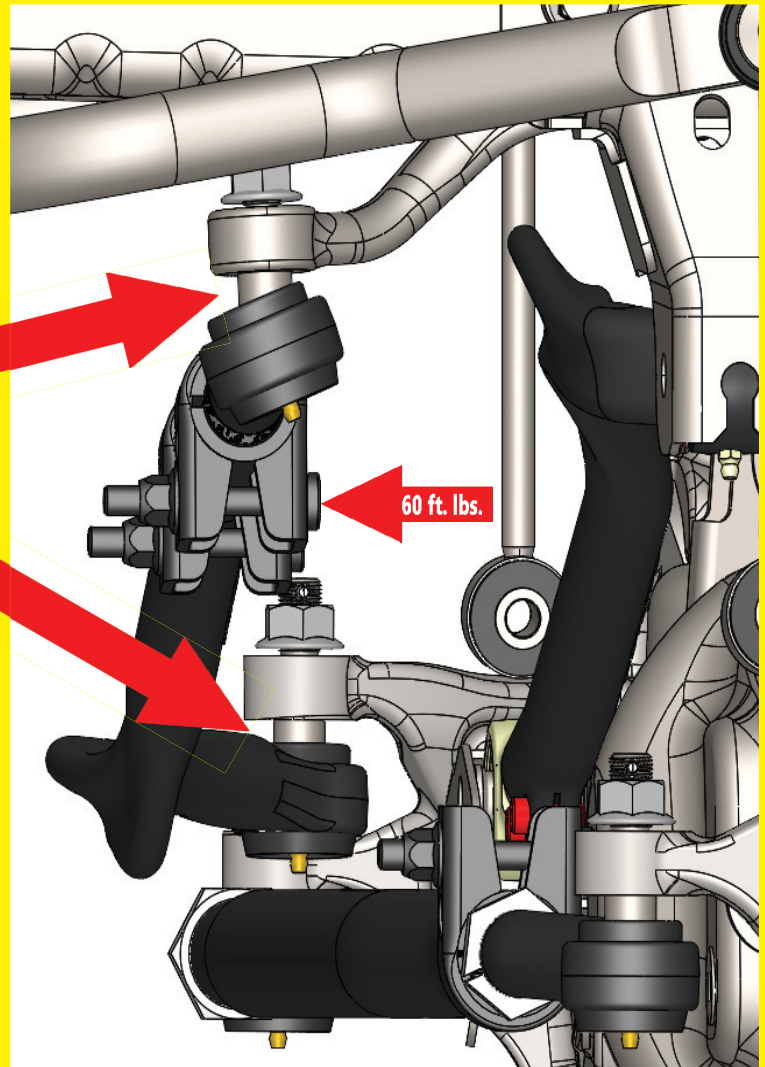

## Step 22

To prepare for installation, adjust the new tie rod's length to suite your vehicle model via the double adjuster nut and a 1 1/2" wrench. Again, make sure you keep the amount of exposed tie rod end thread that is sticking out of the tie rod as even as possible from side to side. See the Tech Tip on the next page.



# TECH TIP



See the guide below for tie rod adjustment measurements. Pre-adjust the passenger's side of the tie rod to the dimensions illustrated below (RH side shown below) before installing the unit into the vehicle. After installation, do the rest of your adjustments with the double adjuster on the driver's side.

**Do not install the unit and then use a pipe wrench, etc. to adjust the tie rod's length - we will not warranty damage to the tie rod's finish!  
If you have trouble adjusting the passenger's side end, wrap the tie rod in cardboard, etc. and put the unit in a vice!**

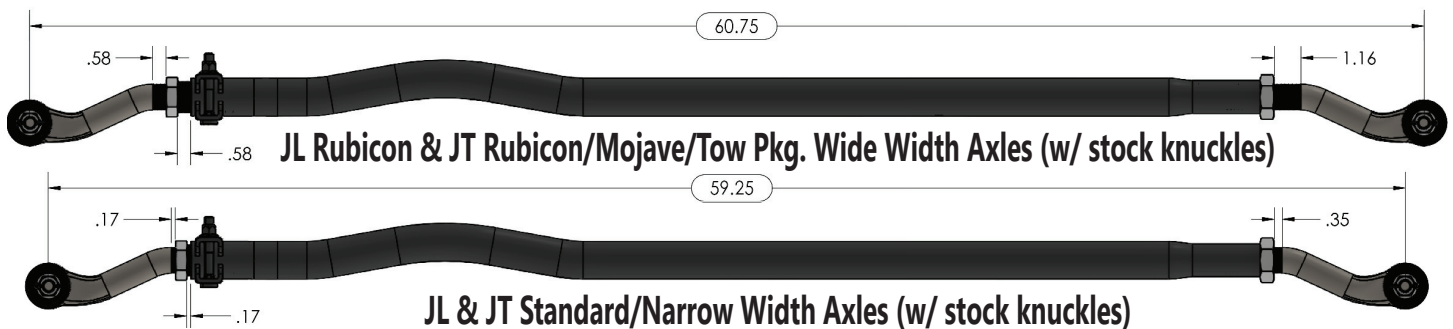

## Step 23

Next, insert the new tie rod at the passenger's side knuckle...

### Step 24

...and then at the driver's side knuckle.

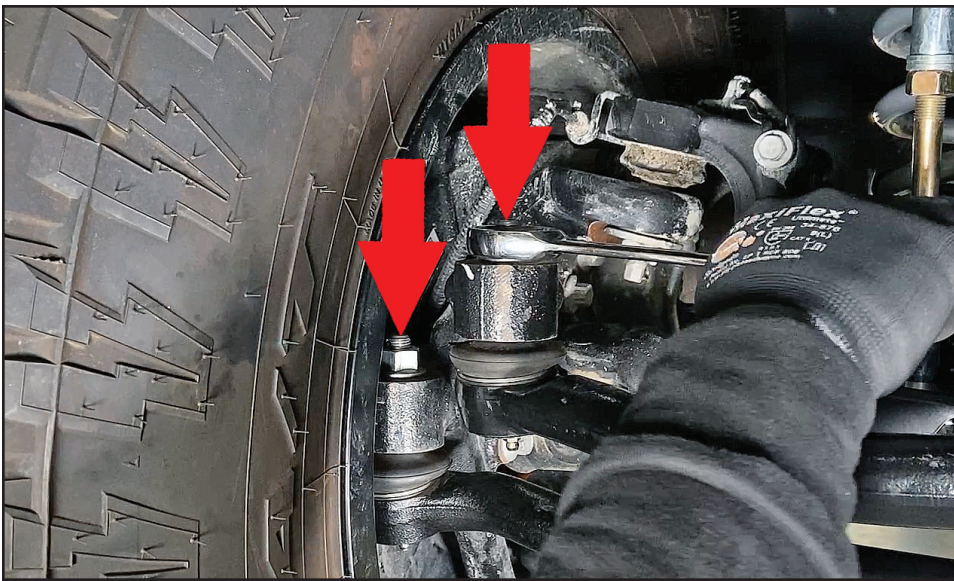
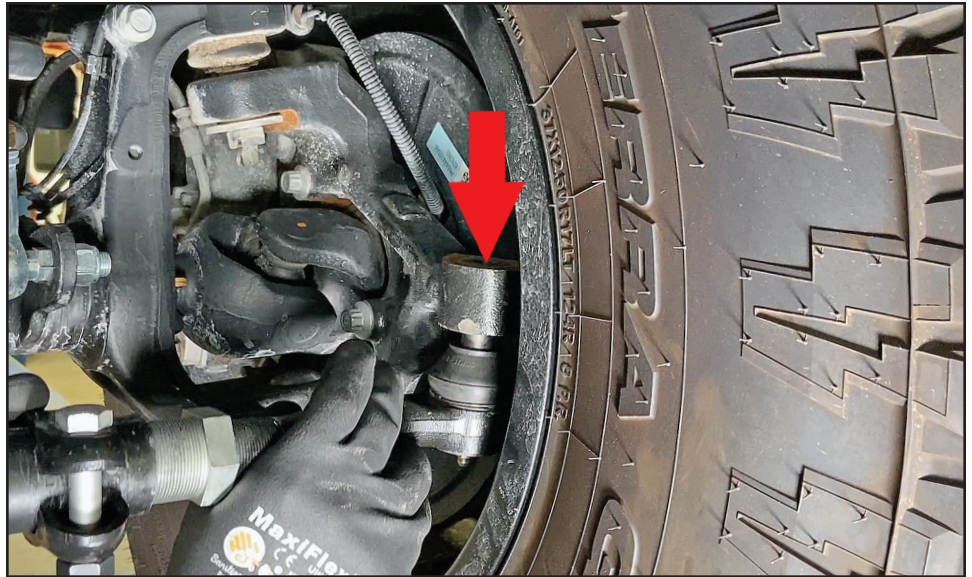

### Step 25

Now go back and tighten and torque all of the new rod end nuts at the steering knuckles (2 on the passenger's side knuckle, one on the driver's side knuckle) to 50ft. lbs. with a 21mm wrench and socket.

### Step 26

Tighten and torque the rod end nut at the pitman arm to 40 ft. lbs. with a 21mm socket.

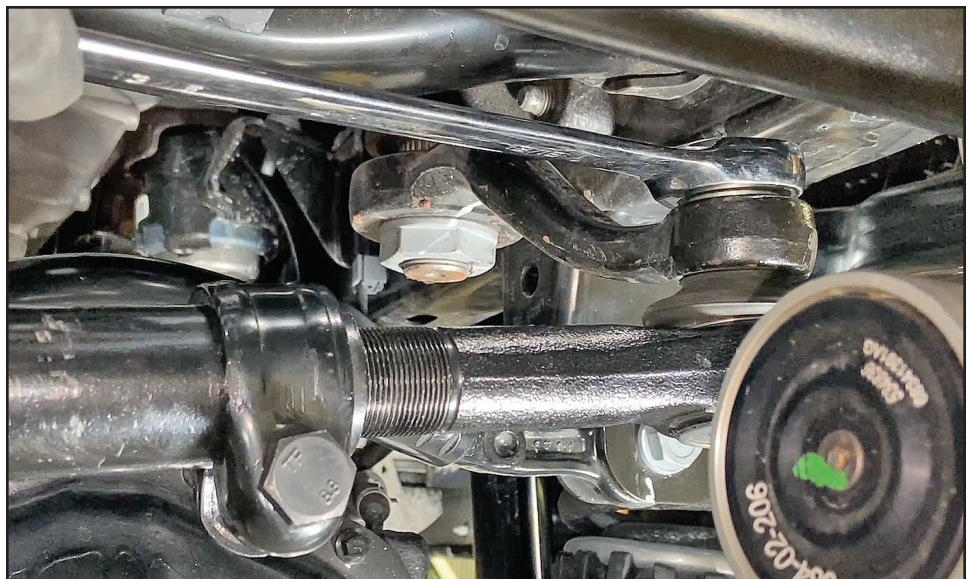

### Step 27

Install a cotter pin thru the hole in all 4 tie rod ends and bend over with your needle nose pliers.

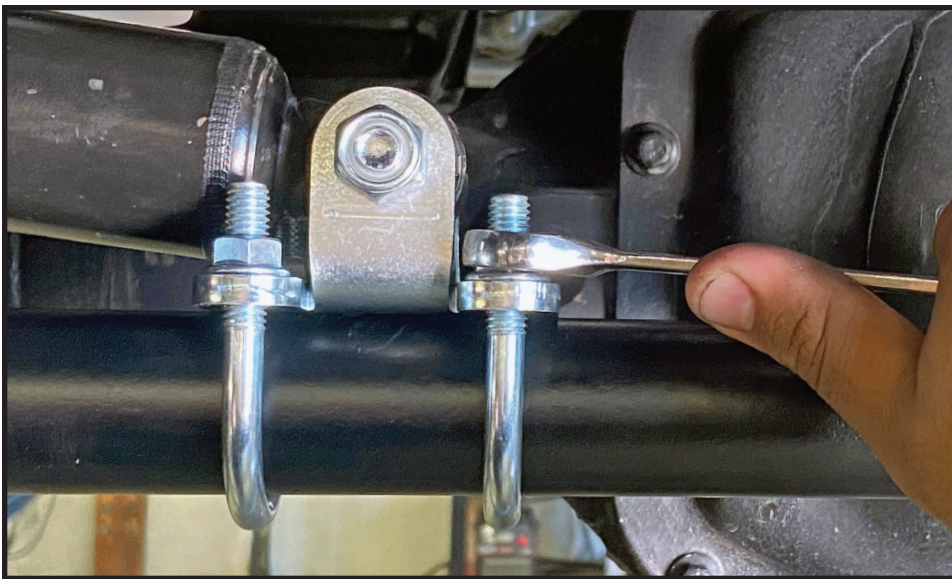

### Step 28

Next we'll install the the new steering stabilizer shock mounting bracket onto the tie rod tube. Simply put the u-bolts around the tie rod, drop the bracket onto them, install the nuts and snug them up for now. Fit the end of the shock into the bracket and install the new bolt from the back side of the bracket (nut on the front). Adjust the location of the bracket to attain proper shock stroke per the Tech Tip below. Once proper adjustment is achieved, tighten the and torque the u-bolt nuts to 25 ft. lbs. with a 9/16" socket to secure the bracket to the tie rod, and then torque the bolt attaching the shock to the bracket to 60 ft. lbs. with a 19mm wrench and socket.



## TECH TIP



### Stabilizer Shock Length Adjustment

With the new steering stabilizer shock bracket installed onto the tie rod, but not tightened down, affix the end of the shock to the bracket. To adjust the shock properly, turn the wheels all the way to the right, to the lock, and hold them there. Completely compress the stabilizer shock, pull it back out 1/8" and then clamp the stabilizer shock bracket down onto the tie rod. Lastly, torque the shock to the bracket.

### Step 29

Obviously, after the install of this kit, you'll want to take your vehicle immediately to an alignment shop. However, you can double check how close you are by measuring from tire bulge to tire bulge on the tires (on the front of the tires, and then to the back of the tires).

For initial setting, so that you can safely drive to an alignment shop, you should try to get these dimensions to be equal.

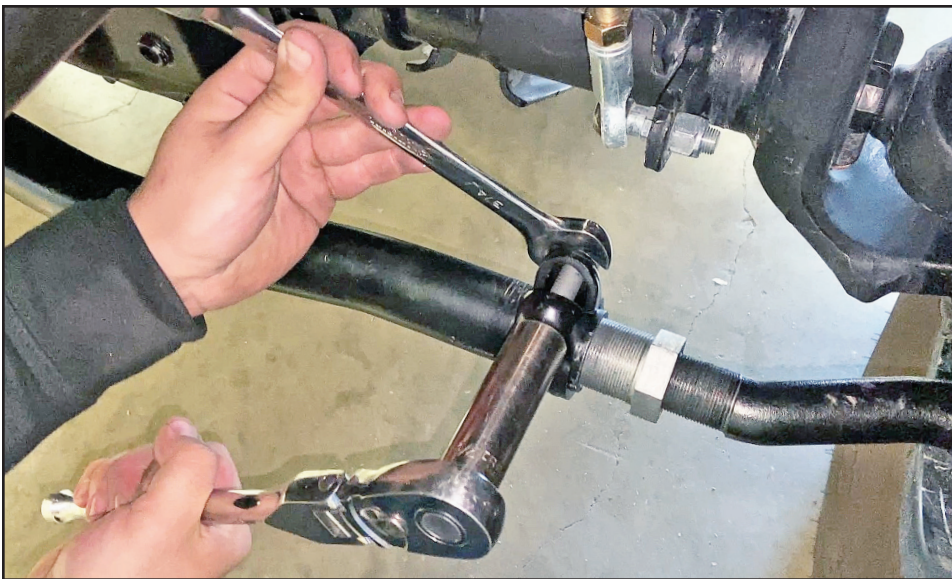

### Step 30

Final adjustments can be made by adjusting the double adjuster with a 1 1/2" wrench.

Once you are happy with the tie rod settings, go ahead and lock the tie rod adjuster clamp down with a 18mm socket and a 19mm wrench and torque to 35 ft. lbs.

### Step 31

Don't forget to tighten the jam nut at the passenger's side wheel!

Lastly, go back and grease all 4 of the rod end grease zerk fittings with a regular, non-synthetic high moly lube grease.



### Step 32

You are now to a place where you can safely move the vehicle. You'll now want to check that your steering wheel is centered when the wheels are straight. This is critical to several electronic functions of new vehicles.



### Step 33

If you find the steering wheel to be off, set the tires straight and, with the steering wheel unlocked, use the adjuster at the pitman arm and adjust it until the steering wheel is straight. You will most likely have to adjust, move the vehicle around, recheck and readjust. Again, all of this is initial settings. Your alignment shop will get everything perfect for you. Once you are satisfied with a close initial setting, tighten the 2 adjuster bolts with an 19mm socket and a 19mm wrench and torque to 35 ft. lbs.

