

Installation Manual



AIR SUSPENSION KIT

Ford F-250 / F-350 / F-450 Super Duty (2WD/4WD) SRW & DRW**

**Will not fit Cab & Chassis models*

Use the most advanced air springs on the market to eliminate your vehicle's sag, sway and bottoming out. This heavy duty air suspension kit levels your truck's stance while providing added support for an overall smooth and safe ride.

** See application guide for proper fitment.*

L6633_REV2_07.09.2025

Thank you and congratulations on the purchase of an Air Suspension kit. Please read the entire manual prior to starting the installation to ensure you can complete it once started.

IMPORTANT

An air suspension kit will not increase the GVWR (*Gross Vehicle Weight Rating*), as the GVWR is determined by the vehicle manufacturer. **Do not exceed the maximum capacity listed by the vehicle manufacturer.**

For safe and proper operation of the vehicle, never exceed the maximum listed PSI in the air springs (*found on the final page of the manual*). Staying under the pressure limit will ensure maximum air spring life. **Failure in doing so may result in damage to your vehicle and/or a void warranty.**

SAFETY WARNINGS!

! Please read and abide the instructions found in this manual, paying close attention to the helpful, cautionary or dangerous warning icons highlighting important safety recommendations and maintenance suggestions throughout this manual.

HELPFUL INSTALL TIP
 Additional information that could potentially make the job a little easier.

PLEASE USE CAUTION
 Unsafe practices could result in damage to you or your vehicle, or others.

DANGER WARNING
 Hazards which could result in severe personal injury or death.

! Serious personal injury or death may result from an air spring failure or accident due to improper installation or air spring pressure operation or maintenance.

! Inflating an unsecured air spring is dangerous. If it bursts, it could be hurled into the air with explosive force resulting in serious personal injury or death. Never inflate an air spring unless it is secured to the vehicle.

! Removing and replacing air springs can be dangerous. This is only a job for a qualified service professional. Never perform air spring service procedures without proper training, tools, and equipment.

BEFORE STARTING THE INSTALLATION

- !** Ensure the application information is correct for the make, model and year of the vehicle you are installing the kit on.
- !** Some vehicles are equipped with a rear wheel brake proportioning valve. Check with the manufacturer before installing the air spring kit, as it may affect braking performance.
- !** This kit contains push-to-connect fittings; using scissors or wire cutters to cut the nylon air line will distort the line and cause the connection to leak. The air line must be cut off squarely with the hose cutter provided in this kit, or a sharp utility knife. **Failure to do so may void the warranty.**
- !** It is recommended to use additional thread sealant or Teflon tape on fittings during the installation for a proper seal.
- !** Always ensure the bolts are not over-torqued; especially when a torque value is provided, as it can lead to premature failure and **may void the warranty.**
- +** It is recommended to use a good quality anti-seize on all fasteners. This will reduce the chance of corrosion on the fasteners and will help facilitate removal, if required at a later date.

! **WARNING:** This product can expose you to the chemical Hexavalent Chromate, which is known to the State of California to cause cancer and birth defects or other reproductive harm. **For more information go to www.P65Warnings.ca.gov**

KIT CONTENTS

Please confirm the items below are provided in your kit before starting the installation.

HEAVY DUTY KITS		QTY	PART #
A¹	Double Convoluted Spring	2	HP10000
C¹	Roll Plate	4	HP10054
D¹	90° Swivel Fitting, 1/4" Hose to 1/4" NPT	2	HP1100

HEAVY DUTY JOUNCE BUMPER KITS		QTY	PART #
B¹	Double Convoluted Spring w/ Jounce Bumper	2	HP10000J
C¹	Roll Plate	4	HP10054
D¹	90° Swivel Fitting, 1/4" Hose to 1/4" NPT	2	HP1100

XTREME DUTY KITS		QTY	PART #
A²	Double Convoluted Spring	2	HP10438
C²	Roll Plate	4	HP10069
D²	90° Swivel Fitting, 1/4" Hose to 3/8" NPT	2	HP1245

XTREME DUTY JOUNCE BUMPER KITS		QTY	PART #
B²	Double Convoluted Spring w/ Jounce Bumper	2	HP10438J
C²	Roll Plate	4	HP10069
D²	90° Swivel Fitting, 1/4" Hose to 3/8" NPT	2	HP1245

SHARED KIT CONTENTS		QTY	PART #
E	Spacer, Lower Bracket	4	HP1749
F	Bracket, Upper Bag	2	HP2040
G	Bracket, Upper Frame	2	HP2041
H	Bracket, Lower Axle	2	HP2110
I	Bracket, Lower Bag	2	HP2111
J	Strap, Axle	2	HP0009
K	U-Bolt, 3/8" - 16 x 7"x 5.5" Square	2	HP1486
L	Bolt, 3/8" - 16 x 1" Square Neck Plow	4	HP1734
M	Bolt, 3/8" - 16 x 1.5" Hex Head	8	HP1646
N	Bolt, 3/8" - 16 x 4" Carriage	4	HP1728
O	Bolt, 3/8" - 24 x 7/8" Hex Head	4	HP1002
P	Bolt, 3/8" - 24 x 3/4" Countersunk	4	HP1008
Q	Washer, 3/8" Flat	12	C18006
R	Washer, 3/8" Split Lock	4	C18007
S	Nut, 3/8" - 16 Nylon Lock Flange	20	HP1975
T	Worm Gear Ring Clamp	2	HP1001
U	Worm Gear Ring Clamp	2	HP1377
V	Heat Shield	2	HP0012

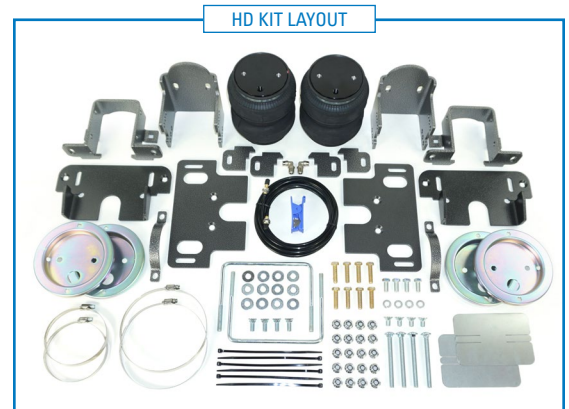
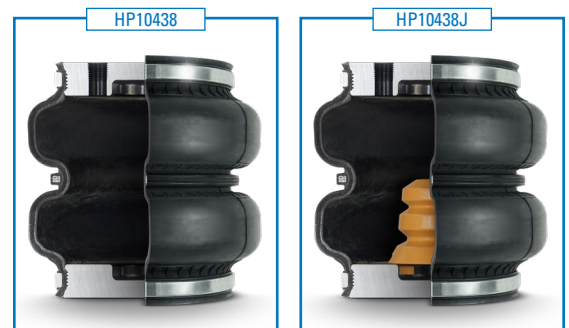
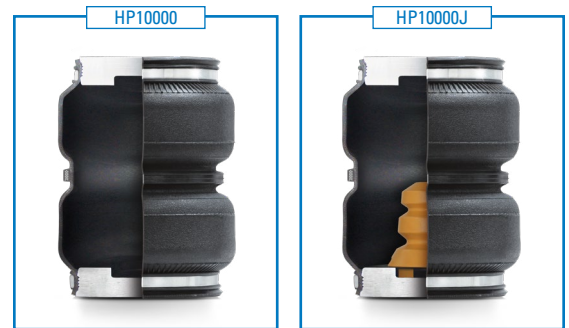

REQUIRED TOOLS

- Hoist or Floor Jack
- Safety Glasses
- Pipe Thread Sealant
- Standard Combination Wrenches
- 7/32" Hex Allen Wrench
- Metric & Standard Sockets
- Hose Cutter (included) or Sharp Utility Knife
- Spray Bottle with Dish Soap/Water
- Air Compressor/Compressed Air Source (to test/fill air springs)
- Heavy Duty Drill
- 3/8 & 5/16 drill bits (very sharp)
- 3/8 Nut Driver
- Safety Stands
- Torque Wrench
- Ratchet

KIT EXPLOSION DIAGRAM

DRIVER SIDE ASSEMBLY SHOWN (Passenger side assembly is mirrored)

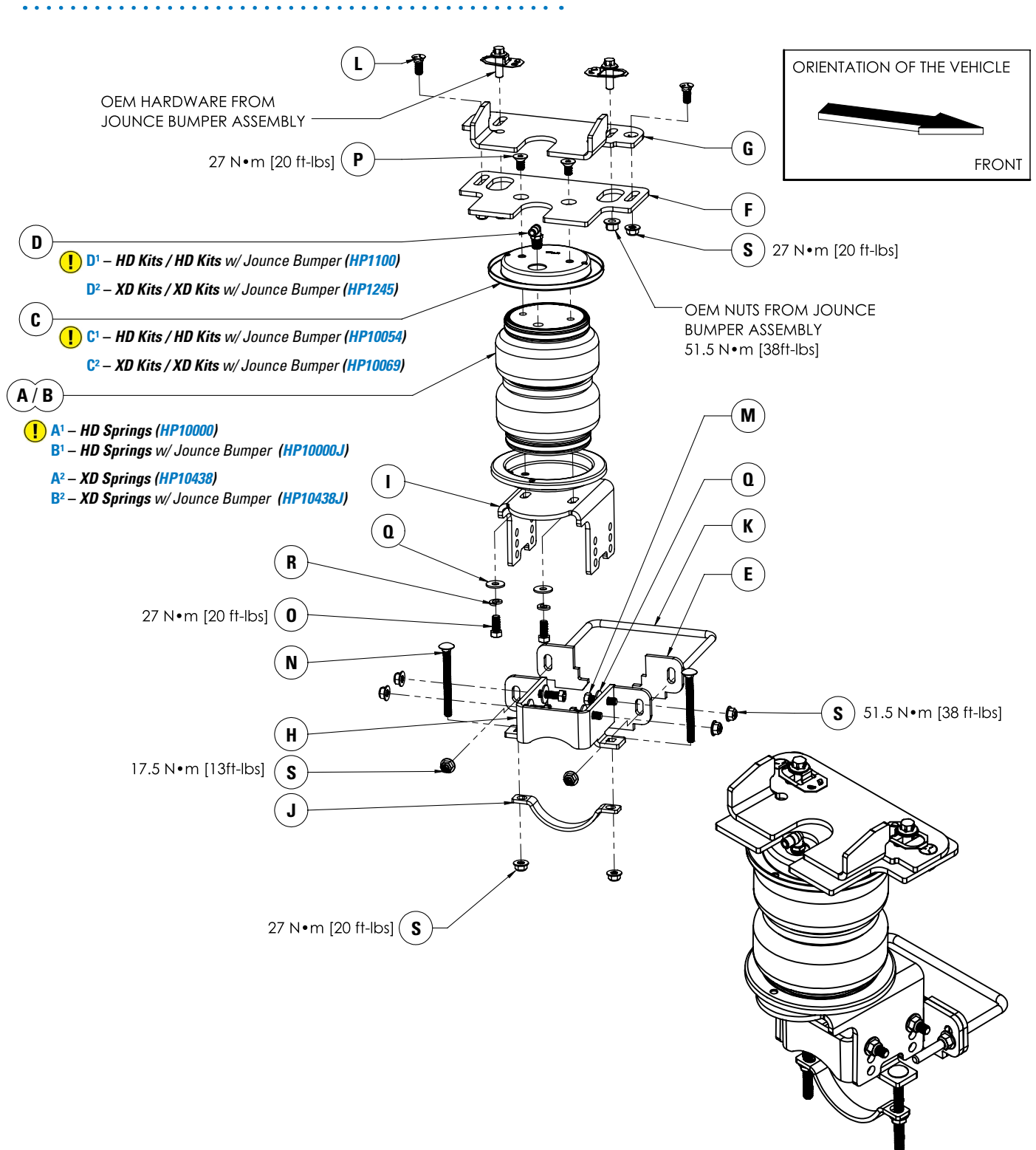

INSTALLATION INSTRUCTIONS

1 MEASURE STOCK RIDE HEIGHT & CLEARANCE

Park the vehicle on a level surface and remove any unnecessary weight from the vehicle to attain a "Normal Ride Height".

Using a measuring tape, measure the distance between the center of the wheel hub and the bottom of the fender well (see Figure 1A for reference) this will give you your stock Normal Ride Height.

Note the ride height for all four tires.

Check the clearance between the outside of the frame and the inside of the rear tires (as shown in red in Figure 1B), a minimum of 5" is required for adequate air spring clearance.

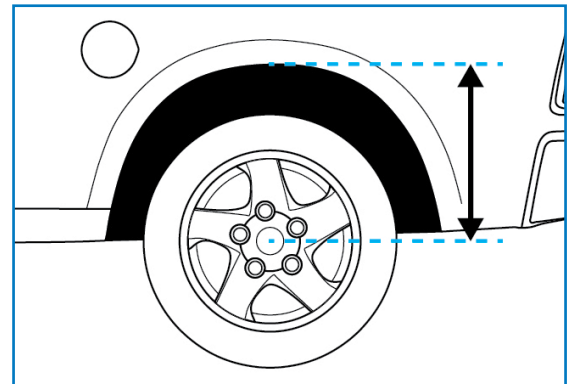

1A

2 REMOVE REAR WHEELS

+ PLEASE NOTE: This step is optional for this installation but will make the install easier to complete.

Place wheel chocks in front of and behind both front wheels.

Raise the rear of the truck high enough to remove both wheels and attain a comfortable working height.

Place two jack stands under rear axle (as shown in Figure 1B).

Lower the vehicle until the axle is supported by the jack stands.

Remove rear wheels.

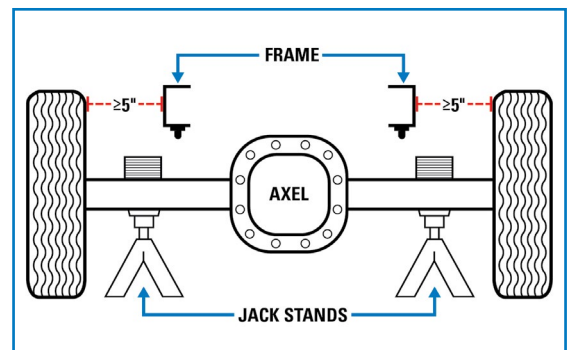

1B

3 REMOVE THE JOUNCE BUMPER

Unbolt and remove the jounce bumper assembly from under the frame on both sides of the vehicle (as shown in Figure 3).

! **Do not remove the OEM bolts and retainer clips from the frame of the vehicle.**

Do not discard any OEM components as they will be reused later in the installation.

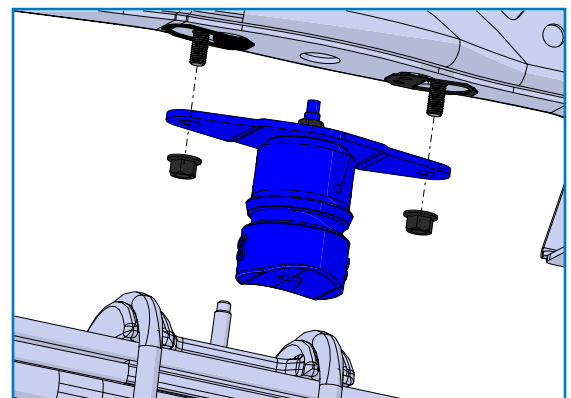

3

4 PRE-ASSEMBLE UPPER AIR SPRING

Set a roll plate on top of the air spring, lining up all 3 holes in the roll plate to the 3 holes in the top of the air spring.

Install the NPT fitting into the largest port on the top of the air spring.

Tighten the fitting finger tight plus an additional 1.5 turns.

+ *The use of Teflon tape or thread sealant is recommended.*

Place the Upper Bag Bracket on top of the air spring assembly, align all two remaining holes, and insert two 3/8" - 24 x 3/4" countersunk bolts.

Torque countersunk bolts to 27 N•m (20 ft-lbs).

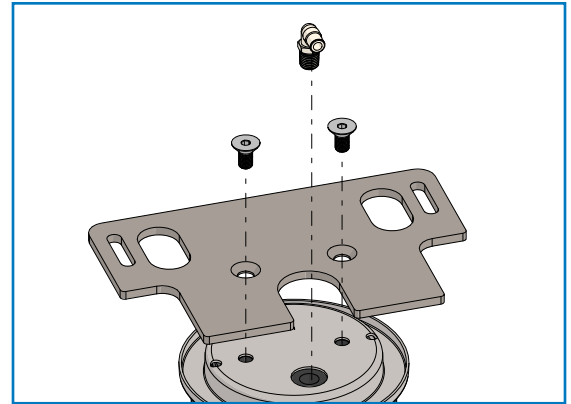

4

5 TEST FIT LOWER BRACKET

Place both halves of the Lower Bracket on the axle, over top of the jounce bumper strike plate.

Determine which holes allow the Lower Bracket to be in its "shortest" configuration.

+ *Note or mark these holes for later use during assembly in Step 7.*

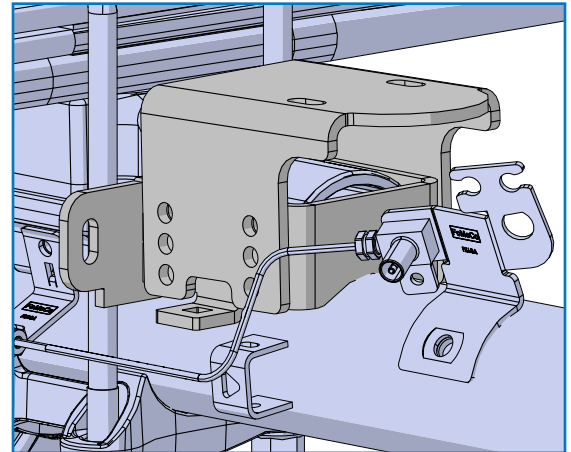

5

6 PRE ASSEMBLE LOWER BRACKET ON AIR SPRING

Place a roll plate on the bottom of the air spring.

Place the Lower Bracket on top of the roll plate. (See Figure 6 for correct bracket assembly orientation with the previously installed Upper Bracket).

Secure the assembly with the two 3/8" - 24 x 7/8" hex bolts, two 3/8" flat washers, and two 3/8" split lock washers.

Tighten but **do not torque the bolts at this step**. Leave the nuts slightly loose to allow for adjustment later in the installation.



6

7 INSTALL LOWER HALF OF BRACKET

Install the lower section of bracket on the air spring assembly, using the holes previously determined from the test fitment in Step 5.

Secure the assembly with four 3/8" -16 x 1.5" hex head grade 8 bolts, four 3/8" flat washers on the hex head side of the bolt, and four nylon locking flange nuts on the outside of the assembly (as shown in Figure 7).

Torque to 51.5 N•m (38 ft-lbs)

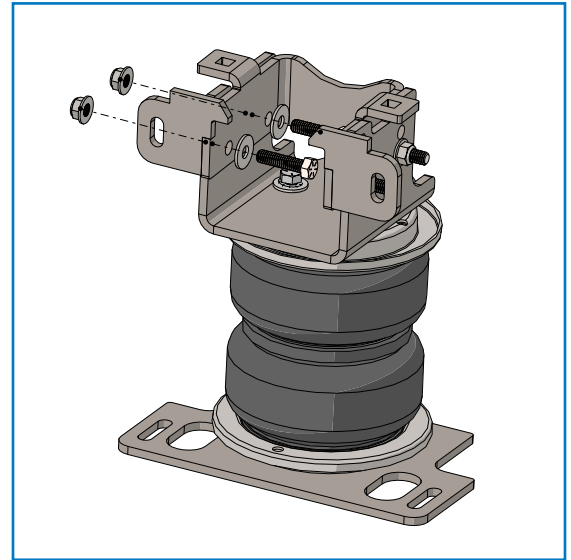

7

8 INSTALL UPPER FRAME BRACKET

Place two 3/8" - 16 x 1" plow bolts into the countersunk holes in the Upper Frame Bracket (shown in Figure 8 with black arrows).

Place the Upper Frame Bracket onto the frame reusing the OEM bolts and nuts previously removed from the jounce bumper assembly in Step 3.

+ *The bent ears of the bracket should be in contact with the frame.*

Torque the OEM fasteners to 51.5 N•m [38 ft-lbs].

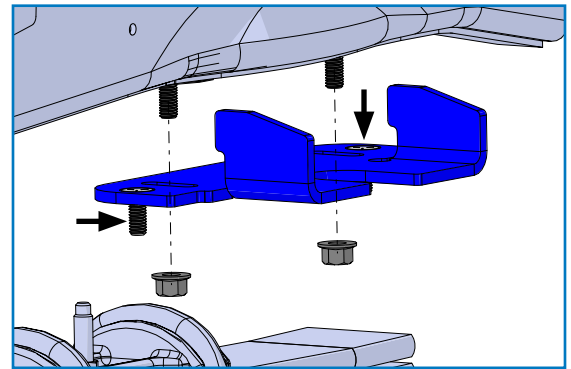

8

9 PLACE PRE-ASSEMBLED AIR SPRING ON AXLE

Maneuver the pre-assembled air spring assembly onto the axle of the vehicle (as shown in Figure 9).

+ *It may be necessary to compress the air spring to allow the assembly to fit.*

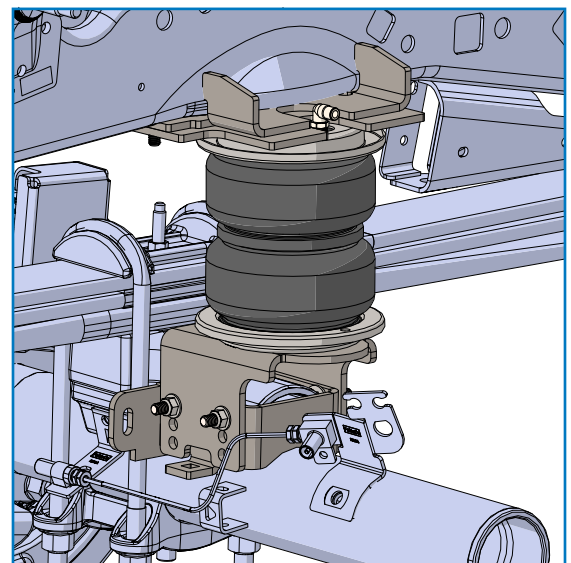

9

10 BOLT UPPER AIR SPRING BRACKET TO FRAME BRACKET

Maneuver the air spring assembly until the hardware in the Upper Frame Bracket aligns with the slots in the Upper Bag Bracket.

Loosely secure the air spring assembly to the vehicle frame by installing nylon lock flange nuts to the plow bolts (previously installed in Step 8).

Using two Nylon locking flange nuts, bolt the top Air Spring Bracket to the Frame Bracket.

Tighten but **do not torque the bolts at this step**. Leave the nuts slightly loose to allow for adjustment later in the installation.

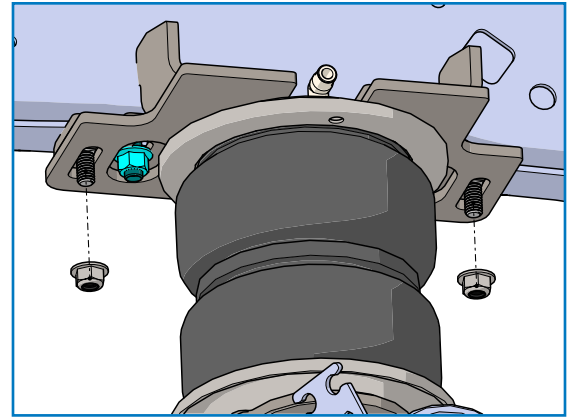

10

11 BOLT LOWER BRACKET TO AXEL AND LEAF SPRING

Place the U-bolt around the leaf spring pack, and through the slots on the Lower Bracket.

Secure with two nylon locking flange nuts but leave slightly loose to allow for adjustment later in the installation.

Use two 3/8" -16 x 4" carriage bolts, an axle strap, and two nylon locking flange nuts and secure the bottom of the Lower Bracket to the axle (as shown in Figure 11A).

Adjust the bracketry and air spring to be as tight as possible to the leaf pack, while still having clearance.

⚠ PLEASE NOTE: *The Lower Bracket should contact the leaf spring and OEM U-bolt.*

If it does not: remove air spring kit U-bolt, and insert the provided Spacers (HP1749) behind Lower Bracket (as shown in Figure 11B) to ensure full contact.

Reinstall U-bolt through both Spacers and Lower Bracket.

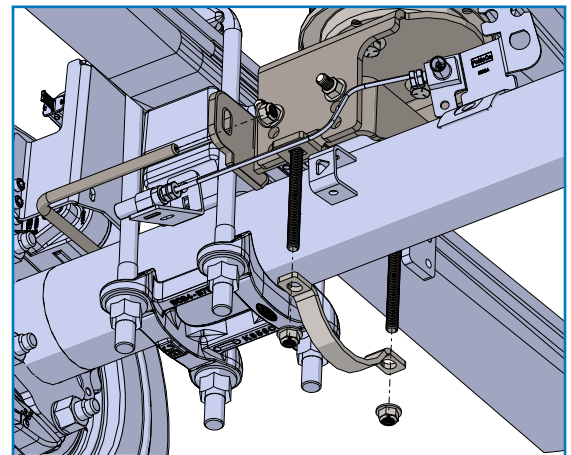

11A

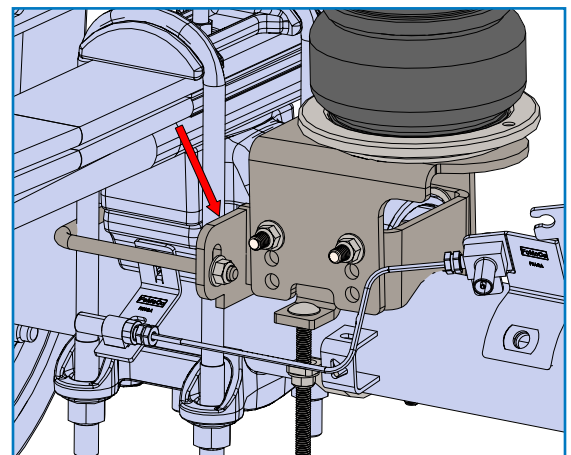

11B

12 TIGHTEN ALL FASTENERS

With the assembly secured to the frame of the vehicle, perform any manual adjustments to the Lower Bracket required to ensure the air spring is aligned vertically (see Figure 12 for proper air spring alignment).

Torque the two U-bolt nuts to 17.5 N•m [13 ft-lbs]

Torque the two axle strap nuts to 27 N•m [20 ft-lbs]

Torque the two lower air spring bolts to 27 N•m [20 ft-lbs]

Torque the upper air spring frame nuts to 27 N•m [20 ft-lbs]

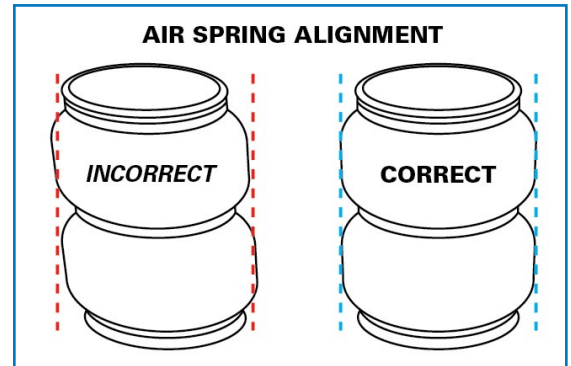

12

REPEAT STEPS 3-12 on the other side of the vehicle

13 INSTALL HEAT SHIELD

On the passenger side of the vehicle, the exhaust pipe bends around the axle close to the air spring assembly. Two heat shields are supplied in this kit to provide increased protection from potential heat that can occur.

Bend the tabs on the heat shields so the required ½" of dead space exists between the heat shield and exhaust when attached (as shown in Figure 13A).

Attach the heat shields to the exhaust pipe using the provided worm gear ring clamps (in the approximate locations shown in Figure 13B).

⊕ *Each clamp holds a tab against the exhaust pipe.*

Installation continues on the following page.

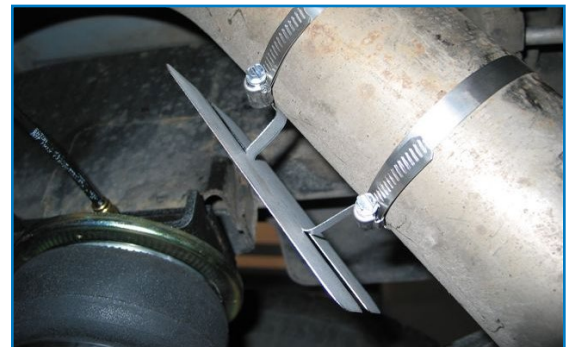

13A

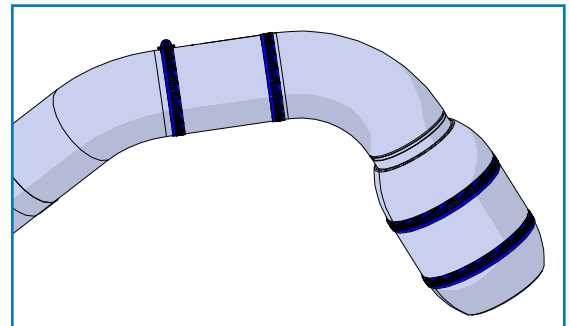

13B

INSTALL AIR LINE

Two fill valves are provided in this kit. The most common place to install them is in place of the license plate fasteners. Alternatively, two 5/16" holes can be drilled in a location of your choosing.

Cut the air line assembly into two equal lengths with the hose cutter provided in this kit or a sharp utility knife.

! PLEASE NOTE: *This kit contains push-to-connect fittings; using scissors or wire cutters to cut the nylon air line will distort the line and cause the connection to leak. The air line must be cut off squarely with a hose cutter or a sharp utility knife.*

Install one air line at a time starting at the fill valve location. Place a 5/16" nut on the air valve. Leave enough of the inflation valve in front of the nut to extend through the hole, install a flat washer, and 5/16" nut and cap (reference Figure A for assembly). There should be enough valve exposed after installation – approximately 1/2" – to easily apply a pressure gauge or an air chuck.

Route the air line back to the NPT fitting on the air spring, then cut the hose to length. Moisten the end of the air line prior to inserting it into the fitting and push it in until it stops.

Repeat with the other fill valve.

Secure the air lines using the provided tie-straps, away from any moving items and heat sources.

CHECK SYSTEM FOR LEAKS

Inflate both air springs to 90 psi (60 psi for in-coil bags), then use a mixture of dish soap and water on all air line connections to detect any air leaks. Large, expanding bubbles indicate a leak (as shown in Figure B).

Repair as necessary and retest.

Inflate air springs to a predetermined value and on following day recheck pressure. If one or both of air springs have lost pressure, an air leak is present.

! Leak must be repaired, and then retested until no leaks exist.

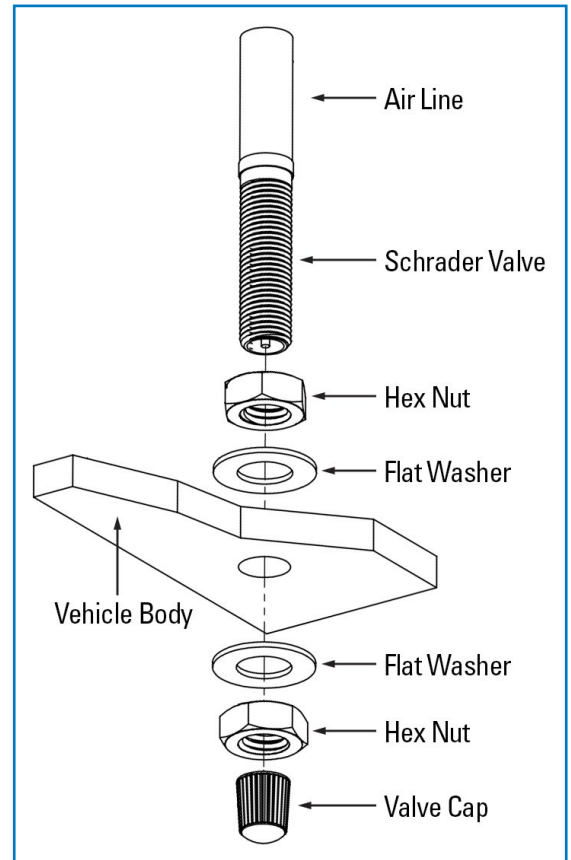

A

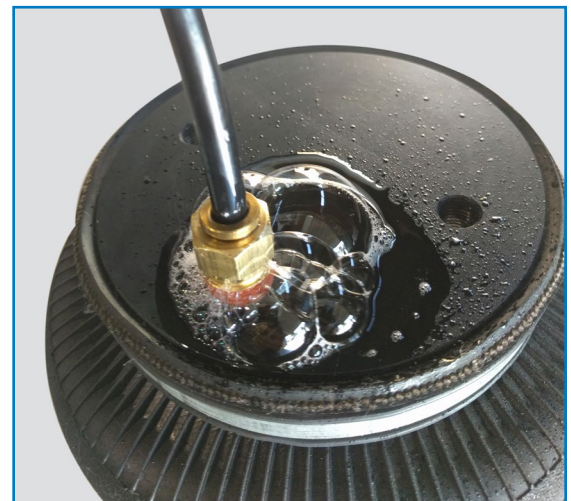

*Air Spring & NPT Air Fitting may differ between kits

B

CONGRATULATIONS! You have completed the install

After Installation continues on the following page.

Thank you again, and congratulations on the installation of your Air Suspension kit.

AFTER COMPLETING THE INSTALLATION

- The air spring must have clearance between itself and the surrounding components to prevent any contact when spring is inflated or compressed. Trimming off excess bolt length may also be required to ensure no contact with the spring or other suspension components can be made once installed.
- If removed, re-install the wheels and torque fasteners to the manufacturer’s specifications. Re-torque all fasteners after the first 500 miles of driving.

OPERATING YOUR VEHICLE WITH AIR SUSPENSION

Air springs have minimum and maximum recommended pressure requirements:

PART #	SPRING STYLE	SPRING TYPE	MIN PSI	MAX PSI
HP10687	In-Coil	STANDARD DUTY	5 PSI	50 PSI
HP10189		STANDARD DUTY	5 PSI	70 PSI
HP10560		STANDARD DUTY		
HP10001	Sleeve Style	STANDARD DUTY	10 PSI	100 PSI
HP10173		STANDARD DUTY		
HP10199		STANDARD DUTY		
HP10083	Single Convoluted	HEAVY DUTY	5 PSI	100 PSI
HP10083J		HEAVY DUTY with JOUNCE BUMPER	0 PSI* / 5 PSI	100 PSI
HP10000	Double Convoluted	HEAVY DUTY	5 PSI	100 PSI
HP10000J		HEAVY DUTY with JOUNCE BUMPER	0 PSI* / 5 PSI	100 PSI
HP10068	Large Double Convoluted	HEAVY DUTY	5 PSI	100 PSI
HP10438	Double Convoluted	EXTREME DUTY	5 PSI	100 PSI
HP10438J		EXTREME DUTY with JOUNCE BUMPER	0 PSI* / 5 PSI	100 PSI

**Springs with a jounce bumper can be run at zero PSI when vehicle is unloaded only*

For safe and proper operation, never operate the vehicle over the maximum listed PSI in the air springs. Staying under the pressure limit will ensure maximum air spring life. **Failure in doing so may result in damage to your vehicle and/or a void warranty.**

! *It is recommended to check the air pressure in your air springs daily for first couple of days to ensure a leak has not developed.*

Air springs are designed to maintain the vehicle’s stock ride height with a load. Do not use the air springs as a means to lift vehicle with no load. This will result in a harsh ride.

SERVICING YOUR VEHICLE WITH AIR SUSPENSION

When lifting the vehicle with a floor jack or hoist on the frame, never allow the air spring to limit the travel of the axle. Try to always jack the vehicle on the axle. Suspending the axle with the air spring limiting the axle travel will damage the air spring and void the air spring warranty.

WARRANTY

See additional warranty included with this kit for details.