

Installation Manual

PACPRO



HP10305 KIT

*2010-2017 Dodge RAM with 1"-16 UN Oil
Filter Threads*

800.663.0096
www.pacbrake.com



KIT CONTENT

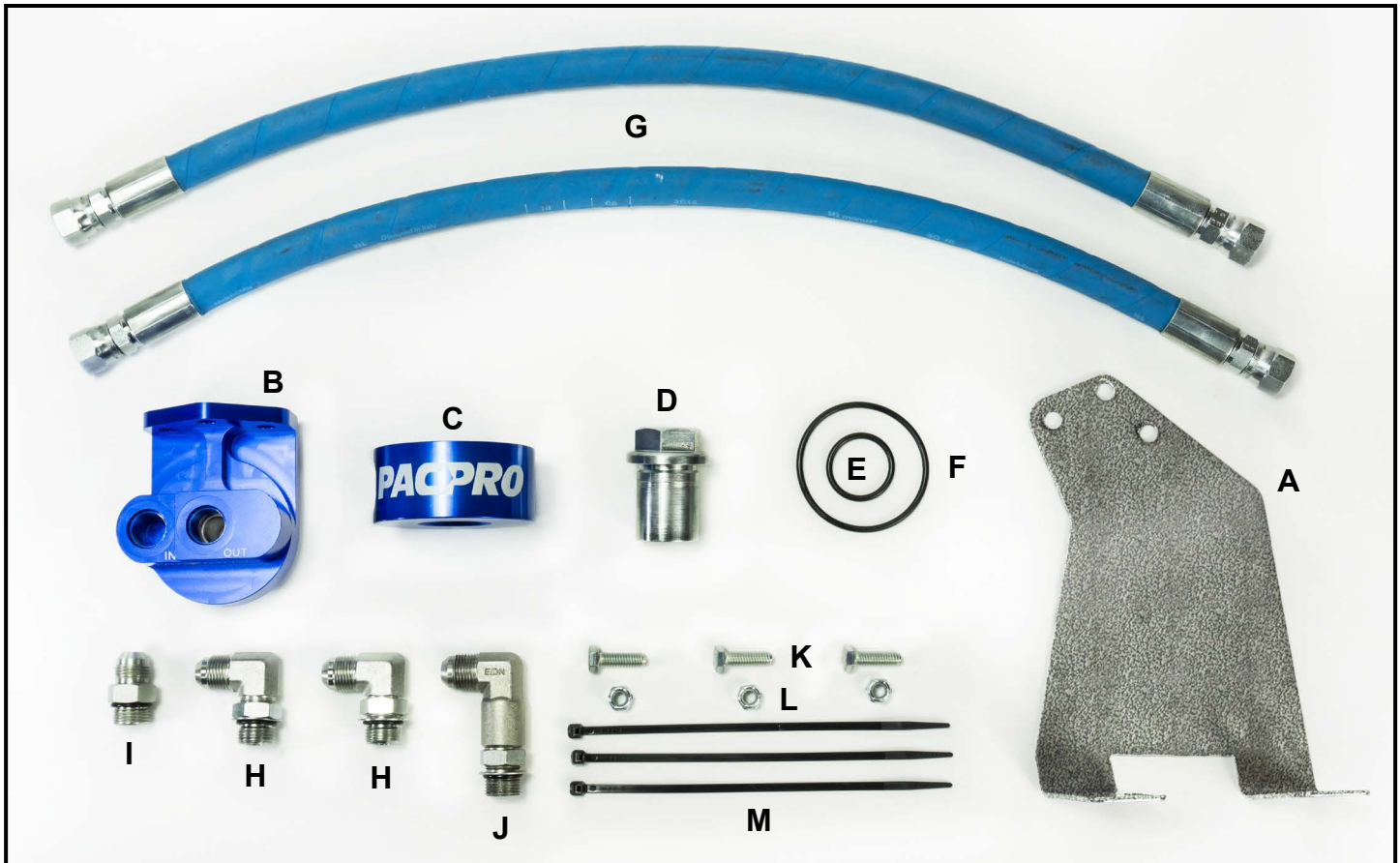

KIT CONTENTS

A	Oil Filter Relocation Bracket	1
B	Remote Filter Head	1
C	Replacement Filter Head	1
D	Retaining Nut	1
E	O-Ring (Small)	1
F	O-Ring (Large)	1
G	Hydraulic Hose	2
H	90° Hydraulic Fitting	2
I	Straight Hydraulic Fitting	1
J	Extended 90° Hydraulic Fitting	1
K	5/16"-18 x 1" Hex Head Cap Screw	3
L	5/16" 18 Nyloc Nut	3
M	Tie Straps	3

Make sure all the items shown in the photo are provided in your kit before starting the installation.

Thank you and congratulations on your purchase of a remote oil filtration relocation kit.

HP10305 - 2010-2017 Dodge RAM with a Cummins 6.7L diesel engine with 1" x 16 UN Oil Port.

Before starting, please read this entire manual to ensure you have a good understanding of the installation.

- 1 Remove the existing oil filter and recycle.



1

- 2 Locate the straight and 90° hydraulic fittings provided in the kit. Install them into the replacement filter head as shown in figure 2. Tighten the lock nut on both fittings to 40 ft-lbs (54 N•m).

NOTE: Ensure the 90° fitting is pointing downwards after tightening.

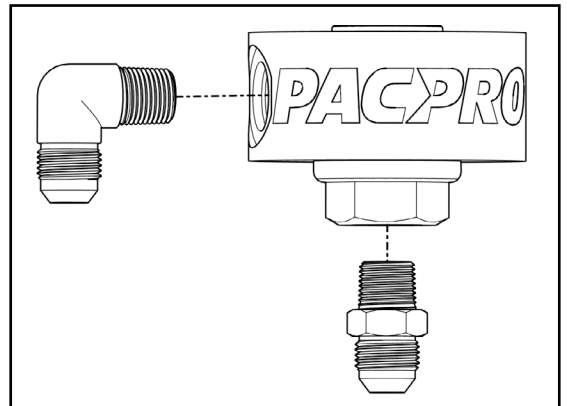

2

- 3 Install both seals onto the replacement filter head assembly as shown in figure 3. Put a light coat of clean engine oil on both seals and loosely install the assembly into the engine by turning the filter head retaining nut.

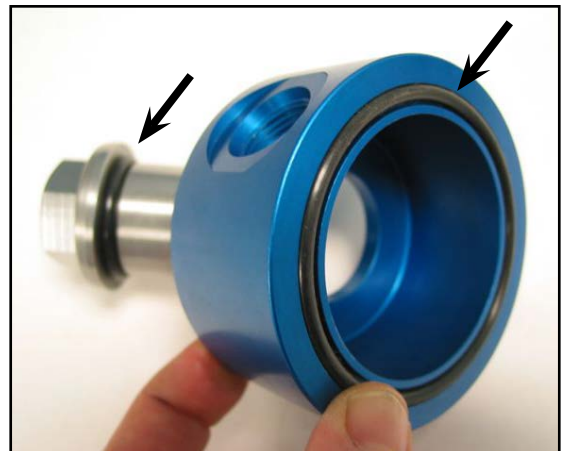

3

- 4 Rotate the replacement filter head assembly to attain maximum clearance for hose routing. Tighten the filter head retaining nut as you would for a new filter installation.

- 5** Using the $\frac{5}{16}$ " fasteners provided, secure the remote filter head to the mounting bracket as shown in Figure 5.
Torque the screws to 25 ft-lbs (34 N•m).

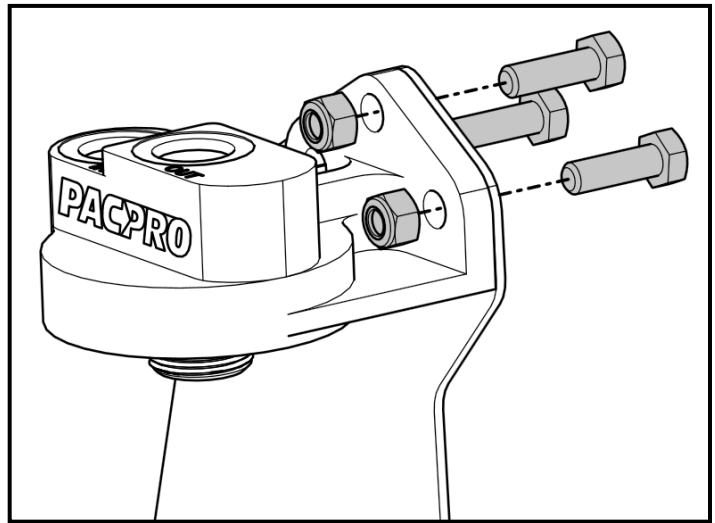

5

- 6** Locate the 90° hydraulic fittings and install them into the remote filter head as shown in figure 6.
Do not tighten the fittings yet to allow for adjustment.

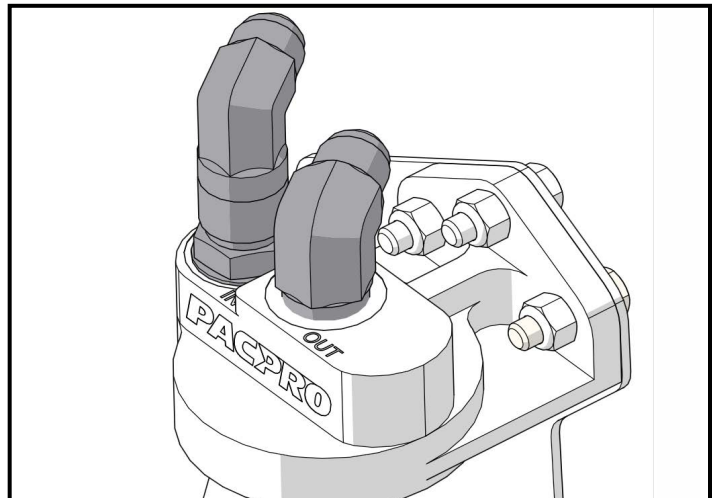

6

- 7** Locate the two cap screws holding the sway bar in place on the passenger side. Remove the screws, install the filter mounting bracket, and loosely reinstall the cap screws.

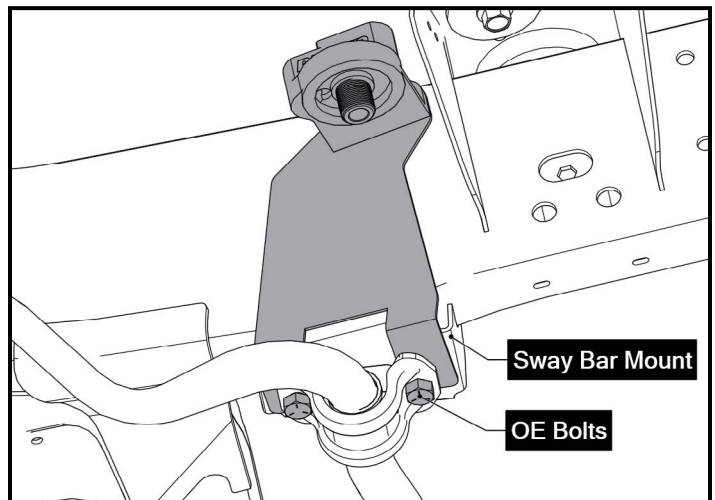

7

- 8** Rotate the 90° hydraulic fittings to attain maximum clearance for hose routing. Use a marker to mark the orientation of the hydraulic fittings.

NOTE: Ensure that the fittings on the hoses have enough clearance to attach onto the fittings on the remote filter head.

- 9 Remove the filter mounting bracket out from under the vehicle and tighten the lock nut on both of the hydraulic fittings on the remote filter head to 40 ft-lbs (54 N•m).
- 10 Locate the two hydraulic hoses provided in the kit and install one end of each hose onto the 90° fittings on the remote filter head. Tighten both hose end fittings to 40 ft-lbs (54 N•m).
- 11 With the hoses still attached to the filter mounting head, roughly route the hoses into the vehicle and reinstall the filter mounting bracket into the vehicle. Torque the sway bar cap screws to 45 ft-lbs (61 N•m)
- 12 Route the hoses from the remote filter head to the fittings on the replacement filter head. Connect the hose attached to the **center** fitting of the remote filter head to the **center** fitting on the replacement filter head. Connect the hose attached to the **outside** fitting on the remote filter head to the **outside** fitting on the replacement filter head. Tighten both fittings.

NOTE: Use the supplied tie straps to secure the hydraulic lines away from heat sources and moving parts.

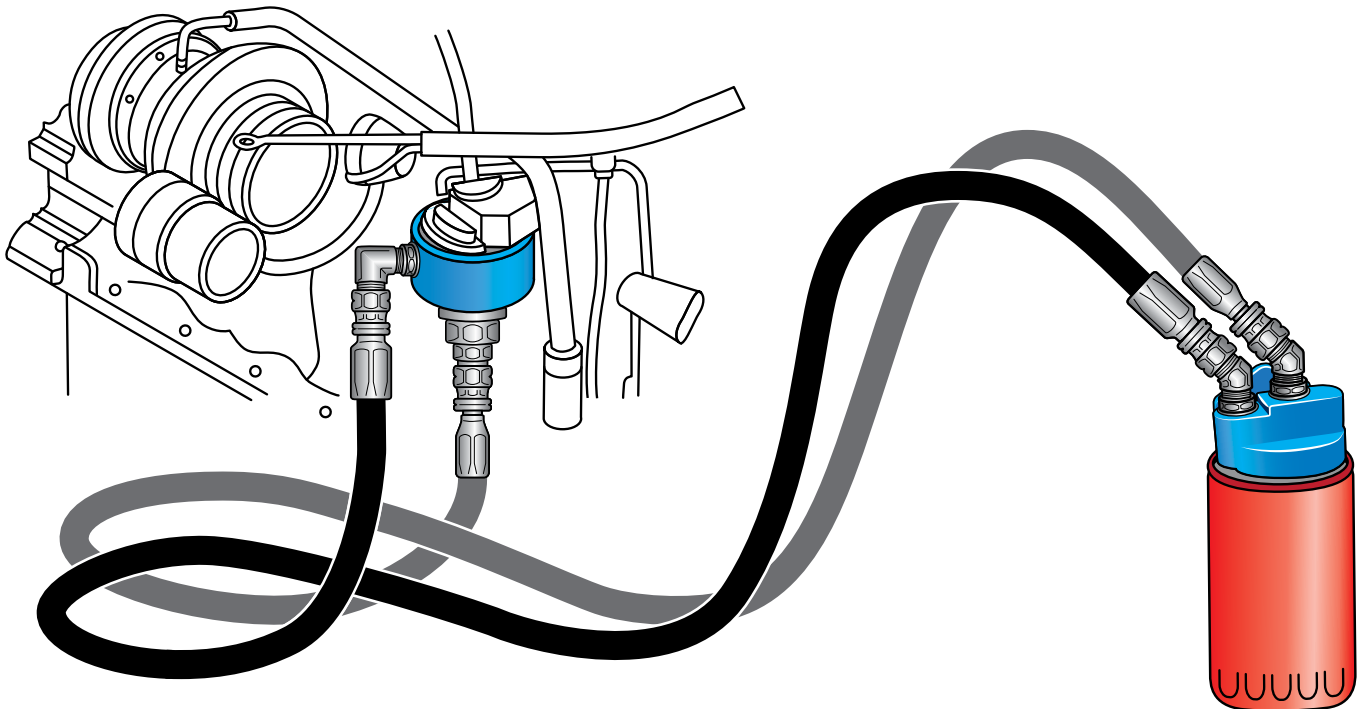

- 13 Install a new oil filter into the remote filter head. It is recommended to fill the new oil filter with clean engine oil prior to installation. Double check all the fittings to ensure they are tightened adequately before moving on to the following step.
- 14 Start the vehicle and allow it to idle while watching the oil pressure gauge. Once the engine oil pressure is in the normal range, check the entire system again for oil leaks.

Congratulations! You have completed the installation.