

Installation Manual



10072 KIT

GMC SIERRA: 1500HD 2WD/4WD (Heavy Loads),
2500 (Except 2500HD) 2WD/4WD*

CHEVROLET SILVERADO: 1500HD 2WD/4WD (Heavy Loads),
2500 (Except 2500HD) 2WD/4WD*

Use the most advanced air springs on the market to eliminate your vehicle's sag, sway and bottoming out. This heavy duty air suspension kit levels your truck's stance while providing added support for an overall smooth and safe ride.

* See application guide for proper fitment.

L5863_REV5_08.21.2020



WARNING: This product can expose you to the chemical Hexavalent Chromate, which is known to the State of California to cause cancer and birth defects or other reproductive harm. *For more information go to www.P65Warnings.ca.gov*

IMPORTANT

This air suspension kit will not increase the GVWR (*Gross Vehicle Weight Rating*), as the GVWR is determined by the vehicle manufacturer. **Do not exceed the maximum capacity listed by the vehicle manufacturer.**

Safety Warning!

Serious personal injury or death may result from an air spring failure or accident due to improper installation or air spring pressure operation or maintenance. Please read and abide the instructions, safety recommendations and maintenance suggestions throughout this manual.

Safety Warning!

Inflating an unsecured air spring is dangerous. If it bursts, it could be hurled into the air with explosive force resulting in serious personal injury or death. Never inflate an air spring unless it is secured to the vehicle.

Safety Warning!

Removing and replacing air springs can be dangerous. This is only a job for a qualified service professional. Never perform air spring service procedures without proper training, tools, and equipment.

.....



KIT CONTENTS

	QTY	PART #
A Air Springs	2	HP10000
B Lower Bracket	2	HP1137
C Upper Frame Bracket	2	HP1140
D 90° Fitting	2	HP1100
E Roll Plate	4	HP10054
F Heat Shield	1	HP0012
G 3/8" Nylock Nut	10	HP1000
H 5/16" Flat Washer	6	C11944
I 3/8" Lock Washer	4	C18007
J 3/8"-24 x 7/8" Bolt	4	HP1002
K 3/8" Flat Washer	16	C653
L 3/8" - 16 x 1" Capscrew	4	C10464
M 3/8"-16 x 3" Carriage Bolt	4	HP1003
N 5/16" Nylock Nut	2	C11943
O 3/8" - 24 x 3/4" Countersink Screw	4	HP1008
P Heat Shield Clamp	2	HP1001
Q Axle Strap	2	HP0074
R 5/8" Clamp	1	HP1006
S 5/16" x 1 Capscrew	3	C11819
T 3/8" x 3/4" Bolt	2	C11571
U M8 x 1:25 Bolt	1	HP1146
V 5/16" Lock Washer	1	C384
W Bracket, Emergency Brake Relocation	1	HP0011
X Bracket, Brake Line Relocation	1	HP1145
Y Upper Bracket Adaptor Plate	2	HP0095
Z 5/16" NC Flange Nut	1	P05654
1 Air Line/Valve Assembly	1	HP1344
2 Tie Straps	6	C11618

KIT CONTENTS

Please make sure all the items shown in the kit layout are provided in your kit before starting the installation.

REQUIRED TOOLS

- Hoist or Floor Jack
- Safety Stands
- Safety Glasses
- Torque Wrench
- Standard Combination Wrenches
- 7/32" Hex Allen Wrench
- 1-1/8" Wrench or Deep Socket
- Ratchet
- Metric & Standard Sockets
- Hose Cutter (included) or Sharp Utility Knife
- Pipe Thread Sealant
- Spray Bottle with Dish Soap/Water
- Air Compressor/Compressed Air Source (to test/fill air springs)

BEFORE STARTING THE INSTALLATION:

1. Ensure the application information is correct for the make, model and year of the vehicle you are installing the kit on.
2. Some vehicles are equipped with a rear wheel brake proportioning valve. Check with the manufacturer before installing the air spring kit, as it may affect braking performance.
3. It is recommended to use a good quality anti-seize on all fasteners. This will reduce the chance of corrosion on the fasteners and will help facilitate removal, if required at a later date.

PLEASE NOTE:

This kit contains push-to-connect fittings; using scissors or wire cutters to cut the nylon airline will distort the line and cause the connection to leak. THE AIRLINE MUST BE CUT OFF SQUARELY WITH THE NYLON HOSE CUTTER PROVIDED IN THIS KIT OR A SHARP UTILITY KNIFE.

1 MEASURE STOCK RIDE HEIGHT

Park the vehicle on a level surface. Remove any unnecessary weight from the vehicle to attain a Normal Ride Height. This is important for correct initial air spring set-up and adjustment.

Using a measuring tape, measure the distance between the center of the wheel hub and the bottom of the fender well (as shown in Figure 1) this will give you your ride height.

Note the ride height for all four corners.

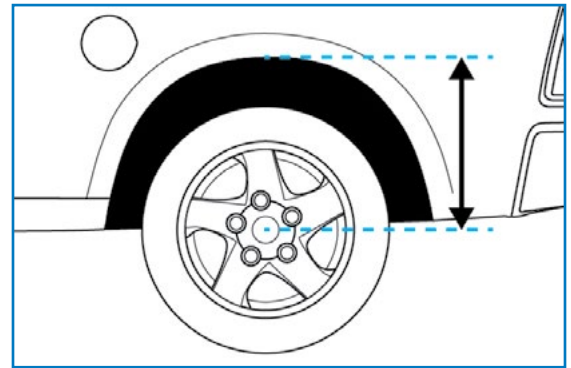

1

2 REMOVE REAR WHEELS

Place wheel chocks in front of and behind both front wheels.

Raise the rear of the truck high enough to remove both wheels and attain a comfortable working height.

Place two jack stands under rear axle (shown in Figure 2).

Lower the vehicle until the axle is supported by the jack stands.

Remove rear wheels.



2

3 REMOVE JOUNCE BUMPER

Remove the jounce bumpers on both sides and discard as it will not be used again in this installation.



3

4 UPPER ROLL PLATE

Place the upper roll plate (with the rounded side towards the air spring) on the top of the air spring (the top being the end with the air inlet port). (See Figure 4 for reference)

Install the supplied 90° air fitting (shown with an arrow) using thread sealant to prevent air leaks.

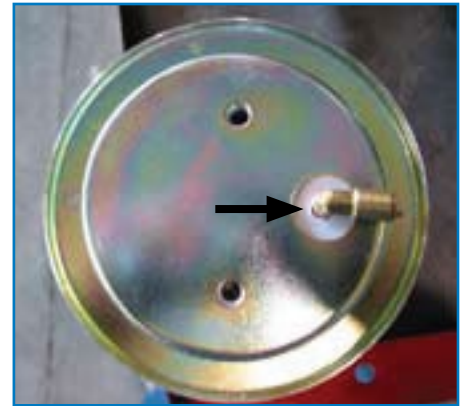

4

5 UPPER BRACKET

Place the upper air spring mounting bracket on top of the air spring and roll plate, as shown in Figure 5. Loosely install the 3/8" x 7/8" NF capscrews with the provided flat and lock washers.

Do not tighten fully at this point as a final adjustment will be necessary once installed on the vehicle



5

6 LOWER BRACKET

2500 Models Only: (3/4 ton trucks) require a 3/8" x 3/4" bolt and nut to be installed in both lower brackets as shown in Figure 6.

The bolt head is installed opposite the air spring. The nut will fit inside the roll plate cavity.

Tighten the nut securely.



6

7 LOWER PLATE

Place the lower roll plate on the bottom of the air spring (with the rounded side towards the air spring).

Install the two carriage bolts provided through the lower bracket into the square holes of the legs (with the threaded end of the carriage bolt pointing away from the air spring). Then, install the lower bracket to the air spring using the two countersink capscrews with a 7/32" allen wrench. The legs of the bracket must be installed towards the opposite side to the airline fitting.

Tighten the countersink capscrews securely.

Repeat Steps 4-7 on the other air spring.



7

8 DETACH BRAKE LINE

Remove and discard the 8mm bolt that holds the rear brake line distribution block to the axle tube.

Using the shorter 8mm bolt supplied, attach the HP1145 bracket to the axle tube in the same location, with the bent end pointing down and towards the rear.

Torque to 19 ft-lbs, 27 N•m.

Move the distribution block towards the rear hole using the 5/16" flange head bolt and the flange head nut.

Torque to 19 ft-lbs, 27 N•m



8

9 INSTALL AIR SPRING ASSEMBLY

Insert the air spring assembly between the jounce bumper and the axle plate with the 90° airline fitting pointing towards the center of the vehicle. Some vehicles may require the frame to be raised slightly to attain enough clearance to insert the air spring assembly. Rotate the lower mounting bracket to position one leg in front of the axle pad and the other leg behind the axle pad.

Note: Ensure sufficient clearance exists between the brake lines and the carriage bolt



9

- 10** Install one 3/8" flat washer on to each of the 3/8" x 11/4" bolts. Insert these bolts down through the jounce bumper holes in the frame and into the slotted holes of the upper mounting bracket, insert the HP0095 flat plate. Upper bracket support on to the protruding threaded portion of the bolts. Install one 3/8" flat washer and one 3/8" nylock nut on each bolt.

Leave these bolts loose until the final adjustments of the air springs are completed.



10

11 AXLE STRAPS

Loosely install the axle straps to the carriage bolts using the 3/8" flat washers and the 3/8" nylock nuts provided.

Repeat Steps 8-11 on the other air spring assembly



11

12 ADJUSTING THE AIR SPRING

The upper bracket allows for more adjustment than the lower bracket. For this reason, adjust the lower bracket so that the air spring is centered over the axle first. Then adjust the upper bracket to achieve the correct air spring alignment (as shown in Figure 12).

- 13** Once the air springs are correctly aligned, torque the upper bracket to frame bolts to 20 ft-lbs, 40 N•m.

Then, torque the 3/8" capscrews that secure the upper bracket to the air spring to 20 ft-lbs, 27 N•m.

- 14** Torque the axle strap carriage bolts evenly to 20 ft-lbs, 27 N•m.

Repeat Steps 12-14 on the other air spring assembly

Double check the clearance between the carriage bolts and the vehicles brake lines, adjust if necessary to attain adequate clearance.

15 REATTACH BRAKE LINE

On the driver's side assembly: insert a 5/16" flange head bolt up into the forward hole of the upper mounting bracket.

Place the HP0011 bracket onto this bolt so that the long end points down. Place a 5/16" flat washer and the 5/16" nylock nut on the bolt loosely. Place the loop clamp onto the emergency brake cable using a 5/16" flange head bolt. Insert it through the loop clamp and into the HP0011 bracket. Secure with a 5/16" flat washer and a nylock nut.

Now, position the HP0011 bracket to achieve the most clearance between the air spring and the emergency brake cable.

Torque the 5/16" bolt to 19 ft-lbs.

16 INSTALL HEAT SHIELD

Bend tabs on the heat shield so the required 1/2" of dead space exists between the heat shield and exhaust when attached.

Attach the heat shield to the exhaust pipe using two ring clamps (shown in Figure 16 on following page). Each hose clamp holds a tab against exhaust pipe.

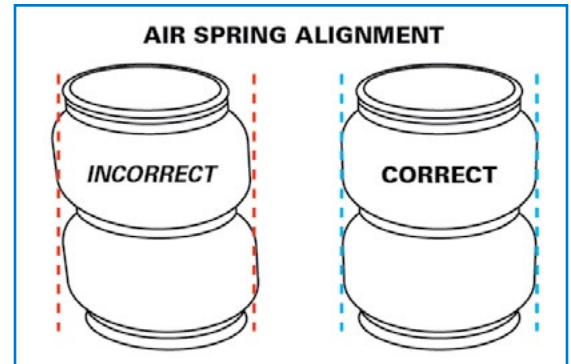

12



13



14



15

17 INSTALL AIR LINE

PLEASE NOTE: This kit contains push-to-connect fittings; using scissors or wire cutters to cut the nylon airline will distort the line and cause the connection to leak. THE AIRLINE MUST BE CUT OFF SQUARELY WITH THE NYLON HOSE CUTTER PROVIDED IN THIS KIT OR A SHARP UTILITY KNIFE

Provided in air spring kit are two fill valves. The most common place to install is in place of license plate fasteners. Alternatively, two 5/16" holes can be drilled in a convenient location.

Cut air line assembly into two equal lengths with hose cutter.

Install one air line, route the nylon air line to an air spring fitting and cut the hose. Moisten the end of the air line prior to inserting it into the fitting and push it in until it stops. Repeat with the other fill valve.

Secure airlines using the tie-straps, away from moving items and heat sources.

Place a 5/16" nut on the air valve. Leave enough of the inflation valve in front of the nut to extend through the hole, install a flat washer, and 5/16" nut and cap (reference Figure 17 for assembly). There should be enough valve exposed after installation—approximately 1/2"—to easily apply a pressure gauge or an air chuck.

If an in-cab inflation kit is being installed, follow the instructions provided with that kit now.

18 CHECK SYSTEM FOR LEAKS

Inflate both air springs to 90 psi and then use a mixture of dish soap and water on all air line connections to detect any air leaks. Large, expanding bubbles indicate a leak (as shown in Figure 18). Repair as necessary and retest.

Inflate air springs to a predetermined value and on following day recheck pressure. If one or both of air springs have lost pressure, an air leak is present. Leak must be repaired, and then retested until no leaks exist.



16

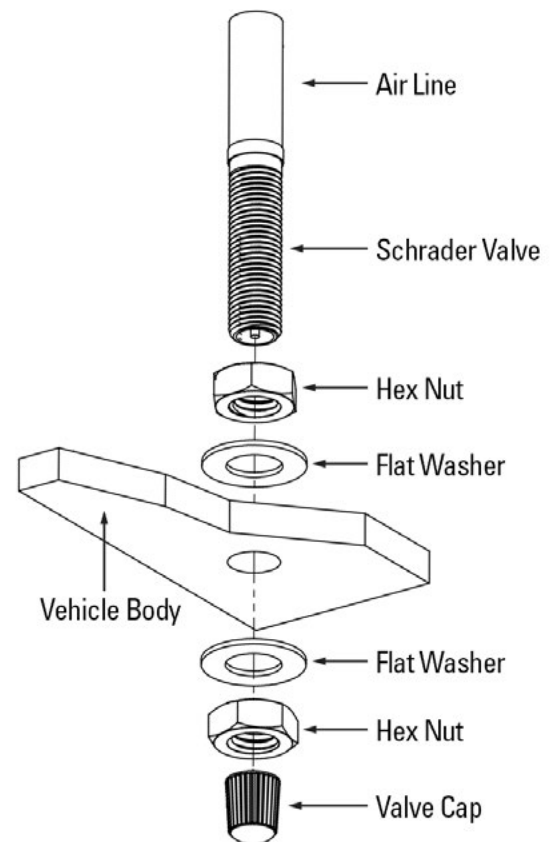

17



18

AFTER COMPLETING THE INSTALLATION

PLEASE REMEMBER:

Install wheels and torque fasteners to manufacturer's specifications.

Re-torque all fasteners after first 500 miles of driving.

For safe and proper operation, never operate the vehicle under minimum of 10 psi or over maximum of 100 psi in air springs. Staying within pressure limit will ensure maximum air spring life. Failure in doing so may result in a void warranty (see **Note** below).

NOTE: Do not exceed maximum vehicle payload. Failure to do so may result in failure of the air suspension kit and/or damage to your vehicle.

Thank you again, and congratulations on the installation of the air suspension kit.

OPTIONAL ACCESSORIES

Optional dual needle air gauges are available to monitor pressure in each spring from vehicle cab, as well as a full line of air compressors, air tanks, and solenoids built to work with and control your air spring system.

OPERATING YOUR VEHICLE WITH AIR SUSPENSION

Air springs have minimum and maximum pressure requirements. Never operate your vehicle with less than 10 psi in air spring and never inflate air springs over 100 psi. Damage to air springs will result.

Check air pressure in air springs daily for first couple of days to ensure a leak has not developed. Air springs are designed to maintain the vehicles stock ride height with a load. Do not use the air springs as a means to lift vehicle with no load. This will result in a harsh ride.

SERVICING YOUR VEHICLE WITH AIR SUSPENSION

When lifting the vehicle with a floor jack or hoist on the frame, never allow the air spring to limit the travel of the axle. Try to always jack the vehicle on the axle. Suspending the axle with the air spring limiting the axle travel will damage the air spring and void the air spring warranty.

WARRANTY

To be eligible for warranty, the owner must submit their warranty card or register online within 30 days of the purchase date.

NOTE: The owner's warranty will be void if air springs are run with less than the minimum of 10 psi.

.....