

Installation Manual



10368-X KIT

RAM 3500 (2WD/4WD)*

Eliminate your vehicle's sag, sway and bottoming out while providing added support for an overall smooth and safe ride with this extreme duty air suspension kit. Rated for up to 7500 lbs of load-leveling capacity⁺, this kit is ideally suited for those towing/hauling big loads on a regular basis.

* See application guide for proper fitment.



WARNING: This product can expose you to the chemical Hexavalent Chromate, which is known to the State of California to cause cancer and birth defects or other reproductive harm. *For more information go to www.P65Warnings.ca.gov*

IMPORTANT

This air suspension kit will not increase the GVWR (*Gross Vehicle Weight Rating*), as the GVWR is determined by the vehicle manufacturer. **Do not exceed the maximum capacity listed by the vehicle manufacturer.**

Safety Warning!

Serious personal injury or death may result from an air spring failure or accident due to improper installation or air spring pressure operation or maintenance. Please read and abide the instructions, safety recommendations and maintenance suggestions throughout this manual.

Safety Warning!

Inflating an unsecured air spring is dangerous. If it bursts, it could be hurled into the air with explosive force resulting in serious personal injury or death. Never inflate an air spring unless it is secured to the vehicle.

Safety Warning!

Removing and replacing air springs can be dangerous. This is only a job for a qualified service professional. Never perform air spring service procedures without proper training, tools, and equipment.

KIT CONTENTS

Reference the kit explosion diagram on the following page for part assembly.

KIT CONTENTS			REQUIRED TOOLS		
	QTY	PART #			
A Extreme Duty Air Bag	2	HP10068-X	• Hoist or Floor Jack		
B Roll Plate	4	HP10069	• Safety Stands		
C Bracket, Lower Mount	2	HP1616	• Safety Glasses		
D Bracket, Upper Passenger	1	HP1617	• Torque Wrench		
E Bracket, Upper Driver	1	HP1618	• Standard Combination Wrenches		
F Bracket, Upper Support	2	HP1619	• 7/32" Hex Allen Wrench		
G Axle Strap	2	HP1383	• 1-1/8" Wrench or Deep Socket		
H U-Bolt, 6 5/8" X 4 5/8" Square	2	HP1612	• 9/16" Crows-foot Adapter		
I Bolt, 3/8" - 24 X 7/8" Hex Head	8	HP1002	• Ratchet		
J Bolt, 3/8" - 16 X 7" Carriage	4	HP1409	• Metric & Standard Sockets		
K Bolt, 3/8" - 16 X 1.5" Hex Head	4	C18018	• Hose Cutter (included) or Sharp Utility Knife		
L Washer, 3/8" Flat	16	C18006	• Pipe Thread Sealant		
M Washer, 3/8" Split Lock	8	C18007	• Spray Bottle with Dish Soap/Water		
N Nut, 3/8" Nylon Lock	4	HP1000	• Air Compressor/Compressed Air Source (to test/fill air springs)		
O Nut, 3/8" Serrated Flange	8	HP1338			
P Heat Shield	1	HP0012			
Q Worm Gear Ring Clamp	2	HP1001			
R Fitting, 90° Brass	2	HP1245			
S Airline Hose Assembly	1	HP1344			
T Tie Strap	6	C11618			

Please make sure all the items shown in this explosion diagram are provided in your kit before starting the installation.

PASSENGER SIDE ASSEMBLY SHOWN:

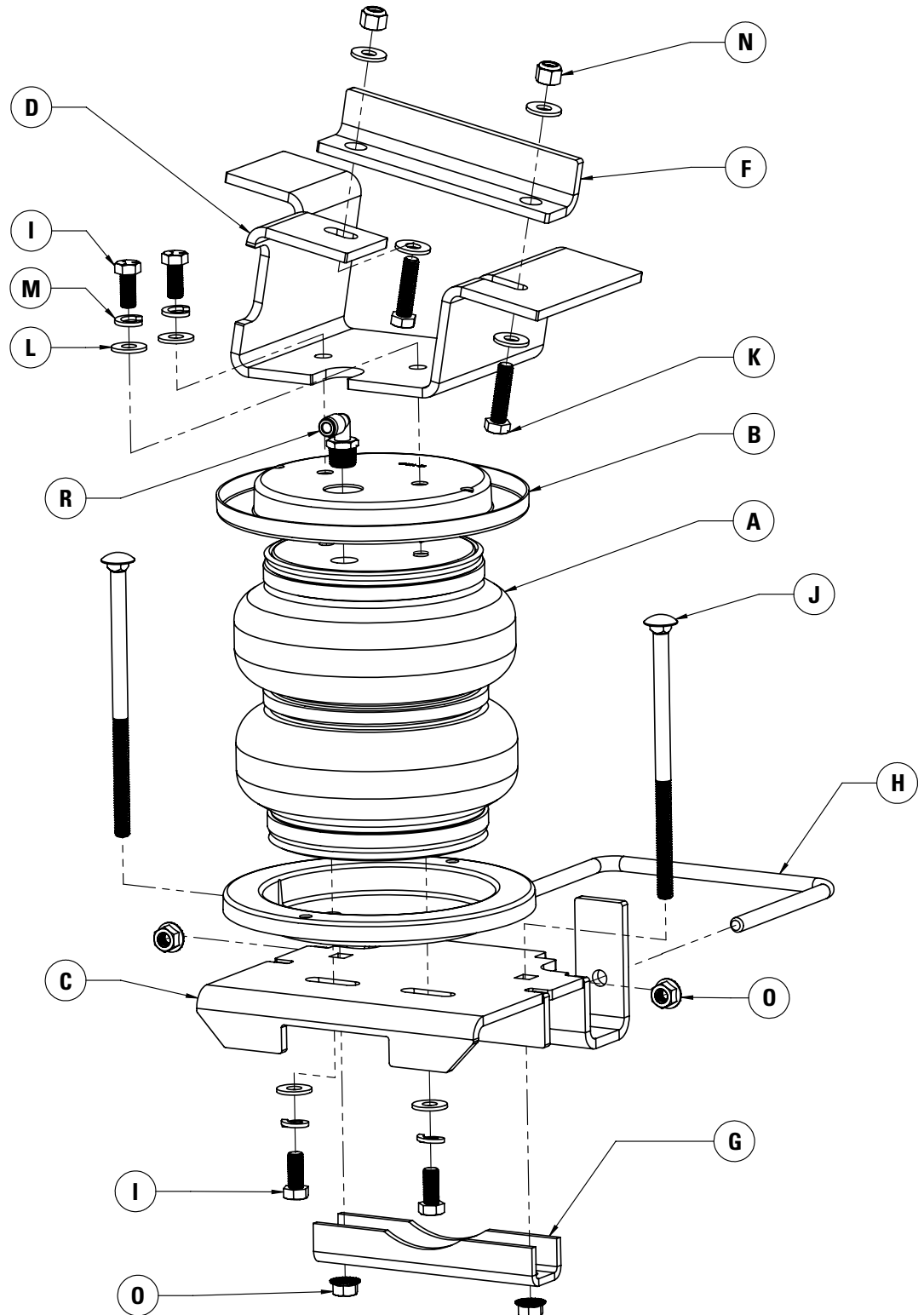

BEFORE STARTING THE INSTALLATION:

1. Ensure the application information is correct for the make, model and year of the vehicle you are installing the kit on.
2. Some vehicles are equipped with a rear wheel brake proportioning valve. Check with the manufacturer before installing the air spring kit, as it may affect braking performance.
3. It is recommended to use a good quality anti-seize on all fasteners. This will reduce the chance of corrosion on the fasteners and will help facilitate removal, if required at a later date.

PLEASE NOTE:

This kit contains push-to-connect fittings; using scissors or wire cutters to cut the nylon airline will distort the line and cause the connection to leak. THE AIRLINE MUST BE CUT OFF SQUARELY WITH THE NYLON HOSE CUTTER PROVIDED IN THIS KIT OR A SHARP UTILITY KNIFE.

1 MEASURE STOCK RIDE HEIGHT

Park the vehicle on a level surface.

Using a measuring tape, measure the distance between the center of the wheel hub and the bottom of the fender well (as shown in Figure 1) this will give you your ride height.

Note the ride height for all four corners.

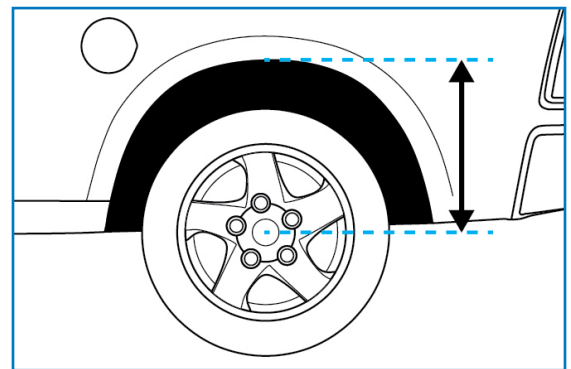

1

2 REMOVE REAR WHEELS

Place wheel chocks in front of and behind both front wheels.

Raise the rear of the truck high enough to remove both wheels and attain a comfortable working height.

Place two jack stands under rear axle (shown in Figure 2).

Lower the vehicle until the axle is supported by the jack stands.

Remove rear wheels.

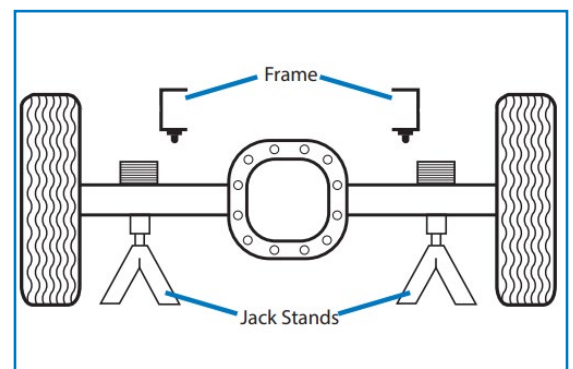

2

3 REMOVE JOUNCE BUMPER

Unbolt and remove both jounce bumpers (as shown in Figure 3 on following page).

You can safely dispose of jounce bumpers and hardware as they will not be reused in this installation.

Drop the axle down low enough to later set the air spring assemblies into position between the frame and the axle.

4 LOOSEN AXLE VENT LINE

Using a large flat screwdriver, pry out the axle vent tube line holder from the stock upper 5th wheel bracket.

Let the hose hang, it will be re-installed during reassembly.

5 ASSEMBLING AIR SPRINGS

Set the roll plates on top of each air spring, ensuring that all holes line up.

Install the 90° fittings into the port on the top of each air spring (as shown in Figure 5).

Tighten the fittings finger-tight plus 1 1/2 turns. The use of thread sealant or Teflon tape is recommended.

6 UPPER BRACKETS

Place the Passenger side upper bracket (as shown in Figure 6) on top of one air spring assembly.

Place the Driver side upper bracket on top of the other air spring assembly.

Attach brackets with two 3/8" – 24 x 7/8" hex bolts, two 3/8" lock washers and two 3/8" flat washers.

Torque bolts to 20 ft-lbs (27 N•m).

7 LOWER BRACKET

Flip over the assemblies and set the roll plates into position on the bottoms of the air springs

Insert two 3/8" – 16 x 7" carriage bolts down through the top of the lower bracket. (See Figure 7 for reference).

Note: When installing the lower bracket onto the assemblies make sure the flange on the lower bracket is opposite of the fitting on top of the air spring.

Attach the lower bracket to the springs with two 3/8" – 24 x 7/8" hex bolts, two 3/8" lock washers and two 3/8" flat washers. Tighten hardware finger-tight only at this time.

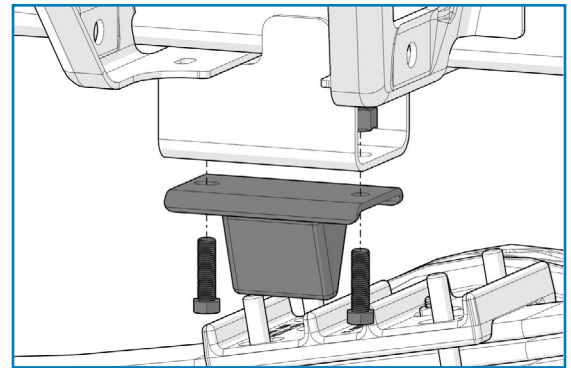

3

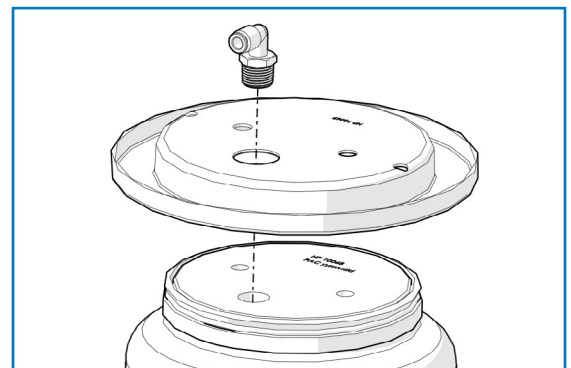

5

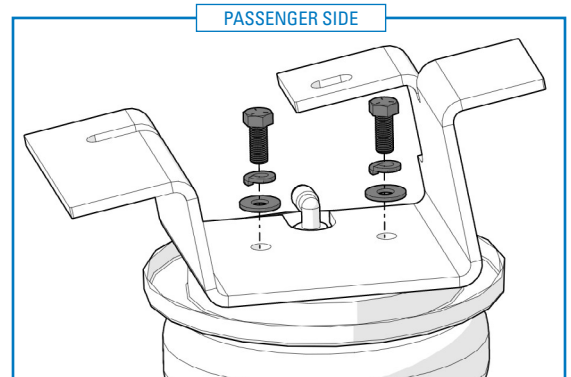

6

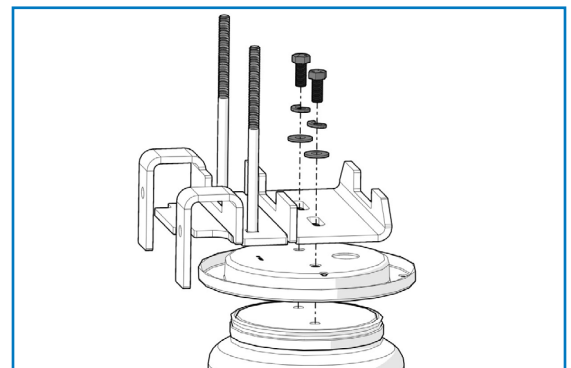

7

8 INSTALLING AIR SPRING ASSEMBLIES

With the axle dropped (as stated in Step 2), set the Driver and Passenger assemblies into position on the axle. (See Figure 8A)

Note: When setting the Driver side assembly into position, be careful not to set the assembly onto the axle vent tubing and hose

On both sides, install the square U-bolt around the leaf spring stack and through the lower bracket flanges. (See Figure 8B)

Install two 3/8" serrated flange nuts onto the U-bolt and leave loose at this time.

Push the lower bracket against the stock U-bolt stack as tight as possible.

9 INSTALLING THE AXLE STRAP

Install the axle strap onto the carriage bolts under the axle and attach with two 3/8" serrated flange nuts. (See Figure 9 for reference).

Using a 9/16" crows-foot adapter, evenly torque the leaf spring U-bolts to 10 lb.-ft. (13.6 N•m), then torque the lower axle clamp bar hardware to 16 lb.-ft. (21.7 N•m).

Repeat on the opposite side.

10 INSTALLING UPPER SUPPORT BRACKETS

Raise the axle up so that the upper brackets touch the frame.

Set the upper support bracket assemblies with the flange on the brace facing inward. Insert two 3/8" - 16 X 1.5" bolts and two 3/8" flat washers through the existing holes in the frame, then through the upper support brackets. (See Figure 10)

Note: The upper support brackets must face inward when installing onto the frame.

Install two 3/8" flat washers and two 3/8" lock nuts onto the bolts.

Torque the hardware to 31 ft-lbs (42 N•m).

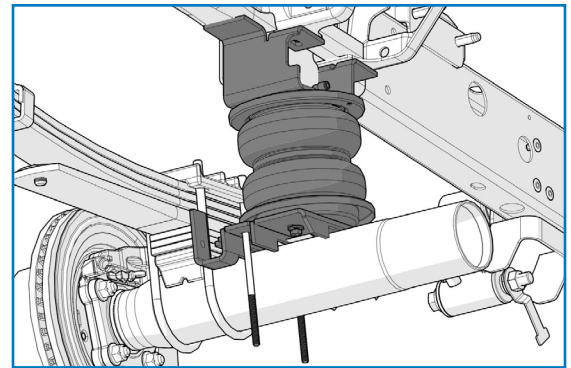

8A

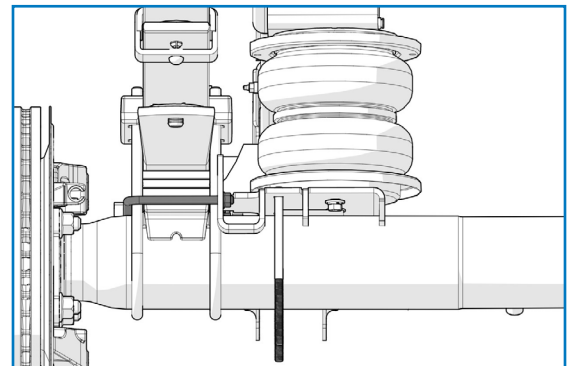

8B

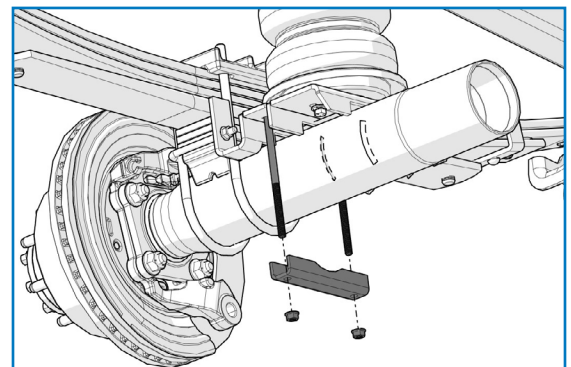

9

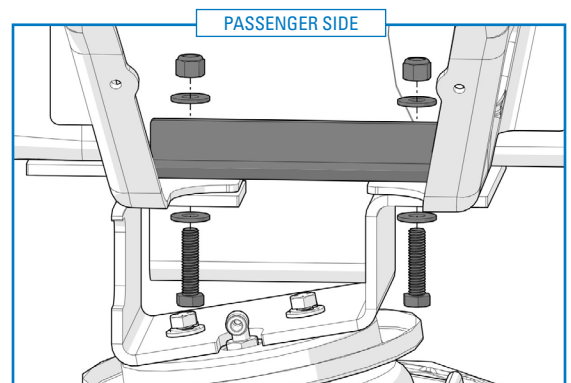

10

11 REATTACHING AXLE VENT LINE

Align the air springs as perpendicular to the upper and lower brackets as possible (see Figure 11). When aligned, tighten the air spring lower mounting bolts to 20 ft-lbs (27 N•m)

Note: It is recommended to use a 9/16" ratchet wrench to tighten the bolts. It may be required to flip the open end of the wrench over several times (on the shock side of the bracket) to tighten the bolt far enough to get the boxed ratcheting end on the bolt.

Re-attach the axle vent tube line holder previously loosened in Step 4.

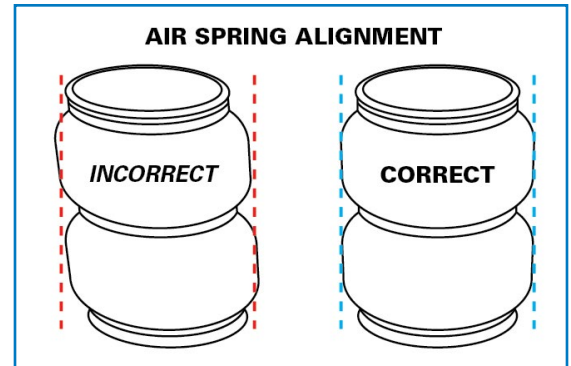

11

12 INSTALL AIR LINE

PLEASE NOTE: This kit contains push-to-connect fittings; using scissors or wire cutters to cut the nylon airline will distort the line and cause the connection to leak. THE AIRLINE MUST BE CUT OFF SQUARELY WITH THE NYLON HOSE CUTTER PROVIDED IN THIS KIT OR A SHARP UTILITY KNIFE

Provided in air spring kit are two fill valves. The most common place to install is in place of license plate fasteners. Alternatively, two 5/16" holes can be drilled in a convenient location.

Cut air line assembly into two equal lengths with hose cutter.

Install one air line, route the nylon air line to an air spring fitting and cut the hose. Moisten the end of the air line prior to inserting it into the fitting and push it in until it stops. Repeat with the other fill valve.

Secure airlines using the tie-straps, away from moving items and heat sources.

Place a 5/16" nut on the air valve. Leave enough of the inflation valve in front of the nut to extend through the hole, install a flat washer, and 5/16" nut and cap (reference Figure 12 for assembly). There should be enough valve exposed after installation—approximately 1/2"—to easily apply a pressure gauge or an air chuck.

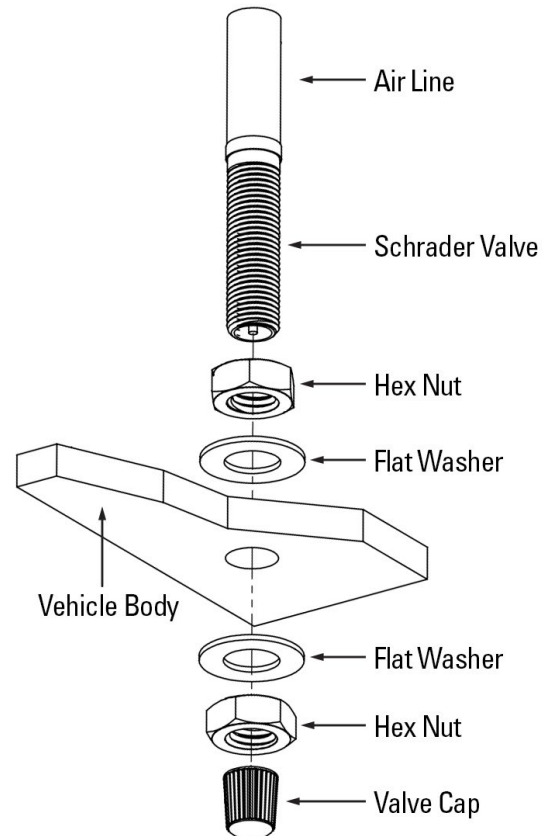

12

If an in-cab inflation kit is being installed, follow the instructions provided with that kit now.

13 CHECK SYSTEM FOR LEAKS

Inflate both air springs to 90 psi and then use a mixture of dish soap and water on all air line connections to detect any air leaks. Large, expanding bubbles indicate a leak (as shown in Figure 13). Repair as necessary and retest.

Inflate air springs to a predetermined value and on following day recheck pressure. If one or both of air springs have lost pressure, an air leak is present. Leak must be repaired, and then retested until no leaks exist.

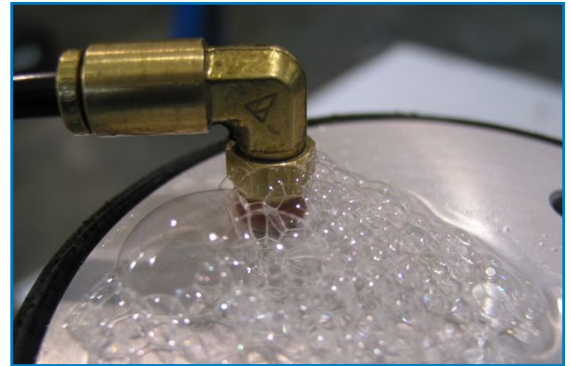

13

14 AFTER COMPLETING THE INSTALLATION

PLEASE REMEMBER:

Install wheels and torque fasteners to manufacturer's specifications.

Re-torque all fasteners after first 500 miles of driving.

For safe and proper operation, never operate the vehicle under minimum of 10 psi or over maximum of 100 psi in air springs. Staying within pressure limit will ensure maximum air spring life. Failure in doing so may result in a void warranty (see **Note** below).

NOTE: Do not exceed maximum vehicle payload. Failure to do so may result in failure of the air suspension kit and/or damage to your vehicle.

Thank you again, and congratulations on the installation of the air suspension kit.

OPTIONAL ACCESSORIES

Optional dual needle air gauges are available to monitor pressure in each spring from vehicle cab, as well as a full line of air compressors, air tanks, and solenoids built to work with and control your air spring system.

OPERATING YOUR VEHICLE WITH AIR SUSPENSION

Air springs have minimum and maximum pressure requirements. Never operate your vehicle with less than 10 psi in air spring and never inflate air springs over 100 psi. Damage to air springs will result.

Check air pressure in air springs daily for first couple of days to ensure a leak has not developed. Air springs are designed to maintain the vehicles stock ride height with a load. Do not use the air springs as a means to lift vehicle with no load. This will result in a harsh ride.

SERVICING YOUR VEHICLE WITH AIR SUSPENSION

When lifting the vehicle with a floor jack or hoist on the frame, never allow the air spring to limit the travel of the axle. Try to always jack the vehicle on the axle. Suspending the axle with the air spring limiting the axle travel will damage the air spring and void the air spring warranty.

WARRANTY

To be eligible for warranty, the owner must submit their warranty card or register online within 30 days of the purchase date.

NOTE: The owner's warranty will be void if air springs are run with less than the minimum of 10 psi.

