

# Installation Manual



## 10002-X KIT

Dodge RAM 2500-3500 4WD\*  
RAM Mega Cab 2500 & 3500 4WD\*

*Eliminate your vehicle's sag, sway and bottoming out while providing added support for an overall smooth and safe ride with this extreme duty air suspension kit. Rated for up to 7500 lbs of load-leveling capacity<sup>+</sup>, this kit is ideally suited for those towing/hauling big loads on a regular basis.*

\* See application guide for proper fitment.

+ Applications vary. Never exceed manufacturer's recommended Gross Vehicle Weight Rating



**WARNING:** This product can expose you to the chemical Hexavalent Chromate, which is known to the State of California to cause cancer and birth defects or other reproductive harm. *For more information go to [www.P65Warnings.ca.gov](http://www.P65Warnings.ca.gov)*

**IMPORTANT**

This air suspension kit will not increase the GVWR (*Gross Vehicle Weight Rating*), as the GVWR is determined by the vehicle manufacturer. **Do not exceed the maximum capacity listed by the vehicle manufacturer.**

*Safety Warning!*

Serious personal injury or death may result from an air spring failure or accident due to improper installation or air spring pressure operation or maintenance. Please read and abide the instructions, safety recommendations and maintenance suggestions throughout this manual.

*Safety Warning!*

Inflating an unsecured air spring is dangerous. If it bursts, it could be hurled into the air with explosive force resulting in serious personal injury or death. Never inflate an air spring unless it is secured to the vehicle.

*Safety Warning!*

Removing and replacing air springs can be dangerous. This is only a job for a qualified service professional. Never perform air spring service procedures without proper training, tools, and equipment.

**KIT CONTENTS**

*Reference the kit explosion diagram on the following page for part assembly.*

KIT CONTENTS			QTY	PART #	REQUIRED TOOLS
<b>A</b>	Extreme Duty Air Bag	2	HP10068-X	<ul style="list-style-type: none"> <li>• Hoist or Floor Jack</li> <li>• Safety Stands</li> <li>• Safety Glasses</li> <li>• Torque Wrench</li> <li>• Standard Combination Wrenches</li> <li>• 7/32" Hex Allen Wrench</li> <li>• 1-1/8" Wrench or Deep Socket</li> <li>• Ratchet</li> <li>• Metric &amp; Standard Sockets</li> <li>• Hose Cutter (included) or Sharp Utility Knife</li> <li>• Pipe Thread Sealant</li> <li>• Spray Bottle with Dish Soap/Water</li> <li>• Air Compressor/Compressed Air Source (to test/fill air springs)</li> </ul>	
<b>B</b>	Roll Plate	4	HP10069		
<b>C</b>	Upper Frame Bracket	2	HP1647		
<b>D</b>	Upper Air Bag Bracket	2	HP1648		
<b>E</b>	Lower Bracket	2	HP1649		
<b>F</b>	Axle Strap	2	HP1383		
<b>G</b>	U-Bolt, 6.5" X 5.5" Square	2	HP1015		
<b>H</b>	Bolt, 3/8" – 24 X 7/8" Hex Head	8	HP1002		
<b>I</b>	Bolt, 3/8" – 16 X 1.25" Carriage	4	HP1149		
<b>J</b>	Bolt, 3/8" – 16 X 7" Carriage	4	HP1409		
<b>K</b>	Bolt, M10 X 1.5 X 35 mm Hex Head	4	HP1134		
<b>L</b>	Washer, 3/8" Flat	16	C653		
<b>M</b>	Washer, 3/8" Split Lock	4	C18007		
<b>N</b>	Nut, 3/8" Nylon Lock	12	HP1000		
<b>O</b>	Heat Shield	1	HP0012		
<b>P</b>	Worm gear Ring Clamp	2	HP1001		
<b>Q</b>	Fitting, 90° Brass	2	HP1245		
<b>R</b>	Airline Hose Assembly	1	HP1344		
<b>S</b>	Tie Strap	6	C11618		

Please make sure all the items shown in this explosion diagram are provided in your kit before starting the installation.

**DRIVER SIDE ASSEMBLY SHOWN:**

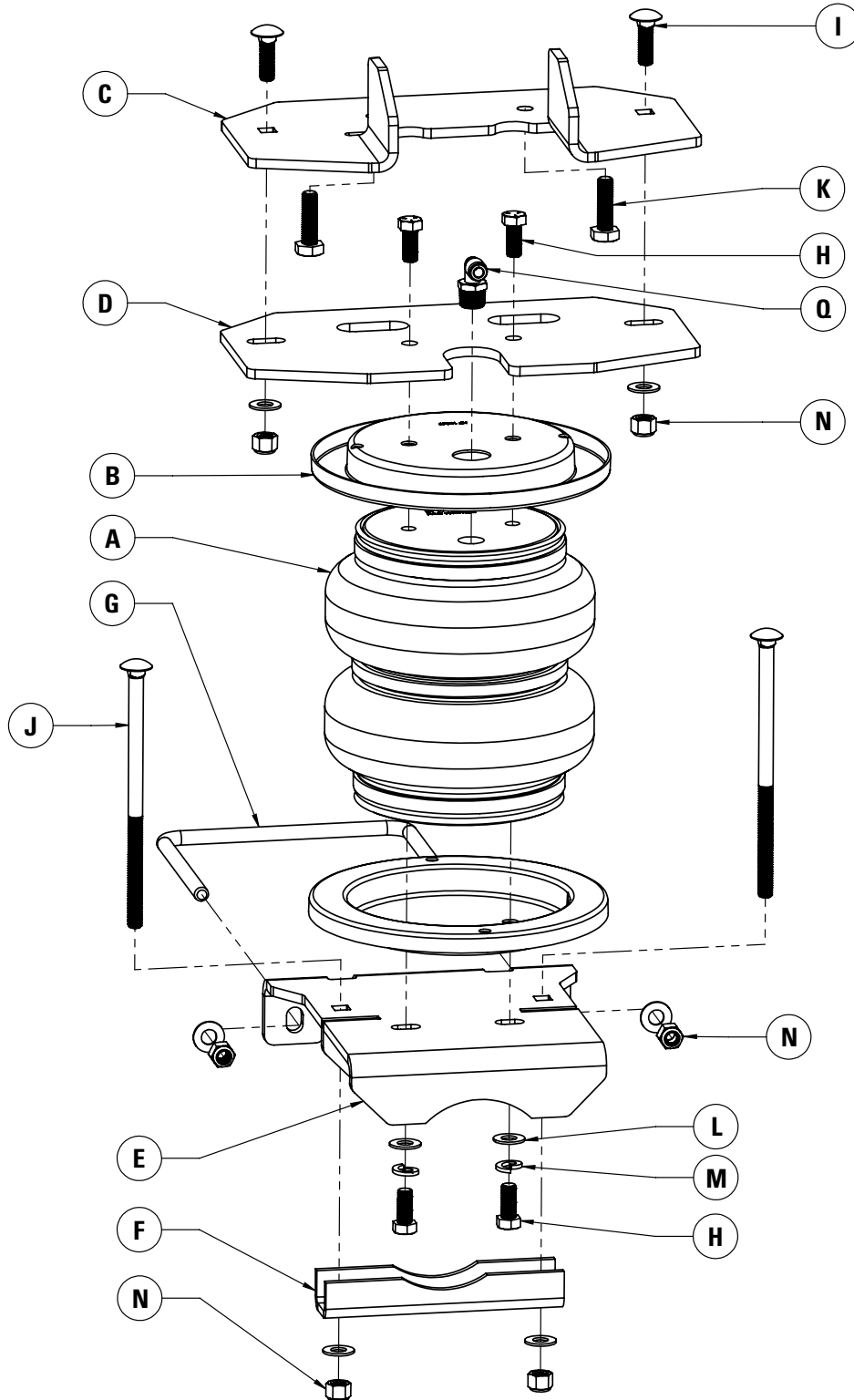

**BEFORE STARTING THE INSTALLATION:**

1. Ensure the application information is correct for the make, model and year of the vehicle you are installing the kit on.
2. Some vehicles are equipped with a rear wheel brake proportioning valve. Check with the manufacturer before installing the air spring kit, as it may affect braking performance.
3. It is recommended to use a good quality anti-seize on all fasteners. This will reduce the chance of corrosion on the fasteners and will help facilitate removal, if required at a later date.

**PLEASE NOTE:**

***This kit contains push-to-connect fittings; using scissors or wire cutters to cut the nylon airline will distort the line and cause the connection to leak. THE AIRLINE MUST BE CUT OFF SQUARELY WITH THE NYLON HOSE CUTTER PROVIDED IN THIS KIT OR A SHARP UTILITY KNIFE.***

**1 MEASURE STOCK RIDE HEIGHT**

Park the vehicle on a level surface. Remove any unnecessary weight from the vehicle to attain a Normal Ride Height. This is important for correct initial air spring set-up and adjustment.

Using a measuring tape, measure the distance between the center of the wheel hub and the bottom of the fender well (as shown in Figure 1) this will give you your ride height.

Note the ride height for all four corners.

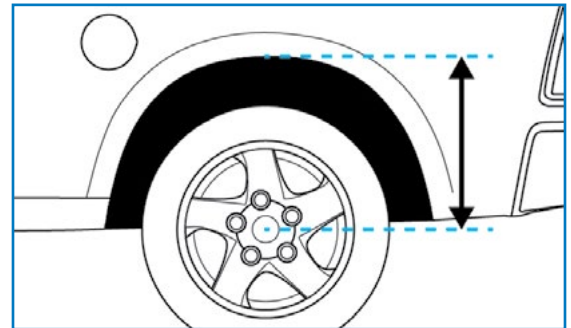

1

**2 REMOVE REAR WHEELS**

Place wheel chocks in front of and behind both front wheels.

Raise the rear of the truck high enough to remove both wheels and attain a comfortable working height.

Place two jack stands under rear axle (shown in Figure 2).

Lower the vehicle until the axle is supported by the jack stands.

Remove rear wheels.



2

**3 REMOVE JOUNCE BUMPER**

Remove the two bolts securing jounce bumper to frame rail on both sides of the vehicle (see Figure 3).

Discard the hardware as it will not be reused in this installation.

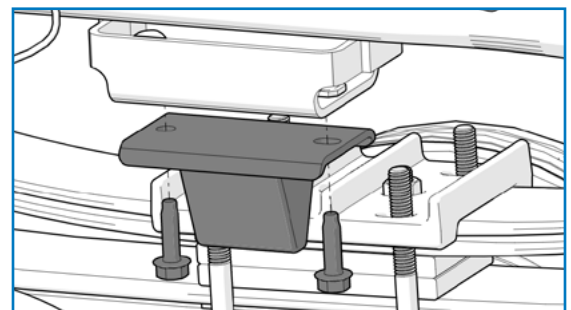

3

#### 4 INSTALL AIR FITTINGS

Set a roll plate over the top surface of each air spring (as shown in Figure 4). Insert the air fitting into the large threaded hole and tighten finger tight plus an additional 1.5 turns. The use of thread sealant or Teflon tape is recommended.

#### 5 ATTACH UPPER BAG PLATES

Place the upper bag plate on the roll plate, ensuring the holes in the air bag, roll plate and bracket all align.

Attach the bag plate to the air bag using two 3/8" – 24 X 7/8" bolts.

Torque bolts to 20 ft-lbs (27 N•m).

#### 6 ATTACH LOWER BRACKET

Insert two 3/8" – 16 X 7" carriage bolts (as shown in Figure 5) through the square holes in the lower bracket.

**Note: Carriage bolts must be inserted before attaching the lower bracket to the air bag as the roll plate will cover the carriage bolt holes.**

Place a roll plate and the lower bracket on the bottom surface of the air bag with the U-Bolt mounting flange opposite the air fitting.

Ensure all mounting holes are aligned and secure with two 3/8" – 24 X 7/8" bolts, two 3/8" lock washers and two 3/8" flat washers.

Do not fully tighten yet to allow for adjustment during installation.

#### 7 INSTALL UPPER FRAME BRACKET

Place the upper frame bracket on the jounce bumper mounting plate (as shown in Figure 7) with the vertical flanges resting on the inside surface of the frame.

Attach the bracket by installing two M10 X 1.5 X 35 mm hex head bolts through the bracket into the holes previously occupied by the jounce bumper hardware.

Torque the bolts to 30 ft-lbs (40 N•m)

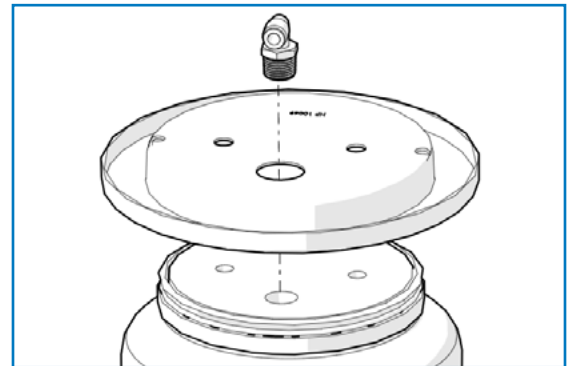

4

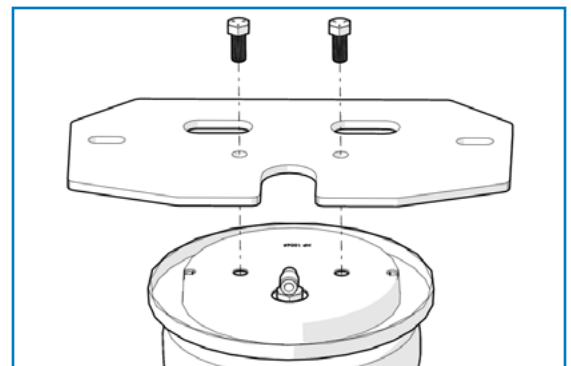

5

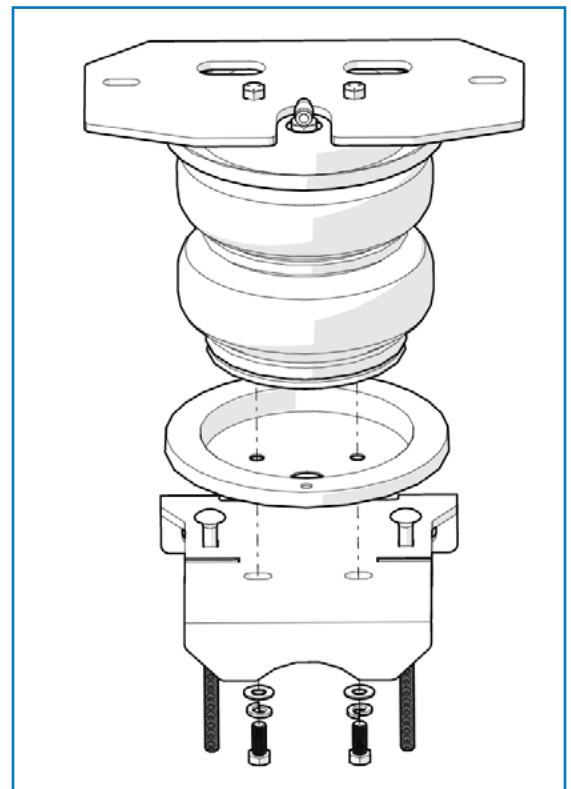

6



## 8 INSTALL AIR SPRING ASSEMBLIES

**NOTE:** It may be necessary to raise the frame of the truck a few inches to allow more clearance to install the spring assemblies

Set the driver's side spring assembly in the vehicle (as shown in Figures 8A & 8B).

Ensure the rearward lower carriage bolt does not contact the brake lines when the assembly is fully seated on the axle. For some models, the carriage bolt may sit outside the brake lines in order to achieve this.

Attach the assembly to the upper frame bracket with two 3/8" – 16 X 1.25" carriage bolts, two 3/8" flat washers and two 3/8" nylon lock nuts. (See Figure 8B)

Slide the upper frame bracket and the airbag on the lower plate to achieve the best vertical spring alignment as per Figure 8C.

Torque the carriage bolt lock nuts to 20 ft-lbs (27 N•m)

Torque the lower airbag bolts to 20 ft-lbs (27 N•m).

Repeat for passenger side assembly.

**NOTE:** On some models, it may be necessary to cut a small notch in the lower roll plate on the driver's side if there is interference with the axle vent tube (Circled in red in Figure 8A)

## 9 SECURE LOWER BRACKET TO LEAF PACK

Install the U-Bolt around the leaf pack and into the lower bracket slotted holes (as shown in Figure 9). Secure with two 3/8" flat washers and two 3/8" nylon lock nuts.

Torque lock nuts to 20 ft-lbs (27 N•m)

## 10 ATTACH AXLE STRAP

Place the axle strap on the two carriage bolts (as shown in Figure 10) and secure with two 3/8" flat washers and two 3/8" nylon lock nuts.

Torque the lock nuts to 20 ft-lbs (27 N•m).

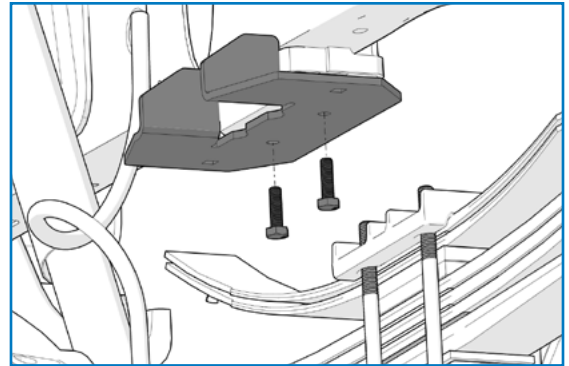

7

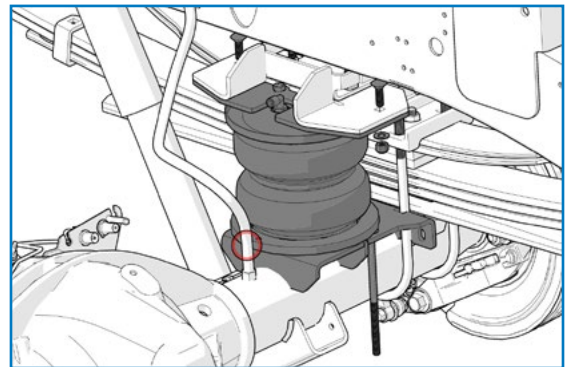

8A

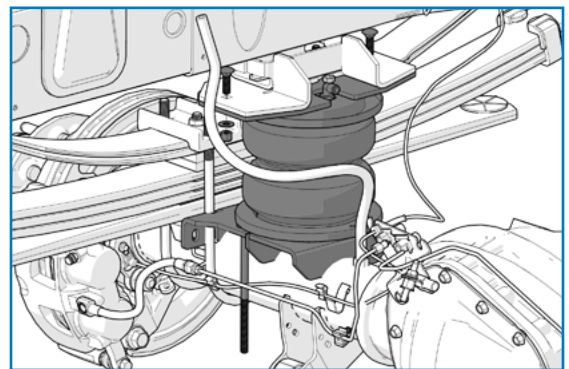

8B

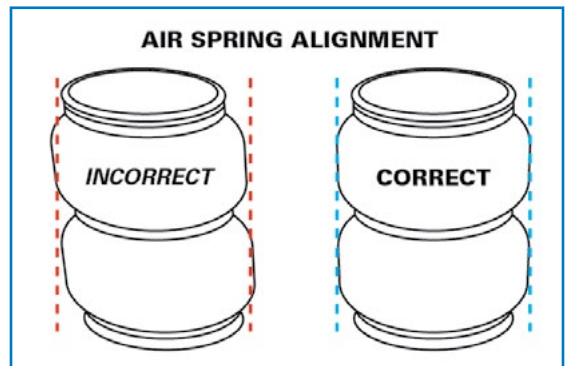

8C

## 11 INSTALL HEAT SHIELD

Bend tabs on the heat shield so the required  $\frac{1}{2}$ " of dead space exists between the heat shield and exhaust when attached.

Attach the heat shield to the exhaust pipe on passenger side using two ring clamps (shown in Figure 11). Each hose clamp holds a tab against exhaust pipe.

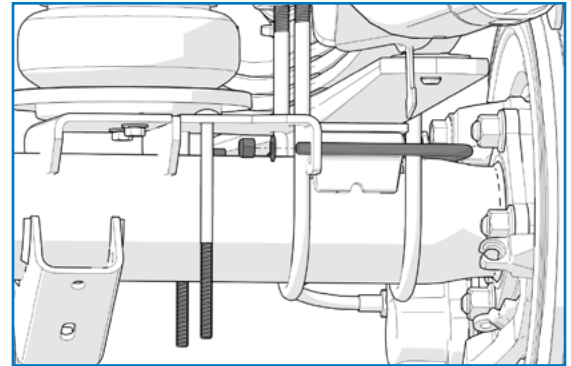

9

## 12 INSTALL AIR LINE

**PLEASE NOTE: This kit contains push-to-connect fittings; using scissors or wire cutters to cut the nylon airline will distort the line and cause the connection to leak. THE AIRLINE MUST BE CUT OFF SQUARELY WITH THE NYLON HOSE CUTTER PROVIDED IN THIS KIT OR A SHARP UTILITY KNIFE**

Provided in air spring kit are two fill valves. The most common place to install is in place of license plate fasteners. Alternatively, two  $\frac{5}{16}$ " holes can be drilled in a convenient location.

Cut air line assembly into two equal lengths with hose cutter.

Install one air line, route the nylon air line to an air spring fitting and cut the hose. Moisten the end of the air line prior to inserting it into the fitting and push it in until it stops. Repeat with the other fill valve.

Secure airlines using the tie-straps, away from moving items and heat sources.

Place a  $\frac{5}{16}$ " nut on the air valve. Leave enough of the inflation valve in front of the nut to extend through the hole, install a flat washer, and  $\frac{5}{16}$ " nut and cap (reference Figure 12 for assembly). There should be enough valve exposed after installation—approximately  $\frac{1}{2}$ "—to easily apply a pressure gauge or an air chuck.

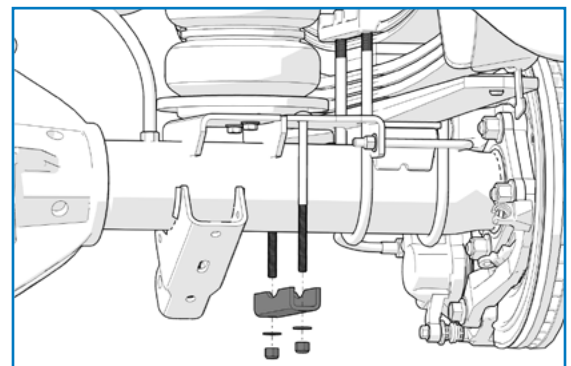

10

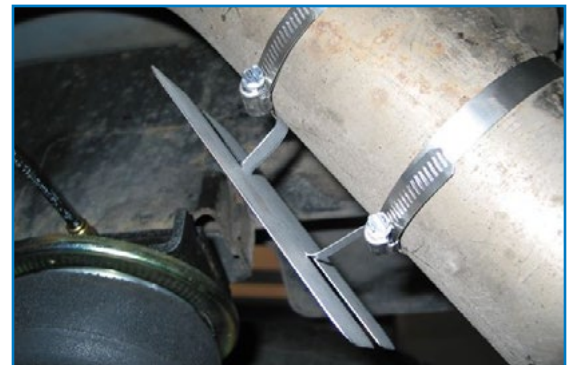

11

**If an in-cab inflation kit is being installed, follow the instructions provided with that kit now.**

### 13 CHECK SYSTEM FOR LEAKS

Inflate both air springs to 90 psi and then use a mixture of dish soap and water on all air line connections to detect any air leaks. Large, expanding bubbles indicate a leak (as shown in Figure 13). Repair as necessary and retest.

Inflate air springs to a predetermined value and on following day recheck pressure. If one or both of air springs have lost pressure, an air leak is present. Leak must be repaired, and then retested until no leaks exist.

### AFTER COMPLETING THE INSTALLATION

#### PLEASE REMEMBER:

Install wheels and torque fasteners to manufacturer's specifications.

Re-torque all fasteners after first 500 miles of driving.

For safe and proper operation, never operate the vehicle under minimum of 10 psi or over maximum of 100 psi in air springs. Staying within pressure limit will ensure maximum air spring life. Failure in doing so may result in a void warranty (see **Note** below).

**NOTE: Do not exceed maximum vehicle payload. Failure to do so may result in failure of the air suspension kit and/or damage to your vehicle.**

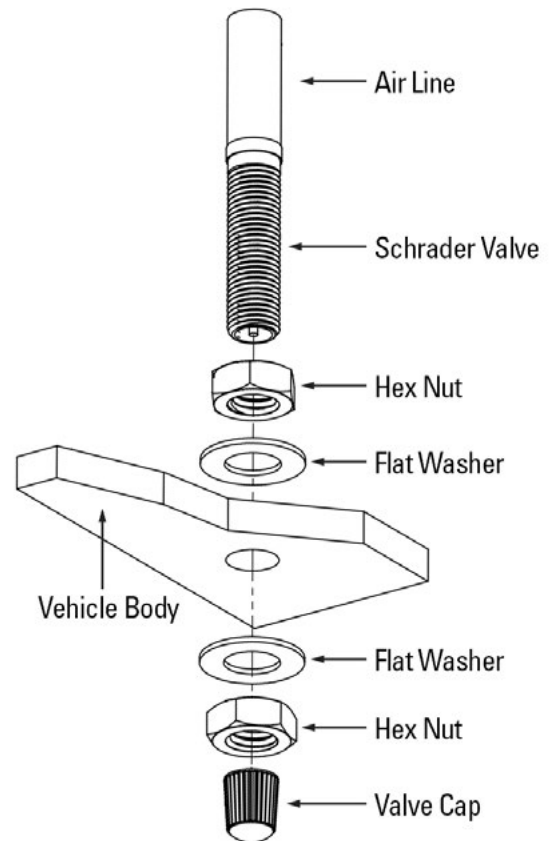

12

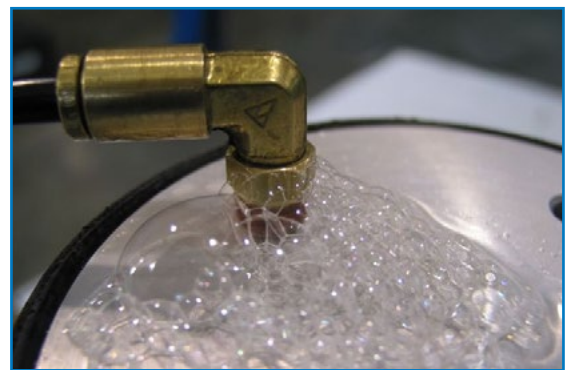

13



***Thank you again, and congratulations on the installation of the air suspension kit.***

### **OPTIONAL ACCESSORIES**

Optional dual needle air gauges are available to monitor pressure in each spring from vehicle cab, as well as a full line of air compressors, air tanks, and solenoids built to work with and control your air spring system.

### **OPERATING YOUR VEHICLE WITH AIR SUSPENSION**

Air springs have minimum and maximum pressure requirements. Never operate your vehicle with less than 10 psi in air spring and never inflate air springs over 100 psi. Damage to air springs will result.

Check air pressure in air springs daily for first couple of days to ensure a leak has not developed. Air springs are designed to maintain the vehicles stock ride height with a load. Do not use the air springs as a means to lift vehicle with no load. This will result in a harsh ride.

### **SERVICING YOUR VEHICLE WITH AIR SUSPENSION**

When lifting the vehicle with a floor jack or hoist on the frame, never allow the air spring to limit the travel of the axle. Try to always jack the vehicle on the axle. Suspending the axle with the air spring limiting the axle travel will damage the air spring and void the air spring warranty.

### **WARRANTY**

To be eligible for warranty, the owner must submit their warranty card or register online within 30 days of the purchase date.

***NOTE: The owner's warranty will be void if air springs are run with less than the minimum of 10 psi.***

