



**DOWNLOAD THE LATEST
INSTALL MANUALS AT
www.bddiesel.com**



BD TorqueShift 6

1064504	2011-2014 6R140 Transmission
1064504SS	2011-2014 Transmission+Converter Package

Table of Contents

Table of Contents.....	2
Introduction.....	2
Important note.....	2
Special Tools.....	2
Removal/Installation.....	3
Removal.....	3
Installation.....	10

Introduction

BD’s performance 6R140 comes with BD’s patent pending locking pressure plates to increase clutch count. This allows BD to increase clutch count without machining OE pressure plates. The transmission includes a BD PressureLoc module, delivering up to 300psi of Line Pressure dependent on engine load.

Important note

If your truck came equipped with an 8 bolt flexplate (2011-Early 2012), you will need to purchase a new 6 bolt flexplate. BD #1041245 or from Ford. Otherwise this transmission will **NOT** fit.

A Ford IDS scan-tool or other capable scan-tool is required for proper installation of this transmission. The scan-tool is used to enter the new solenoid strategy/transmission characteristic code provided with the transmission and initiate a re-learn. Failure to follow these steps will void the warranty.

Special Tools

- Ford tool #307-346 (Optional)
- Ford IDS Scan-tool or another capable scan-tool (Required)

Removal/Installation

Disconnect both vehicle batteries before installation for safety.

Removal

1. With the vehicle in NEUTRAL, position it on a hoist.
2. Remove the transmission fluid level indicator.

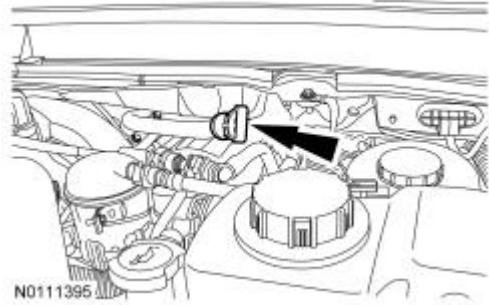

3. Remove and discard the oil filter.

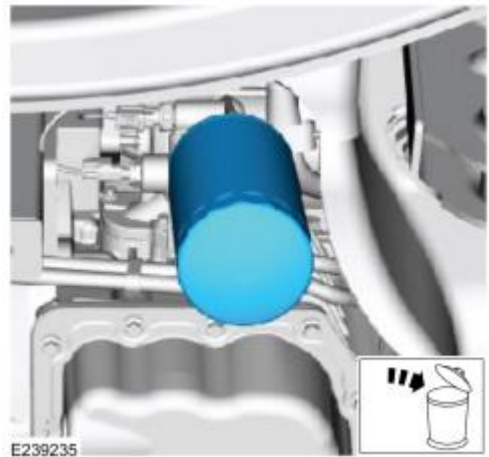

4. Disconnect the oil temperature sensor and oil pressure switch electrical connectors.

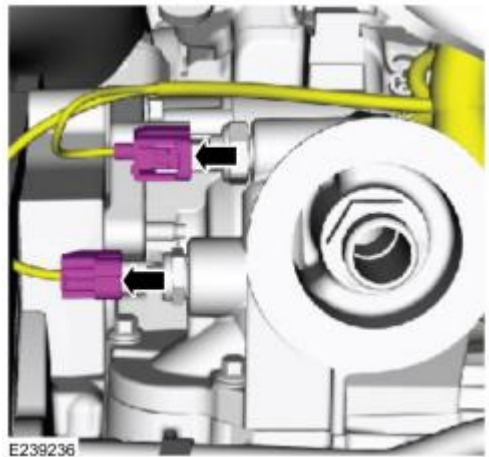

5. Remove the wiring harness bracket nut and position the wiring harness aside.

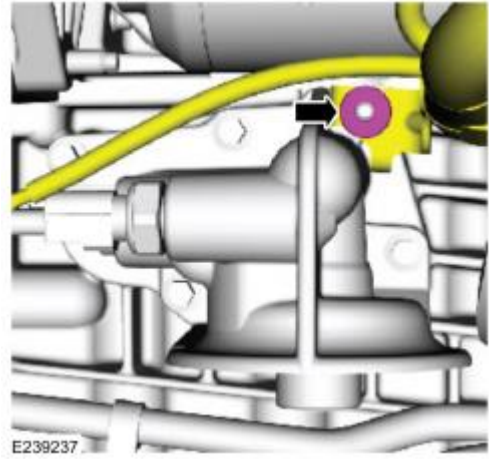

6. Remove the stud bolt, the bolts and the oil filter adapter.

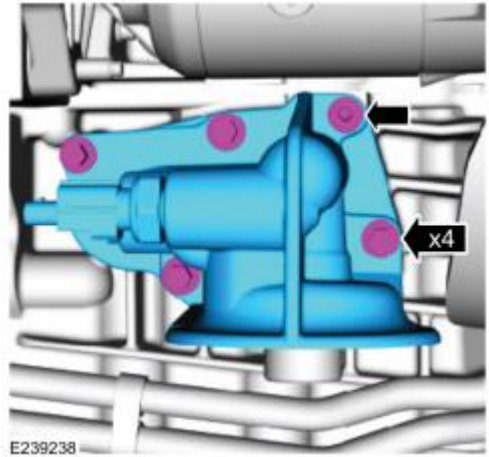

7. Remove and discard the gasket.

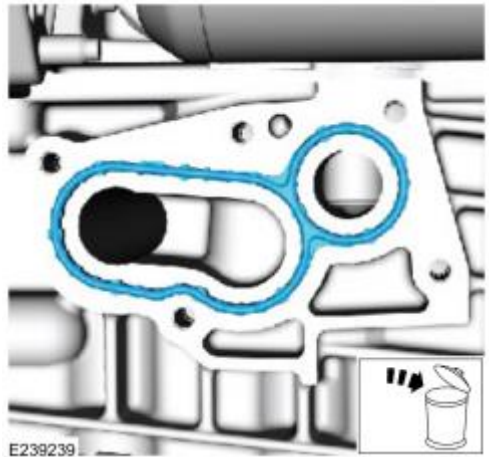

8. Remove the starter motor cable cap.

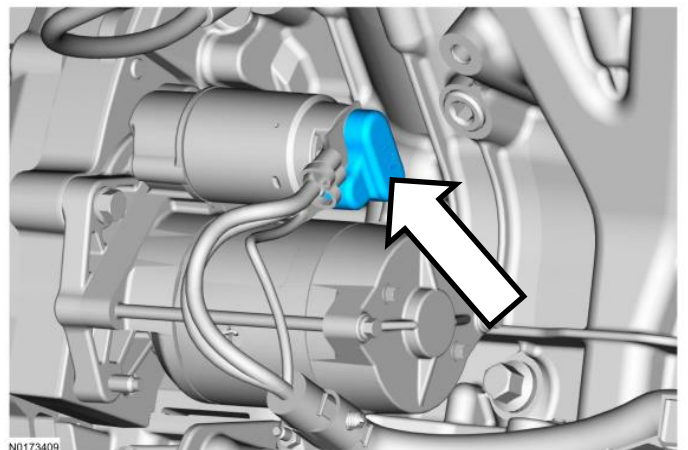

9. Remove the nut and disconnect the starter motor solenoid battery cable.
10. Remove the nut and disconnect the starter motor solenoid control wire.

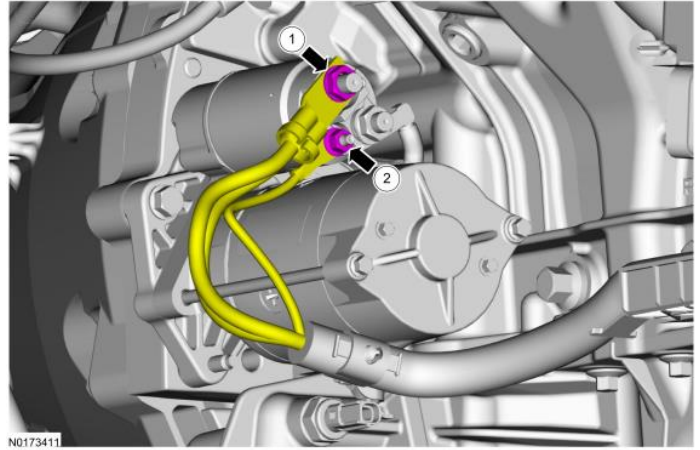

11. Remove the nut and position the wiring harness aside.

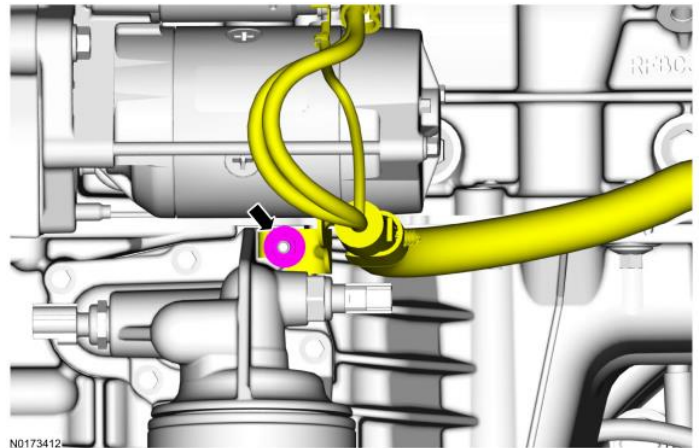

12. If equipped, disconnect the block heater cord.

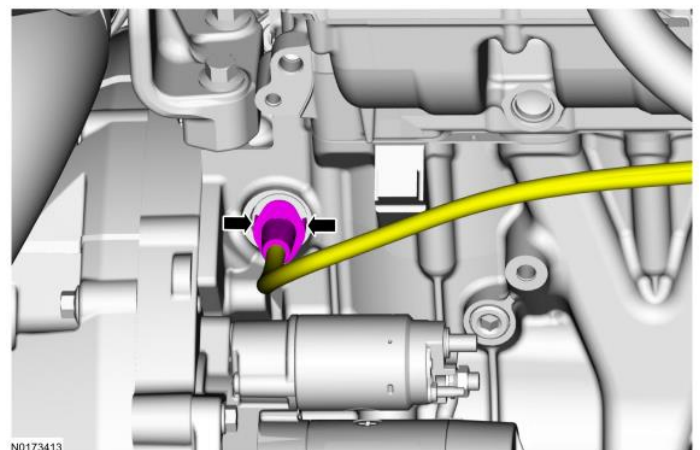

13. Remove the 3 bolts securing the starter and remove the starter.

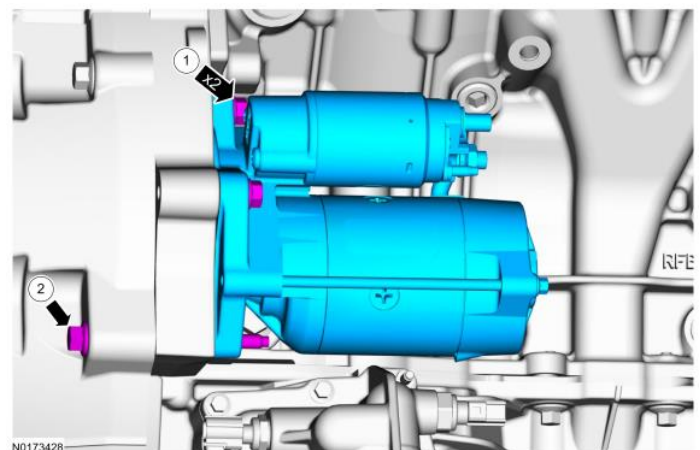

14. Remove the retainers and remove the starter dust shield.

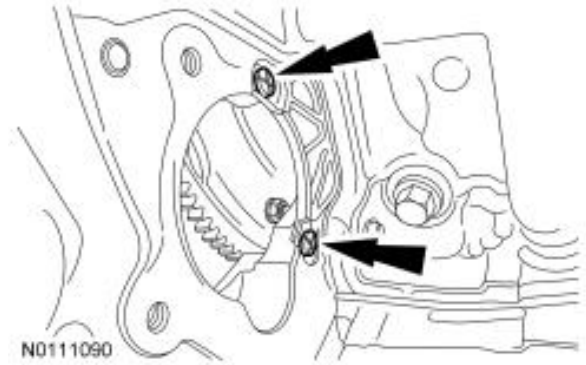

15. Remove and discard the 6 torque converter nuts.
Note: certain models have 8 nuts.

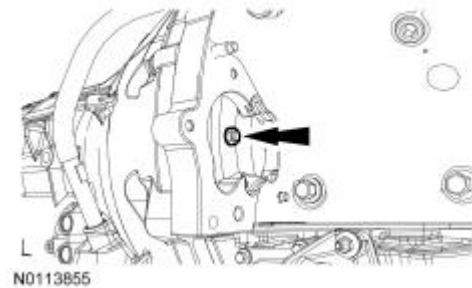

16. Rotate the shell of transmission vehicle harness connector counterclockwise and disconnect the transmission vehicle harness connector.

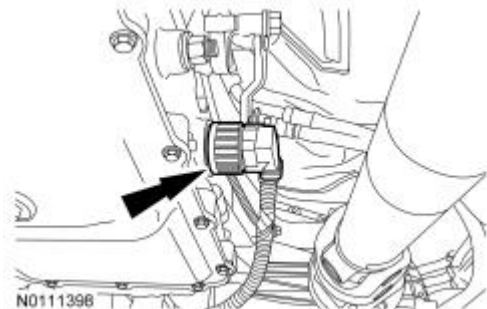

17. Disconnect the selector lever cable end from the manual control lever, remove the 2 bolts and position selector lever cable and bracket aside.

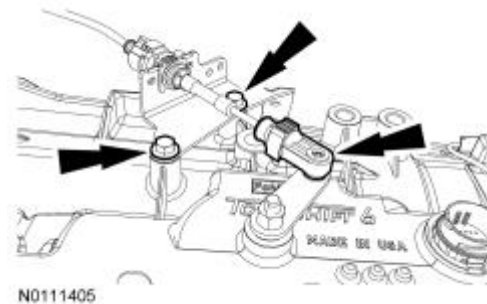

18. Remove the wiring harness retainer from the transmission and position the wiring harness aside.

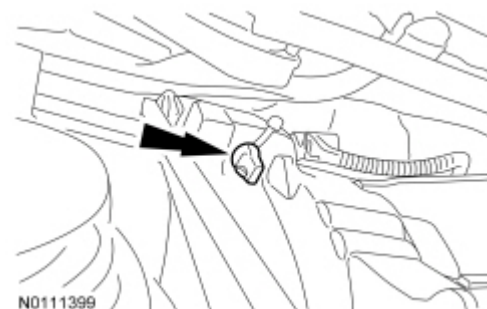

19. Remove the 4 RH engine support insulator nuts.

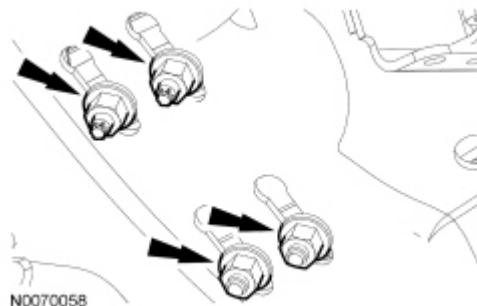

20. Remove the 3 LH engine support insulator nuts.

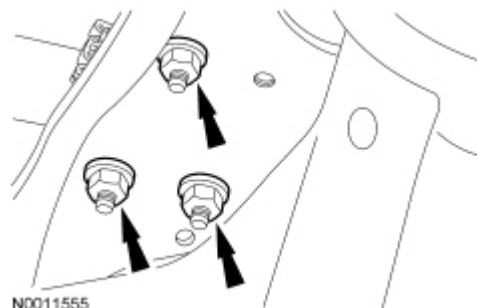

21. Remove the rear driveshaft.
 22. If equipped, remove the 4 bolts and skid plate.
 23. Index mark the front driveshaft and remove the front driveshaft and position aside.

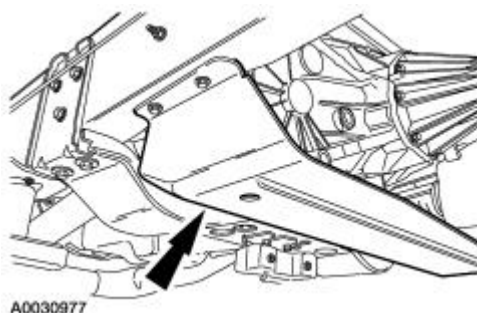

For transmission equipped with a manual shift transfer case follows steps 24-26. Skip ahead otherwise.

24. remove the transfer case linkage bolt and position the transfer case linkage aside.

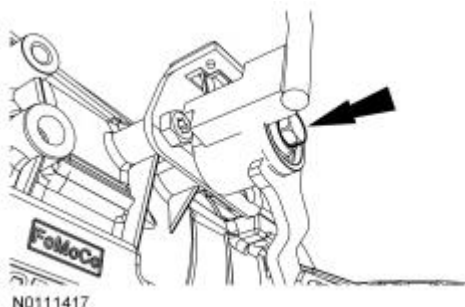

25. Remove the bolt and transfer case linkage bracket.

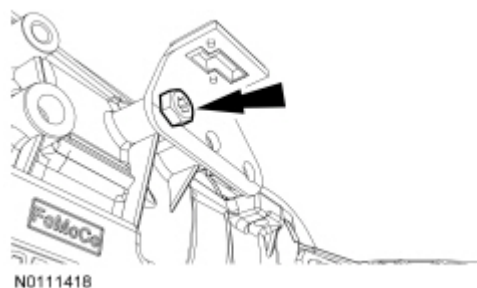

26. Disconnect the 3-position mode switch electrical connector.

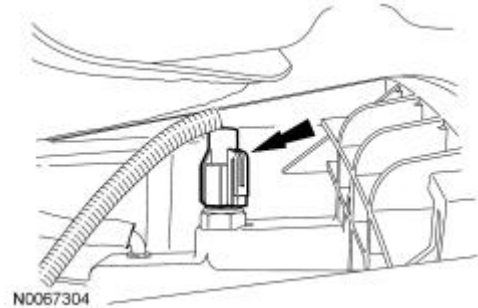

27. For vehicle with electric shift transfer case; disconnect the gearmotor encoder connector and the gearmotor electrical connector.

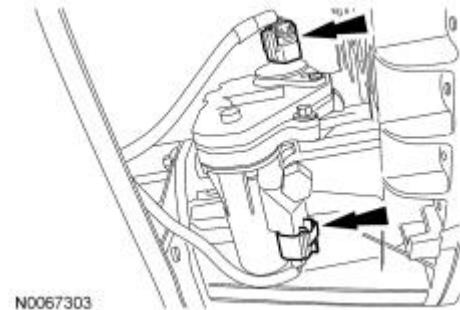

28. Disconnect the vent hose.
 29. Remove the transmission support crossmember.
 30. Position a suitable high-lift jack to transfer case and secure it.
 31. Remove the transfer case bolts. Pull the transfer case rearward and remove from vehicle.



32. Support the transmission with a proper high-lift jack.
 33. Remove the bolt and position the transmission fluid cooler tubes aside.

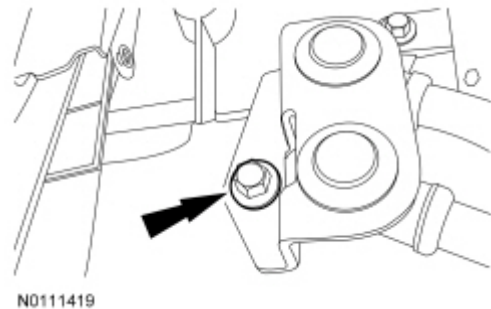

34. Remove the lowers transmission fluid filler tube bolt and position and transmission fluid filler tube aside. Remove and discard the transmission fluid filler tube O-ring.

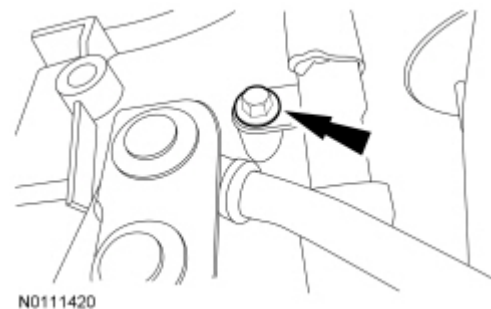

35. Remove the 11 bolts and remove the transmission from the engine dowel pins.



N0111421

36. Slide the transmission back enough to install the Torque Converter Retainer and remove the transmission.

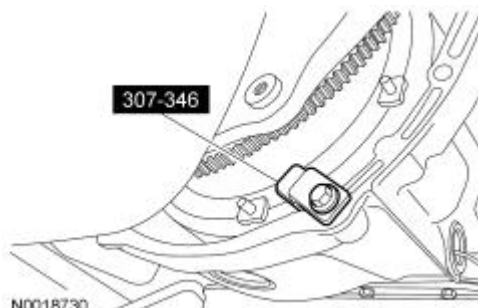

N0018730

Installation

It is highly recommended to clean and backflush the transmission fluid cooler tubes to prevent future repairs.

1. Inspect the back of the engine to be sure both dowel pins are in the engine. If the dowel pins are not in the engine, remove the dowel pins from the previous transmission and reinstall into the engine or install new dowel pins.

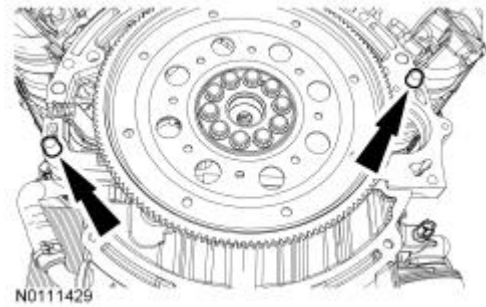

2. Lubricate the torque converter pilot hub with multi-purpose grease and align the paint dot on the torque converter in the 12 o'clock position.

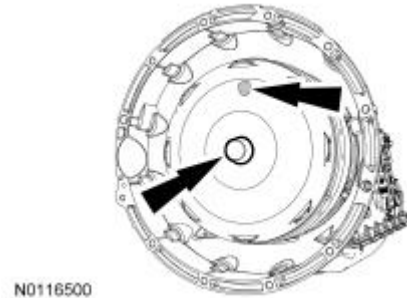

3. Install the Torque Converter Retainer to hold the torque converter in place while moving and positioning the transmission in place. Once the transmission is in place, remove the Torque Converter Retainer.

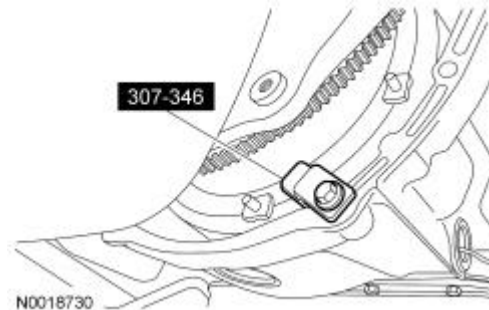

4. Position the transmission on the dowel pins on the back of the engine. Install the 11 bolts. Tighten to 48 Nm (35 ft-lb).

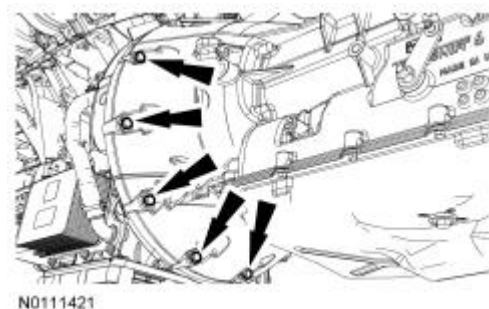

5. Install 6 new torque converter nuts. Tighten to 48 Nm (35 ft-lb).

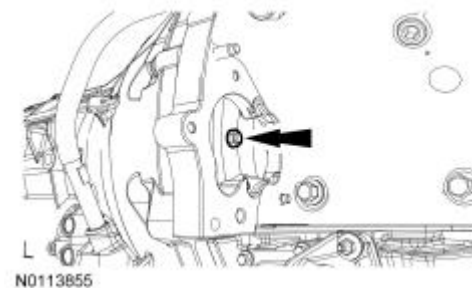

6. Install the starter motor dust shield and install the 2 retainers.

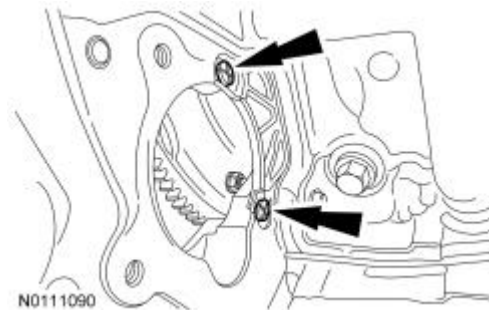

7. Install a new transmission fluid filler tube O-ring. Lubricate it with clean transmission fluid.

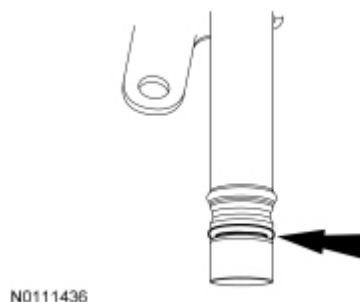

8. Install the transmission fluid filler tube in the transmission and install the lower transmission fluid filler tube bolt. Tighten to 25 Nm (18 ft-lb).

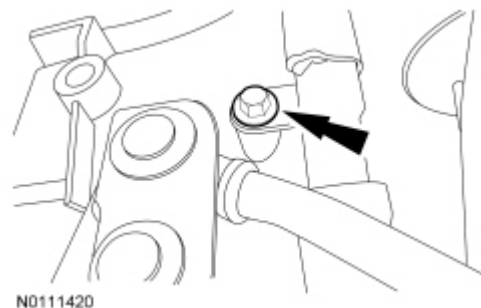

9. Inspect the transmission fluid cooler tube O-rings for damage and install new O-rings as necessary. Lubricate the O-rings with clean transmission fluid.

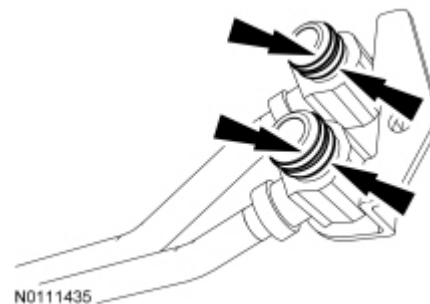

10. Position the transmission fluid cooler tubes in the transmission case and install the bolt. Tighten to 25 Nm (18 ft-lb).

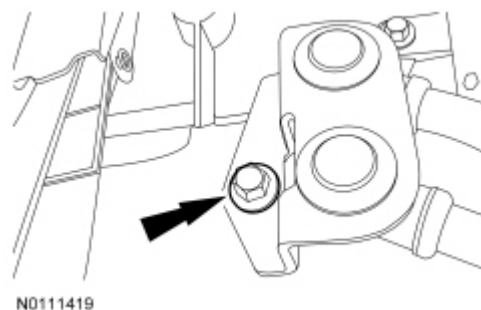

11. Secure the transfer case to a suitable high-lift transmission jack with a safety strap. Position the transfer case to the extension housing.
12. Install the transfer case-to-transmission bolts. Tighten to 55 Nm (40 ft-lb).
13. Lift the transfer case up and install the transmission support crossmember.

14. Vehicles with electric shift transfer case; connect the gearmotor encoder electrical connector and the gearmotor electrical connector.

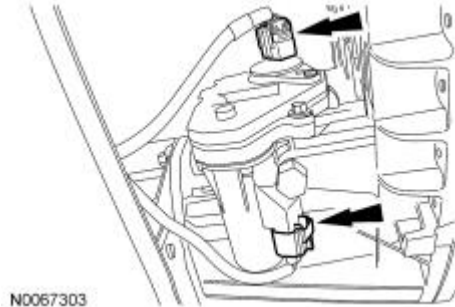

- Vehicles with manual shift transfer case do steps 15-18.
15. Vehicles with manual shift transfer case; connect the manual shift linkage to the transmission.
 16. Connect the 3-position mode switch electrical connector.

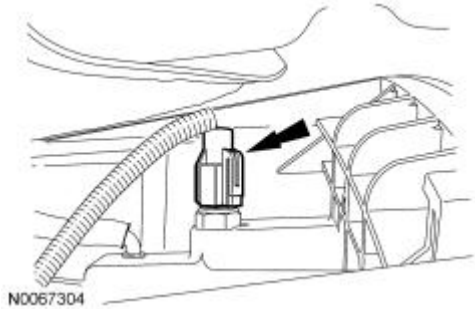

17. Position the transfer case linkage bracket and loosely install the bolt.

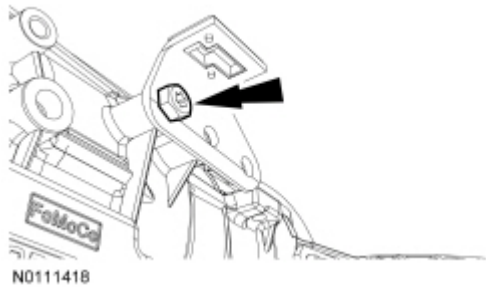

18. Position the transfer case linkage and install the bolt. Tighten to 115 Nm (85 ft-lb).

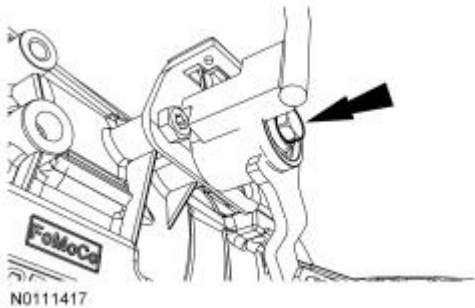

19. Tighten the transfer case linkage bracket bolt to 115 Nm (85 ft-lb).

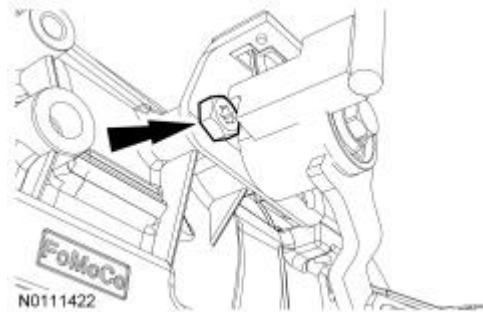

20. Connect the vent hose.
 21. Remove the high-lift jack.
 22. Install the front driveshaft. Be certain to align the index marks made earlier. Tighten to 111 Nm (82 ft-lb).



23. Install driveshaft.
 24. If equipped, install the transfer case skid plate and the 4 bolts. Tighten to 24 Nm (18 ft-lb).

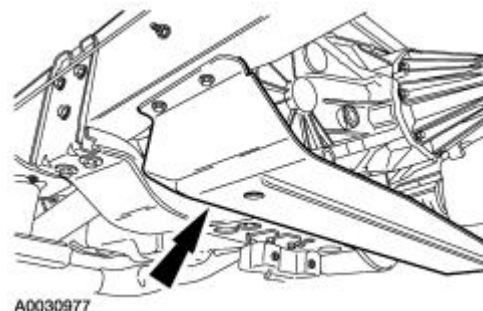

25. Install LH engine support insulator nuts. Tighten to 200 Nm (148 ft-lb).

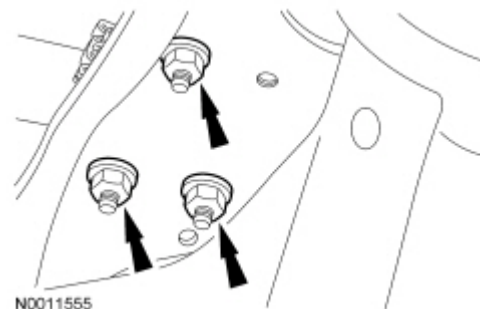

26. Install RH engine support insulator nuts. Tighten to 115 Nm (85 ft-lb).

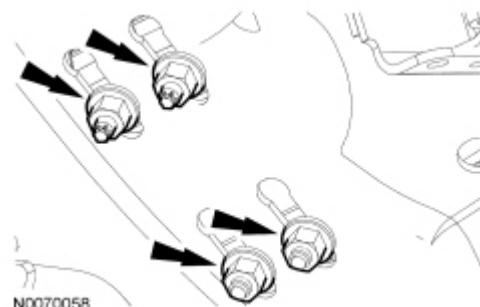

27. Position the wiring harness and install the retainer in the transmission case.

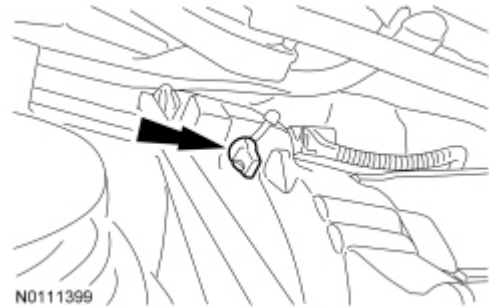

28. Position the selector lever cable bracket and install the 2 bolts. Tighten to 48 Nm (35 ft-lb).

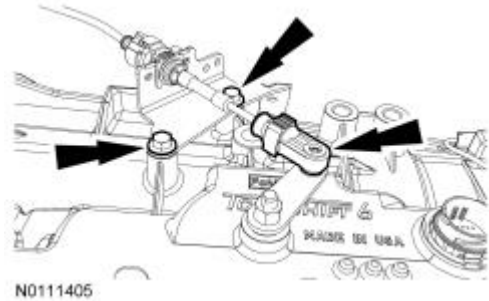

29. Install the transmission vehicle harness connector and lock the transmission vehicle harness connector by rotating the outer shell clockwise.

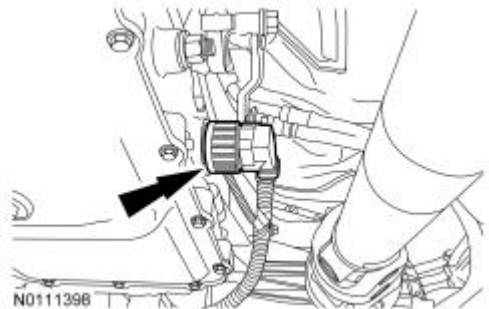

30. Install bolts and tighten to 25 Nm (18 lb-ft).

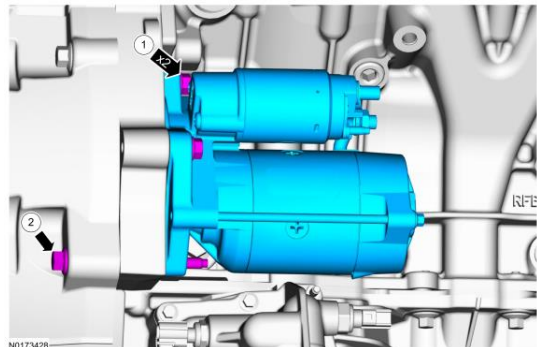

31. If equipped, connect the block heater cord.

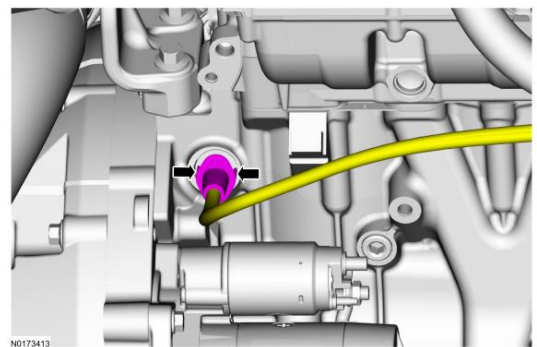

32. Secure the wiring harness and tighten to 12 Nm (106 in-lb).

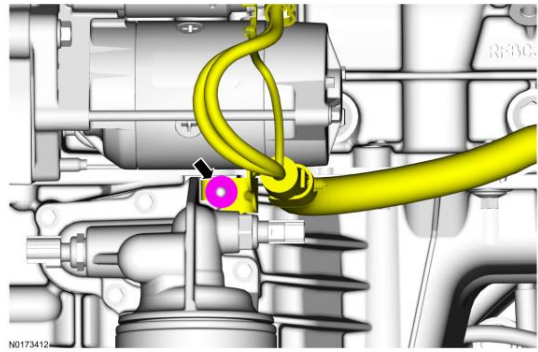

33. Connect the starter motor solenoid control wire (2), Tighten to 5 Nm (44 in-lb)
34. Connect the starter motor battery cable (1). Tighten to 12 Nm (106 in-lb).

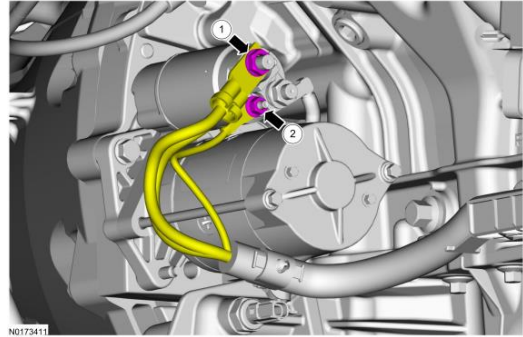

35. Install the starter motor cable cap.

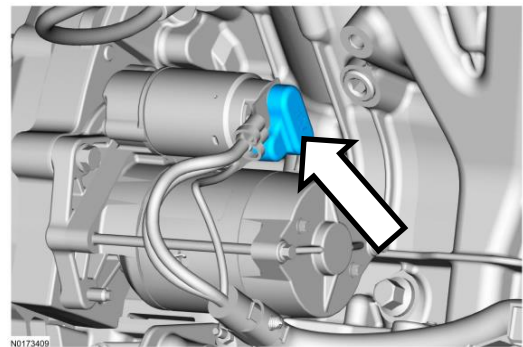

36. Install new gasket.

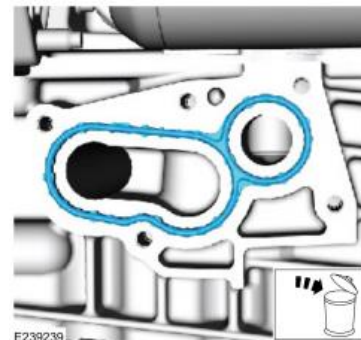

37. Install oil filter adapter and the bolts and stud bolt. Tighten to 12 Nm (106 in-lb)

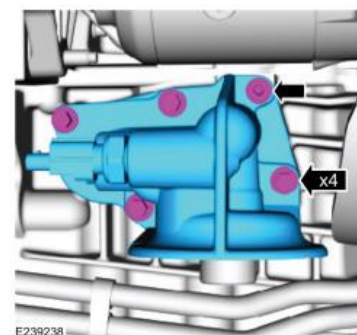

38. Position the wiring harness and install the wiring harness bracket nut. Tighten to 11 Nm (97 in-lb).

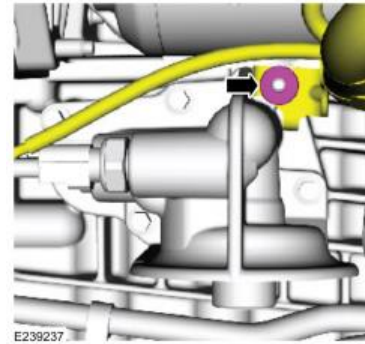

39. Connect the oil temperature sensor and oil pressure switch electrical connectors.

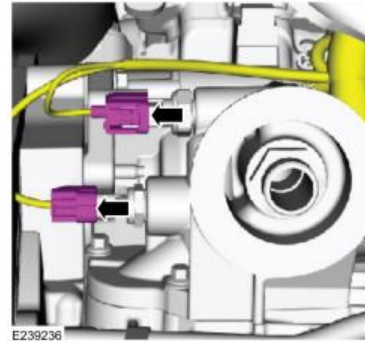

40. Install new oil filter.

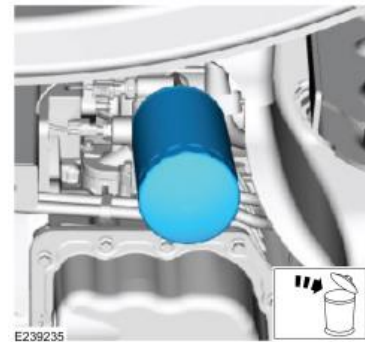

41. Refill transmission with MERCON LV ATF. Check level before starting the truck and cycling through all gear ranges.
42. Connect a Ford IDS or another capable scan-tool and enter the new solenoid strategy/transmission characteristic code.
43. Using the scan-tool, clear the TCM KAM and adaptive table before conducting a solenoid body strategy drive cycle.
44. Drive the vehicle until transmission fluid reaches operating temperature 91°-102°C (196°-216°F). Use scan-tool to verify temperature.
45. Apply the park brake.
46. With the engine running and the brakes applied, move the selector lever in the following sequence pausing between each position for four seconds. Begin in Neutral, N-R-N-D-R-D-N. Repeat this sequence two additional times.
47. Release the park brake and accelerate at moderate throttle so each shift occurs around 1,500 rpm up to 105 km/h (65 mph). Brake moderately to a stop. Repeat this sequence two additional times.
48. Accelerate at moderate throttle so each shift occurs around 2,250 rpm up to 105 km/h (65 mph). Brake moderately to a stop. Repeat this pattern two additional times.
49. Stop the vehicle and apply the park brake.

-
50. With the engine running and the brakes applied, move the selector lever in the following sequence pausing between each position for four seconds. Begin in NEUTRAL, N-R-N-D-R-DN. Repeat this sequence two additional times.
 51. Check level again once at operating temperature and add fluid as necessary.
-