

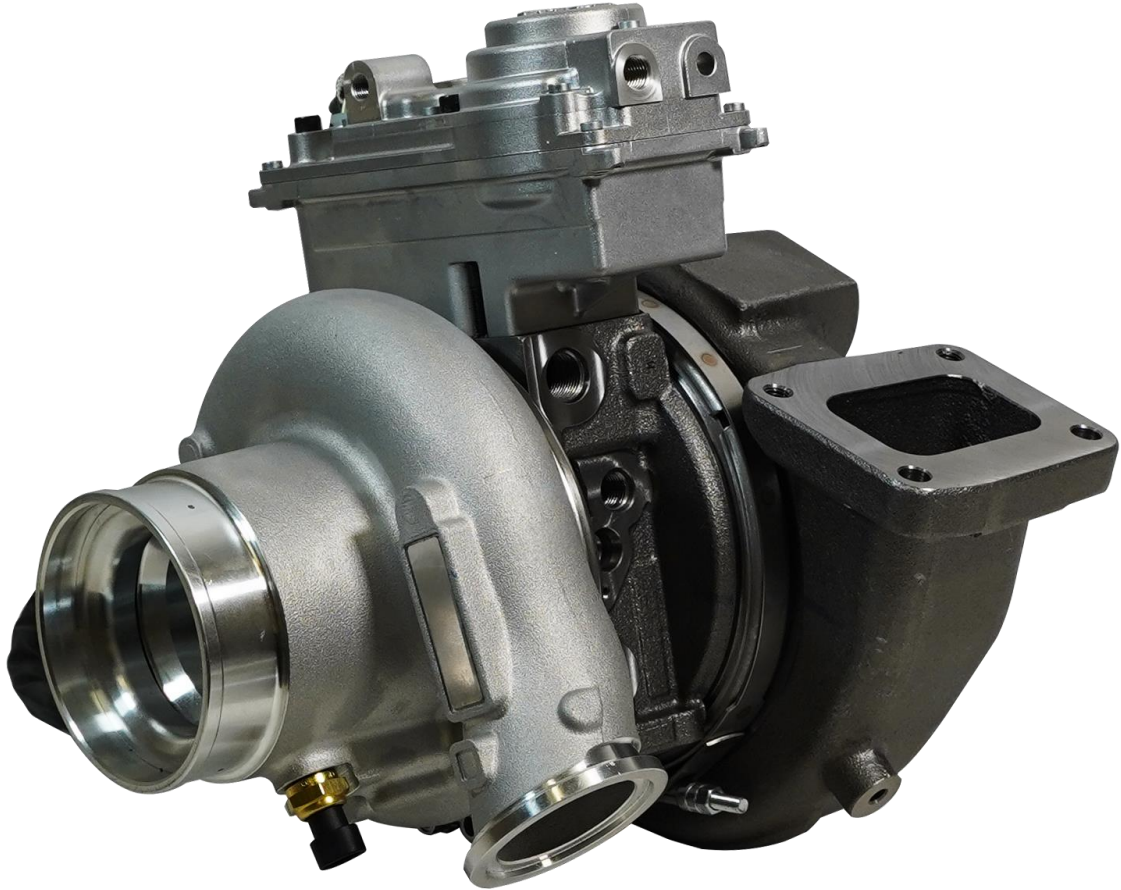





***DOWNLOAD COLOUR  
INSTALL MANUALS AT  
[www.bddiesel.com](http://www.bddiesel.com)***



# **1045880 INSTALL MANUAL HE451VE/HE400VG TURBOCHARGER**

**1045880 HE451VE/HE400VG Turbocharger for ISX15**

## Kit Contents

1045880	2485012	4891288
		
HE451VE/HE400VG Turbocharger	T4 Flange Gasket	Oil Drain Gasket

## Introduction

If turbocharger actuator is removed for any reason, the actuator must be calibrated to the turbo with turbocharger actuator installation procedure. Reinstallation without calibrating turbo actuator may result in a DTC.

This turbocharger has the capability of being clocked in two different ways. From factory it is clocked in the HE451VE (Holset #2882112) orientation. To use the turbo as a HE400VG (Holset #3796351), loosen the v-band on the compressor cover and rotate cover until the stamp marks match. To retain original clocking, align the compressor stamp mark to the speed sensor. Torque the nuts to 160in/lbs.

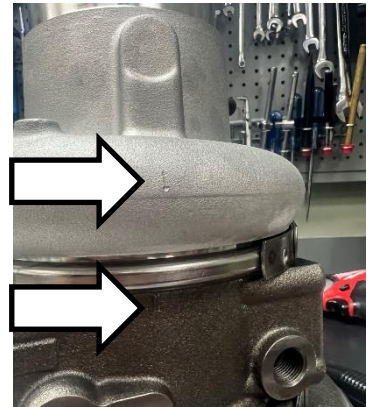

## Tools Required for Installation

- 8mm-21mm Metric Socket and Wrench Set
- Torque Wrench
- Flat Head Screwdriver

## **General Procedure**

1. Inspect the intake and exhaust systems leading to and from the turbocharger to ensure absence of foreign material, including burrs and loose lining fragments.
  - a. Be thorough – even small particles can cause severe rotor damage if inducted during high speed operation.
2. Use new and approved gaskets at the various air, oil and exhaust connections to the turbocharger
  - a. Avoid the use of sealing or jointing compounds at all flanged connections.
3. Use a high temperature anti-seize compound (such as Fel-Pro C5A) on all threaded fasteners connected to the turbocharger.
4. Limit the drain port tilt to 20° from bottom center in either direction.
  - a. Tilting in excess of this amount can create a low-idle leakage tendency at both the turbine and compressor seals.
5. Fill the oil inlet port to overflowing with clean engine oil before connecting the oil feed hose to the turbocharger.
6. If the clamp tabs or V-band are loosened for angular orientation of the compressor cover or turbine housing, be certain that the mating flanges are tightly resealed, and that the fasteners are retightened to the torque levels specified in the appropriate manual.
  - a. Complete the orientation of the cover and housing before making any rigid connections to the compressor inlet and outlet, or to the turbine outlet; this will make certain that all ducting aligns closely with the turbocharger; this will minimize the external stresses acting on the unit.
7. Before connecting the oil drain hose, crank the engine without firing until a steady stream of oil flows from the drain port.
8. Operate the engine at low idle for at least three minutes after completing the installation of any turbocharger. This will prevent oil starvation damage to the bearing system, and will tend to purge any residual contaminants from the bearing housing prior to the unit acceleration.
9. Always change the engine oil and filter when replacing a turbocharger.
10. Replace or clean the air filter.
11. In case of previous failure, inspect CAC for debris. Clean if necessary.

NOTE: Warranty will be denied if the turbocharger is installed on any application not previously approved by BD Diesel Performance.

## ***General Factors Affecting Turbocharger Service Life***

An analysis of turbochargers removed from service indicates that approximately 40% of the troubles are due to foreign material going through either the turbine or the compressor. An additional 40% are due to lubrication failures. The remaining 20% are of a miscellaneous nature.

Come of the foreign material damage is the result of pieces of burned or broken valves and combustion cups going through the exhaust system into the turbine. Other turbine damage is due to casting fins that may break out of the manifolds and ports. Occasionally improperly installed gaskets will permit pieces of gasket to overhang a port and break off into the exhaust system. Damage due to the nuts and washers that are dropped into the exhaust system is also altogether too frequent. Occasionally engine suffer from scuffed and broken pistons. Pieces of these pistons will damage turbine wheels.

Compressor wheel breakage also occurs due to foreign material although not as frequently as turbine wheel damage. Sometimes pieces of the air cleaner will break loose and go through the compressor. There have also been instances where hose connections fail and pieces of rubber or wire reinforcing from the hose gets into the compressor wheel.

Again, carelessness in allowing nuts, bolts and washers to get into the intake system sometimes causes compressor wheel failures.

Lubrication failure may be any one of a number of types. Undersized or plugged oil lines are quite common. It is essential to have an adequate supply of oil at full engine oil pressure for turbocharger bearings. The turbocharger runs at very high speeds and will very quickly overheat with even a momentary failure of oil supply.

The oil supplied to the turbocharger should first pass through a good filter of adequate size so that there is always full oil pressure at the turbocharger bearing. With an adequate supply of clean oil, turbocharger bearing will run for thousands of hours with no measurable wear.

Failure may occur due to extreme exhaust temperatures encountered in excessive altitude operation. Any engine that is operating close to its limits on exhaust temperatures at sea level will have excessive exhaust temperatures when operated at altitudes above 5000 feet.

Altitude operation will cause the turbocharger speed to increase and may cause failures due to over speeding as well as high temperatures unless the engines fuel system is derated according to the manufacturer's recommendations.

Inlet restrictions due to plugged air cleaners, collapsing hose connections, or undersized air pipes have the effect of reducing the air supply to the engine and result in excessive exhaust temperatures. Both inlet restriction and the excessive altitude operation can cause turbine wheel failures due to excess temperatures.

With any turbocharger, it is possible to accumulate enough dirt in compressor housing and diffuser to reduce the airflow capacity and the efficiency of the compressor if air cleaning system is not maintained. Reduced air flow will cause the engine to run hotter and may result in burned valves and pistons which in turn will cause turbocharger failure.

Leaking gaskets or connections on either the intake or exhaust system of the engine will cause a reduction in the air supply to the engine and will result in high exhaust temperatures.

Sometimes air connections and exhaust connections are made in such a manner that thermal expansion of the exhaust manifold and other parts connected to the turbocharger will produce very high loads on the turbocharger. These high loads result in housing distortions that cause the compressor and turbine wheels to rub.

Excessively heaving piping that is supported only by the turbocharger may also cause distortion.

Turbocharger mounting that are not sufficiently rigid to prevent excessive vibrations in the turbocharger can also cause distortions and failures.

In conclusion it can be stated that every few turbocharger failures would occur if no foreign material were permitted to enter either the turbine or the compressor; if precautions were taken to prevent excessive exhaust temperatures, and if the turbocharger were always supplied with an adequate amount of clean oil.

## Cummins Service Bulletin



# Service Bulletin

## Prevention of Turbocharger Damage After Engine Mechanical Issue

### Introduction

This document addresses the possibility of turbocharger damage after the engine mechanical issues. Engine mechanical issues that can put debris into the air handling system (including the exhaust system, exhaust gas recirculation (EGR) system, intake system, and the air intake heater) are rare. They could include piston, intake valve, and exhaust valve issues. However, if **not** properly repaired, these issues can lead to subsequent multiple turbocharger replacements, due to damage from debris that was **not** removed from the air handling system.

### Verification of Issue

#### ⚠ Caution ⚠

All debris must be removed from the air handling system (including the exhaust system, EGR system, intake system, and the intake air heater) after an engine mechanical issue. Failure to remove all debris can lead to turbocharger damage and subsequent multiple turbocharger replacements.

#### ⚠ Caution ⚠

Appropriate engine model Clean Care Kit must be used to prevent debris from entering the air intake system.

**Any of the listed engine types that have had a piston, intake valve, or exhaust valve mechanical issue:**

- All engines with exhaust gas recirculation (EGR) and a variable geometry turbocharger (VGT).

**Symptoms can include those normally present for mechanical issues, such as:**

- Noise
- Vibration
- Running rough

Also, look for multiple turbocharger replacements with Fault Code 2449, Fault Code 1898, Fault code 3616, or Fault Code 2387, and stuck sector gears at very short intervals.

Debris particles as small as 0.70 mm [0.030 in] caught in the air handling system are difficult to clean out. This debris can travel through the EGR system, back into the intake, and out the exhaust manifold to the turbocharger, where it causes damage that prevents motion of the variable geometry turbocharger (VGT) mechanism.

## Resolution of Issue

If an engine experiences a piston, intake valve, or exhaust valve mechanical issue, it is important to understand that the small size of the debris particles could possibly allow them to travel through the air handling system and become lodged in various components (See Figure 1).



Figure 1 – Example of exhaust valve debris

**NOTE:** Some debris pieces are large, however, particles as small as 0.70mm [0.030 in] could damage a turbocharger.

Follow the normal procedures for repair of these types of issues, along with the following additional steps. See Figure 2 through Figure 9 for component locations.

**⚠️ WARNING ⚠️**

When running the engine with turbocharger not installed, keep hands and face away from the exhaust manifold. Wear appropriate eye, face, and hand protection. Flying debris and dirt can cause personal injury.

**⚠️ WARNING ⚠️**

When using solvents, acids, or alkaline materials for cleaning, follow the manufacturer's recommendations for use. Wear goggles and protective clothing to reduce the possibility of personal injury.

**⚠️ WARNING ⚠️**

Some solvents are flammable and toxic. Read the manufacturer's instructions before using.

**⚠️ WARNING ⚠️**

Wear appropriate eye and face protection when using compressed air. Flying debris and dirt can cause personal injury.

1. Replace the EGR cooler.
2. Inspect the interior of the following components. Flush the air passages in the components using safety solvent. Rinse and dry with compressed air. (See Appendix A for component location reference. **Not** all engines are shown)
  - a. All EGR air plumbing
  - b. EGR measurement venturi (ISM and ISX engines)
  - c. Air intake connection (Including intake air heaters where applicable)
  - d. Intake manifold and cover
  - e. Exhaust manifold (for multiple piece manifolds, remove sections and clean)
  - f. Intake and exhaust passages in the head (if the head is to be reused)
  - g. EGR valve
  - h. Charge air cooler (CAC) **must** be cleaned per original equipment manufacturer (OEM) guidelines
3. Operate the engine without the turbocharger installed at low idle for approximately 3-5 minutes to be sure the system is free of debris.

**NOTE:** The following lines need to be blocked off in order to operate the engine without the turbocharger.

- a. Turbocharger coolant supply
- b. Turbocharger coolant return
- c. Turbocharger actuator coolant return
- d. Aftertreatment fuel injector coolant supply (if applicable)
- e. Turbocharger oil supply.

NOTE: Due to the different engine models listed, exact quantities for the plugs and caps are not listed in Table 1 and Table 2. Please refer to the specific engine to determine the type and required number of plugs (Table 1) and caps (Table 2). Actual sizes for the caps and plugs are listed if the Parker™ part is not available. (See Appendix B)

4. After Step 1, 2, and 3 are completed and the engine is assembled with the turbocharger installed, operate the engine at low idle for 2 minutes while deaerating the cooling system. Use low idle for this procedure, to keep the turbocharger speed low while any residual debris is blown out of the system.

## Appendix A

---

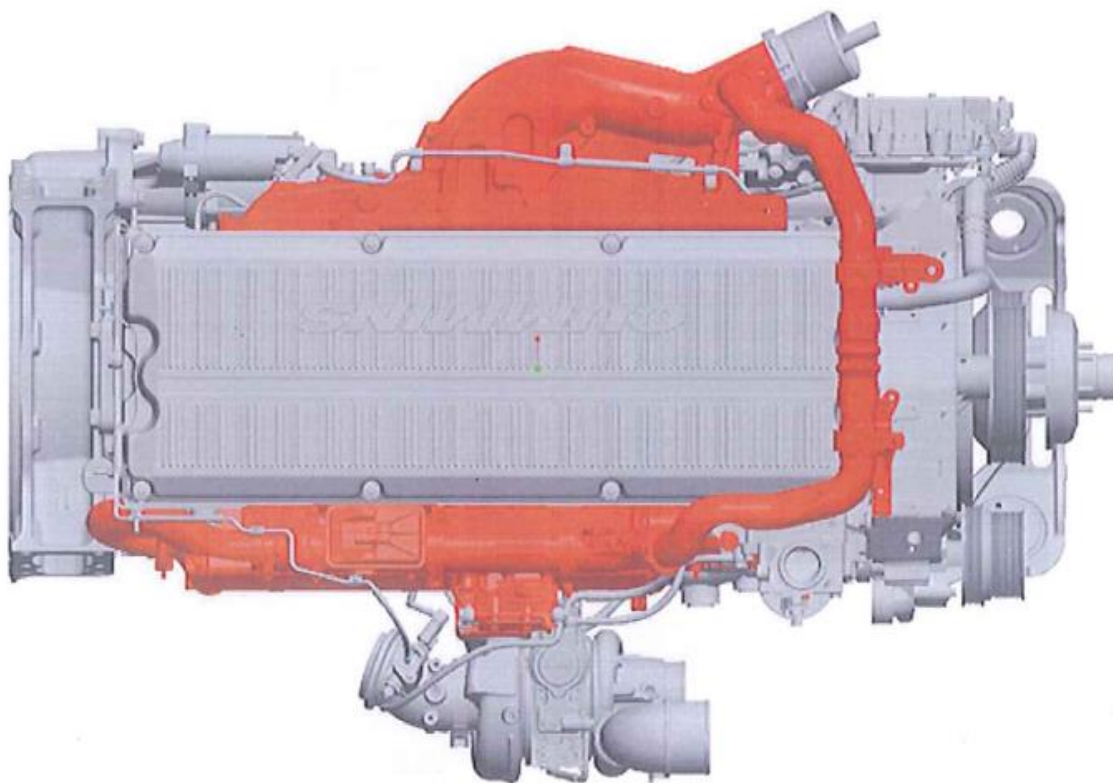

Figure 4 – Components to be inspected and cleaned or replaced are shaded darker. Shown is the ISX15 CM2250/CM2350



## Appendix B

Table 1 lists the required plug sizes for blocking off oil and/or coolant.

©Cummins Inc

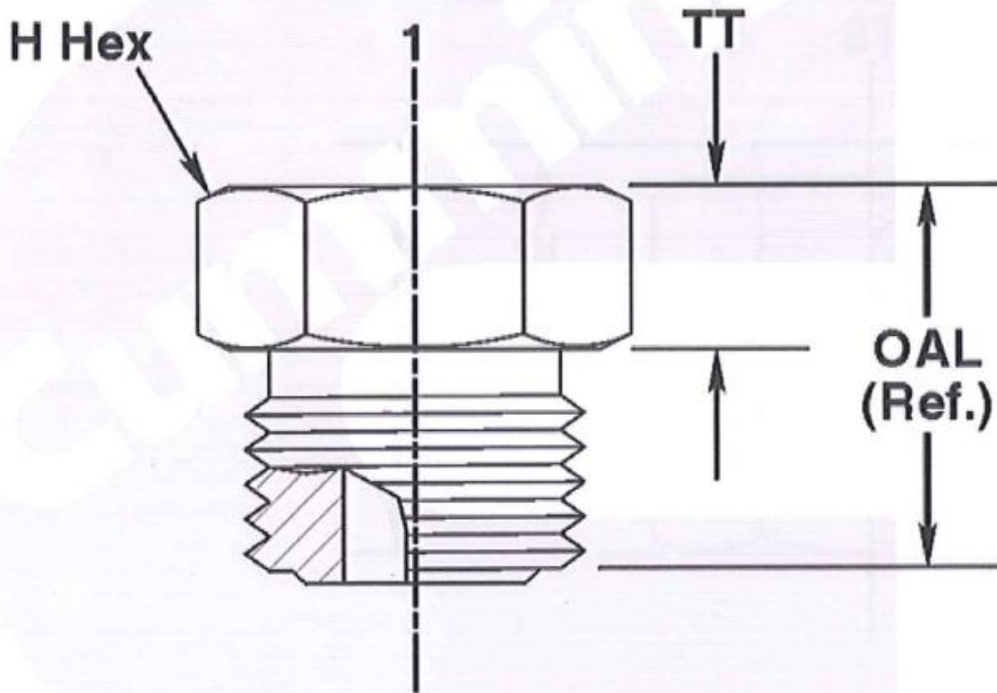

00r00001

O-ring Face Seal Plug dimensions – See Table 1

Table 1 – O-Ring Face Seal Plug				
Parker™ Part Number	Dimension 1 (inch)	Dimension H (inch)	Dimension OAL (inch)	Dimension TT (inch)
6 PNLO	3/8	3/4	0.76	0.32
8 PNLO	1/2	7/8	0.86	0.35

Table 2 lists the required cap sizes for blocking off oil and/or coolant

©Cummins Inc

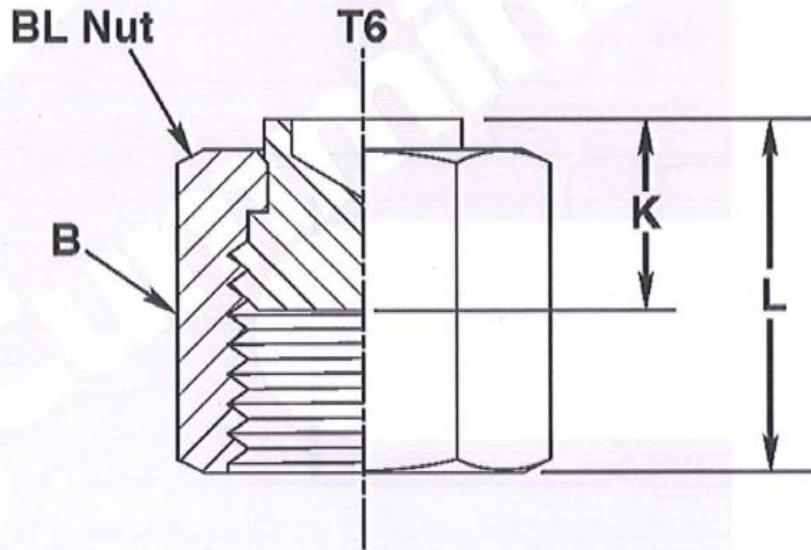

00r00002

O-Ring Face Seal Cap dimensions – See Table 2

Date	Details
2012-9-24	Module Created
2013-10-22	Add qsb6.7 and qsl9 cm2350 engine families
2014-3-4	Corrective Action
2014-9-29	Add QSX15 CM2350
2016-4-4	Updated product affected to a generic statement instead of a specific engine list.

Table 2 – O-Ring Face Seal Cap

Parker™ Part Number	Tube Outside Diameter (OD) (inch)	Dimension T6 (UN/UNF-2B)	Dimension B Hex (inch)	Dimension K (inch)	Dimension L (inch)
4 FNL	¼	9/16-18	11/16	0.34	0.65
6 FNL	3/8	11/16 – 16	13/16	0.39	0.76
8 FNL	½	13/16 – 16	15/16	0.45	0.88