



Owner's Manual with Installation Instructions

Banks Power Pack[®] System

Compatible with Optional Banks iDash

**Including Stinger[®] System
and EconoMind**

**2001-2005 Chevy/GMC 6.6L Duramax
Turbo-Diesel Pickups**

THIS MANUAL IS FOR USE WITH SYSTEMS

48950-48994, 63727, 63728, 63737, 63738, 63713, 63715, 63763, 63765

For iDash 1.8 instructions, see iDash 1.8 manual 97654 & 97674

Gale Banks Engineering
546 Duggan Avenue • Azusa, CA 91702
(626) 969-9600 • Fax (626) 334-1743

Product Information & Sales: (888) 635-4565
Customer Support: (888) 839-5600
Installation Support: (888) 839-2700

bankspower.com



Products Available From Banks Power for the '01-05 Chevy/GMC 6.6L



Big Hoss Intake Manifold System '01-07 (P/N 42733)

- Increases flow and provides more uniform air distribution to the engine for more available power at a given boost level.

Big Head Wastegate Actuator '01-04 (P/N 24396)

- Reaches a higher peak boost faster
- Precise boost control for crisp acceleration and improves midrange pulling power.

Banks Ram-Air Intake System '01-05 (P/N 42132, 42135)

- Increases your airflow over stock.
- Adds power, improves fuel economy, lowers EGTs and reduces smoke.

Banks Super-Scoop '03-07 (P/N 42168, 42169)

- Adds cooler denser air to the Ram-Air Intake housing, further increasing fuel economy, reducing smoke and lowers EGTs.

Banks Techni-Cooler System '01-5 (P/N 25976, 25977, 25978)

- Provides increased air flow to the engine by increasing air density for more increased power, lower EGTs and improved fuel economy.

Banks Diesel Tuner

**'01-05 EconoMind w/ Switch
(P/N 63713, 63715, 63763, 63765)
'01-05 Six-Gun w/ Switch
(P/N 63717, 63767)**

- Adds power safely to your vehicle
- Engine and transmission safeguards
- Change power levels on-the-fly

**Banks Speed-Loader
'01-07 (P/N 63718)**

- Furthers the power output of the Banks Six-Gun and provides EGT limiting safety.

Thermocouple

- Add a temperature limiting function to your diesel tuner.

Banks Brake

'01-05 (P/N 55232, 55233, 55447)

- All electronic brake, no cutting pipes.
- Allows for varied braking intensity based on switch position.
- Setting to turn ON with use of your vehicle brake pedal to aid braking

Banks SpeedBrake

'04-05 (P/N 55437, 55440)

- Everything the **Banks Brake** does
- Allows for controlled hill decent at a user defined or preset vehicle speed.

**Banks AutoMind Programmer
(P/N 66104)**

- Clear and view OBDII Diagnostic Trouble Codes (DTC).
- Loaded with dyno-proven tuning files
- Speed Limiter adjustment capabilities
- Recalibration of the speedometer
- Customize and adjust gearing, tire size and fuel octane

**Banks Billet Torque Converter
'01-09 (P/N 72510)**

- Higher torque capacity over stock
- Lockup clutch is slip-resistant so transmission fluids stay cooler and transmission life is prolonged.

**Boost and Pyro Gauges
'01-06 (P/N 64507)**

- Keep your engine safe by monitoring vital engine parameters

**For More Information please call 1-800-635-4565
or Visit us online @ www.bankspower.com**

General Installation Practices

Dear Customer, if you have any questions concerning the installation of your Banks PowerPack system, please call our Technical Service Hotline at (888) 839-2700 between 7:00 am and 4:00 pm (PT). If you have any questions relating to shipping or billing, please contact our Customer Service Department at (888) 839-5600.

Thank you.

1. For ease of installation of your Banks system, familiarize yourself with the procedure by reading the entire manual before starting work.
2. The exploded illustrations provide only general guidance. Refer to each step and section diagram in this manual for proper instruction.
3. Throughout this manual, the left side of the vehicle refers to the driver's side, and the right-side to the passenger's side.

4. Disconnect the ground cable from the battery before beginning work. If there are two batteries, disconnect both.
5. Route and tie wires and hoses a minimum of 6 inches away from exhaust heat, moving parts and sharp edges. Clearance of 8 inches or more is recommended where possible.
6. During installation, keep the work area clean. If foreign debris is transferred to any Banks system component, clean it thoroughly before installing.
7. When raising the vehicle, support it on properly weight-rated safety stands, ramps or a commercial hoist. Follow the manufacturer's safety precautions. Take care to balance the vehicle to prevent it from slipping or falling. When using ramps, be sure the front wheels are centered squarely on the topsides; put the transmission in park; set the parking brake; and place blocks behind the rear wheels.

Caution! Do not use floor jacks to support the vehicle while working under it. Do not raise the vehicle onto concrete blocks, masonry or any other item not intended specifically for this use.

General Assembly Diagram BANKS POWER PACK SYSTEM

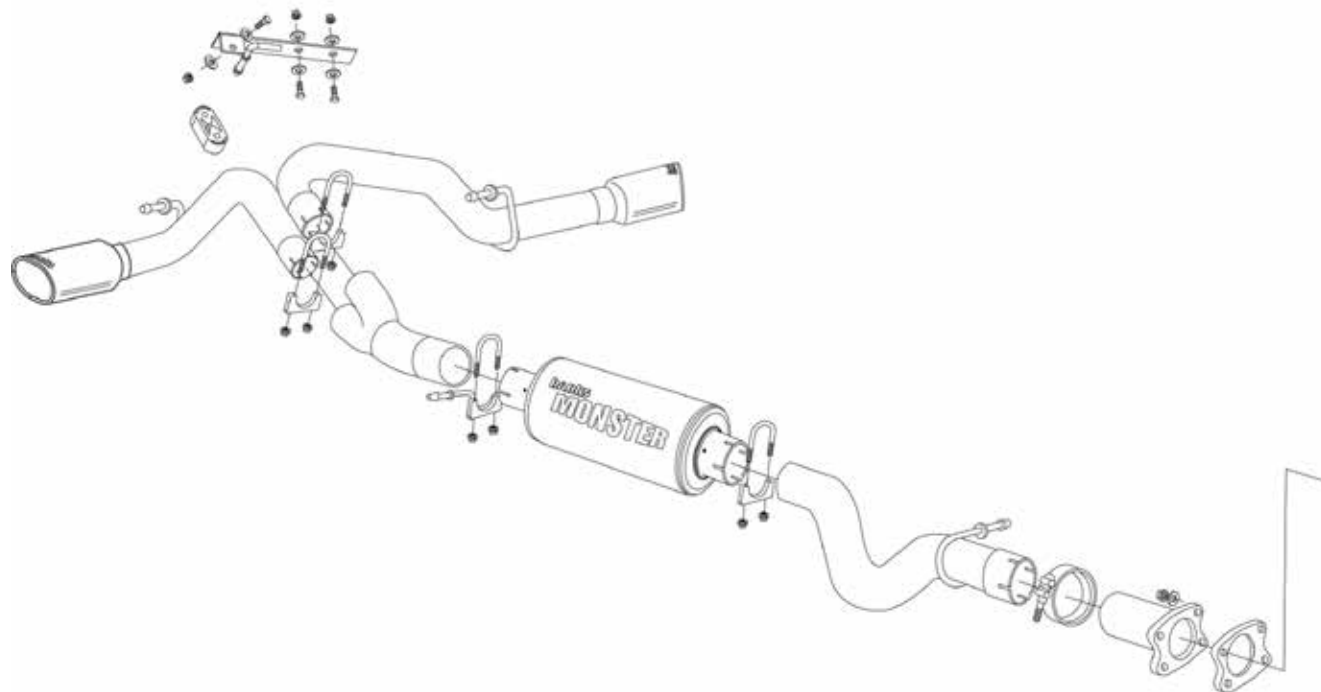

Tools Required:

- 1/4" and 3/8" drive ratchets
- Inch and metric deep sockets
- Ratchet extension
- Metric combination or open-end wrenches
- Phillips and flat blade screwdrivers
- Standard and needle-nose pliers
- Pocket or X-Acto knife
- Clean shop towels or rags
- Drill bit set
- Drill motor
- Tap Handle
- 1/4" NPT tap
- 5/16 nut driver
- Pliers
- Torx bits
- Pry-bar

Highly recommended tools and supplies:

- Multimeter or 12-volt test light
- Heat gun
- Foot-pound torque wrench
- Penetrating oil or light lubricant spray
- Reciprocating saw
- Inch-pound torque wrench

Notification

The Banks Ram-Air Filter comes pre-oiled and no oiling is necessary for initial installation. Service the filter as specified in the Filter maintenance Section of this manual.

Table of Contents

General Assembly Diagram	4
Banks Power Pack System	
Section 1	6
Installation of Banks Monster Exhaust System	
Section 2	13
Techni-Cooler Assembly Installation	
Section 3	19
Thermocouple Installation	
Section 4	20
Banks Ram-Air Intake System	
Section 5	25
Banks EconoMind Diesel Tuner Installation	
Section 6	27
Mounting & Connecting the Banks iDash	
Section 7	29
Installation of the Power Level Selector Switch	
Section 8	30
Optional Gauge Cluster Installation	
Section 9	31
Automatic Transmission Learning	
Section 10	32
Troubleshooting, EconoMind	
Section 11	34
Clearing Learned Parameters	
Section 12	34
Removal of the EconoMind Diesel Tuner	
Section 13	35
Filter Maintenance	
Section 14	36
Placement of the Banks Power Decals	

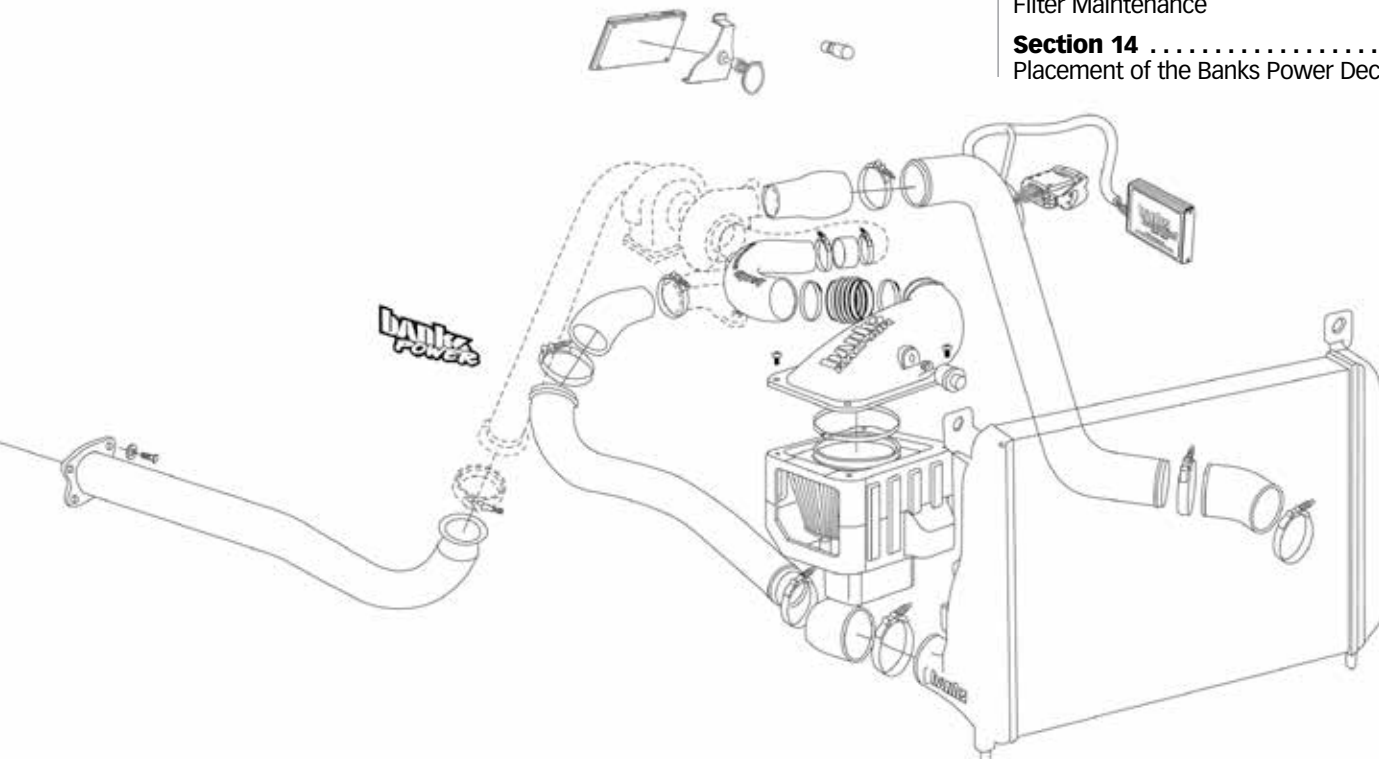

Section 1

INSTALLATION OF BANKS MONSTER EXHAUST SYSTEM

Figure 1a
General Assembly
Banks Monster Exhaust (Single Tailpipe)

Description	Part #	Qty.
1 Monster muffler		
Ext./Crew Cab Short Bed/Std Cab Long Bed	53800	1
Ext./Crew Cab Long Bed	53801	1
2 Intermediate pipe		
Standard Cab Long Bed	53718	1
Ext./Crew Cab Short Bed	53719	1
Ext./Crew Cab Long Bed	53720	1
3 Tailpipe (2-pieces)		
Front, Tailpipe (SCLB-EC/CCSB)	53710	1*
Rear, Tailpipe (SCLB-EC/CCSB)	53711	1
Front, Tailpipe (CCLB)	53728	1*
4 Flanged intermediate pipe		
Standard Cab Long Bed (SCLB)	53713	1
Ext./Crew Cab Short Bed/Ext./Crew Cab Long Bed	53717	1
5 Polished 5-inch exhaust tip with clamp	52383	1
6 4" Exhaust hanger/clamp (saddle type)		
Ext./Crew Cab Long Bed	53707	1
7 4" Band clamp	52471	1
8 4" Exhaust clamps (saddle type)	52470	3**
9 Exhaust gasket	93210	1
10 Head pipe assembly (non-cat models)	53716	1
11 7/16-20 x 1.5" bolts (non-cat models)	91629	4
12 7/16-20 Crimplock nuts (non-cat models)	91619	4
13 7/16 AN washers (non-cat models)	91601	8

* P/N 53728 is used in place of 53710 when vehicle is (Crew Cab Long Bed) CCLB

**Ext./Crew Cab Long Bed only receive (2)

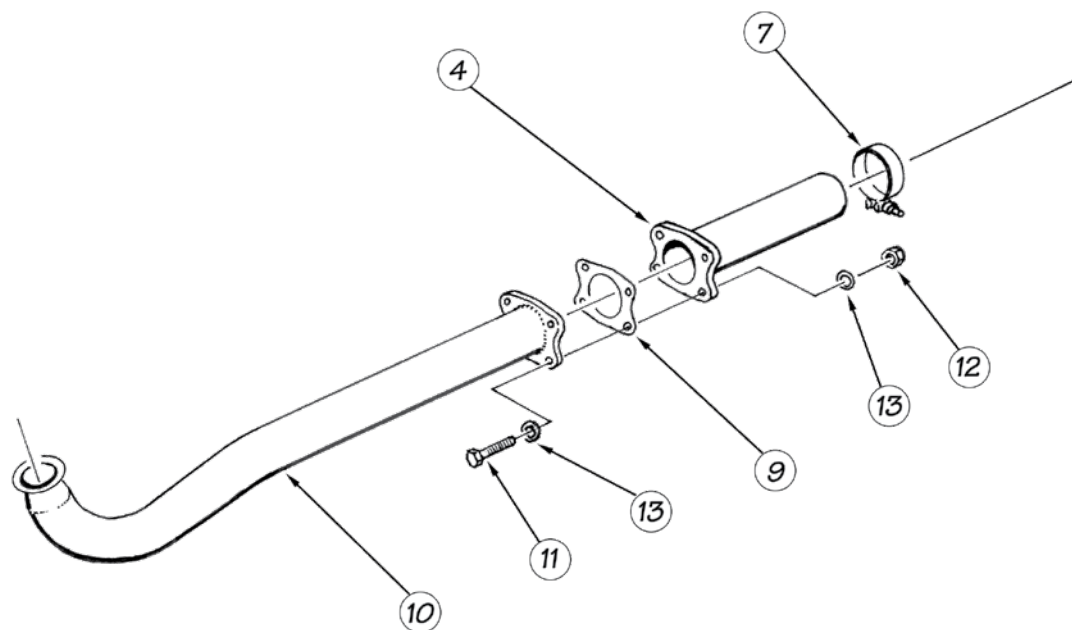

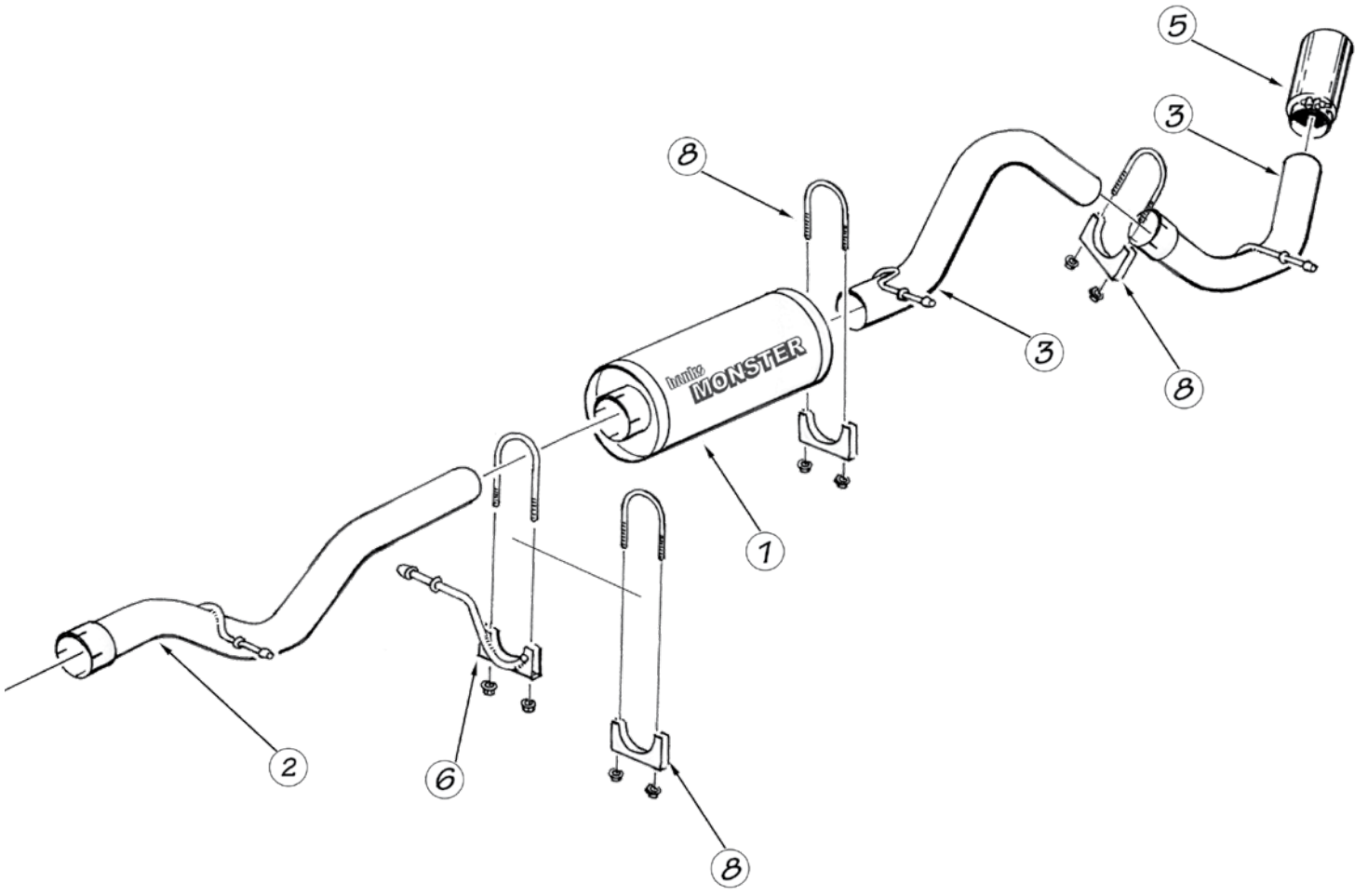
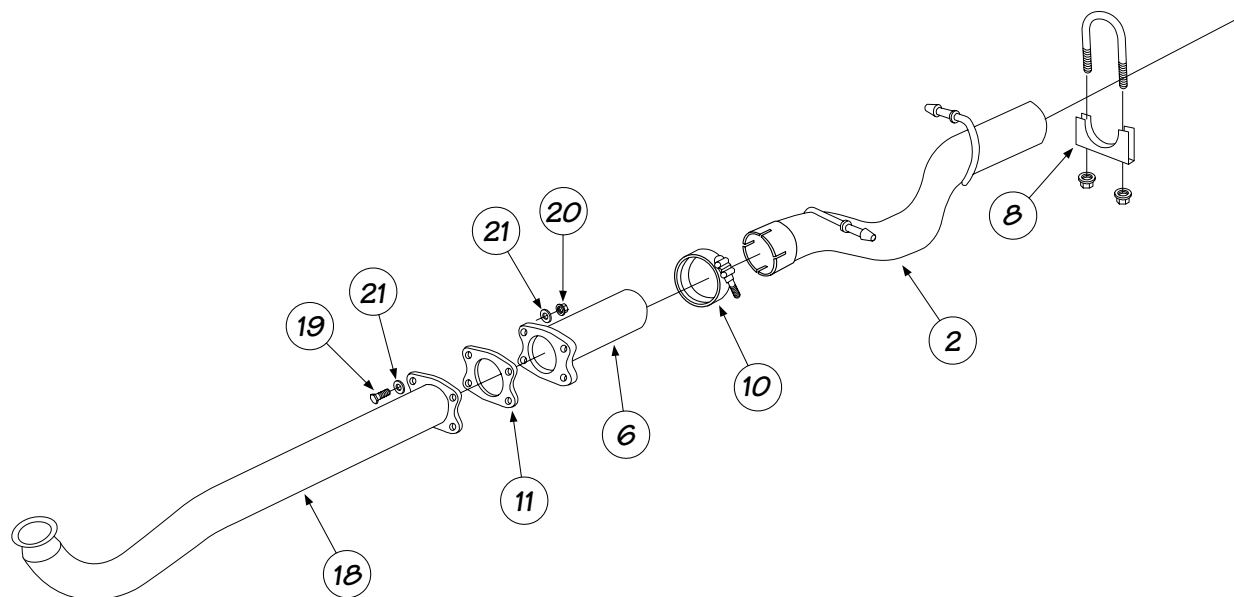
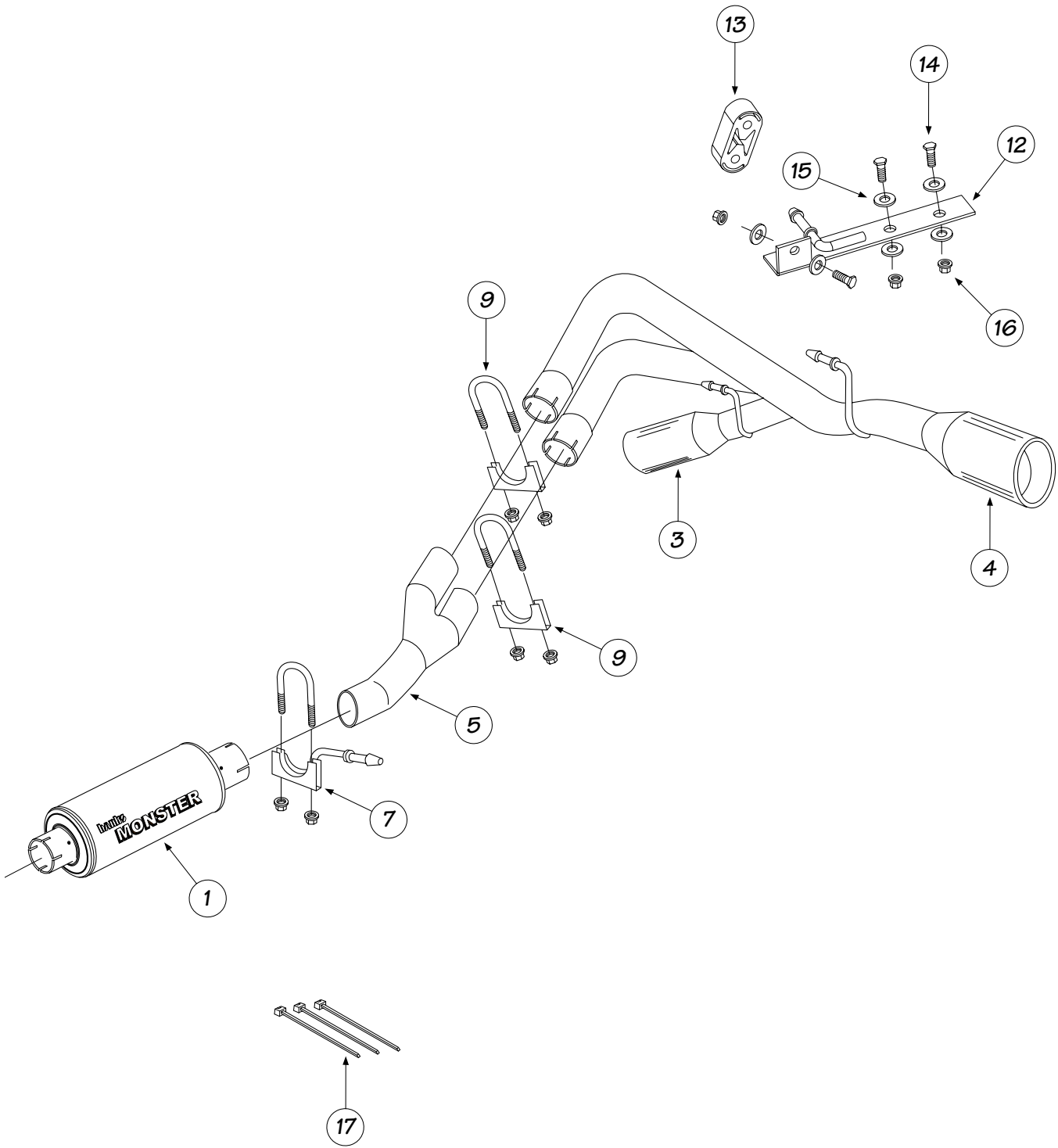

Figure 1b
 General Assembly
Banks Split-Dual Monster Exhaust, Split-Dual

Description	Part #	Qty.
1 Monster muffler	53800	1
2 Intermediate pipe		
Standard Cab Long Bed	53721	1
Ext. Crew Cab Short Bed/Crew Cab Short Bed	53724	1
Ext. Crew Cab Long Bed/Crew Cab Long Bed	53725	1
3 Passenger side tailpipe	53743	1
4 Driver side tailpipe	53744	1
5 Y-pipe, Split dual	53727	1
6 Flanged Intermediate extension pipe		
Standard Cab Short Bed/Ext. Crew Cab Short Bed/Crew Cab Long Bed/Crew Cab Short Bed	53717	1
Standard Cab Long Bed	53713	1
7 Rear muffler hanger/clamp	53726	1
8 4" Saddle clamp	52476	1
9 3.5" Saddle clamp	52467	2
10 4" Band clamp	52471	1
11 4-bolt gasket	93210	1
12 Driver side frame hanger bracket	53731	1
13 Driver side rubber insulator	53732	1
14 1/2-13 x 1.0" Bolt	91930	2
15 1/2 SAE washer	91902	4
16 1/2-13 Nylock nut	91823	2
17 5" Black cable tie	62001	3
18 Head pipe assembly (non-cat models)	53716	1
19 7/16-20 x 1.5" bolts (non-cat models)	91629	4
20 7/16-20 Crimplock nuts (non-cat models)	91619	4
21 7/16 AN washers (non-cat models)	91601	8





EXHAUST SYSTEM INSTALLATION

Use the Bill of Materials Chart and **Figure 1a** or **1b** to reference component nomenclature and location. Use caution when working in the engine compartment. Make sure the engine has been OFF for several hours and cool.

1. Disconnect the ground of the battery (if there is more than one battery, disconnect both).
2. Raise the vehicle and support it with properly weight rated safety stands, ramps or a commercial hoist. Follow the manufacturer's safety precautions. Take care to balance the vehicle to prevent it from slipping or falling. When using ramps, be sure the front wheels are centered squarely on the topsides; place the transmission in park; set the parking brake and place blocks behind the rear wheels.

CAUTION: DO NOT WORK UNDER ANY VEHICLE SUPPORTED ONLY BY A JACK. SEVERE INJURY MAY RESULT.

CAUTION: The following step involves cutting a stainless steel tube. Safety glasses should be worn during any cutting operation and care should be taken to avoid injury due to sharp edges and burrs.

3. Removal of the factory exhaust can be simplified by cutting the factory exhaust pipe behind the muffler. This will allow the tailpipe to be removed as a separate piece.
4. Remove the four (4) nuts from the factory exhaust flange located at the back side of the factory head pipe (retain for re-use).
5. Remove the factory tailpipe from the vehicle by disengaging the exhaust system hanger pins from the rubber grommets using a large screw-driver or pry bar.
Note: Lubricating the rubber hangers with WD-40 or similar lubricant will ease removal of the hanger pins.
6. Remove the factory muffler from the vehicle by disengaging the hanger pins from the rubber grommets using a large screwdriver or pry bar.
- Step 7 thru 10 for vehicles with no catalytic converters only.**
7. Spray penetrating oil such as WD-40 on the T-bolt of the factor V-band clamp

Figure 2

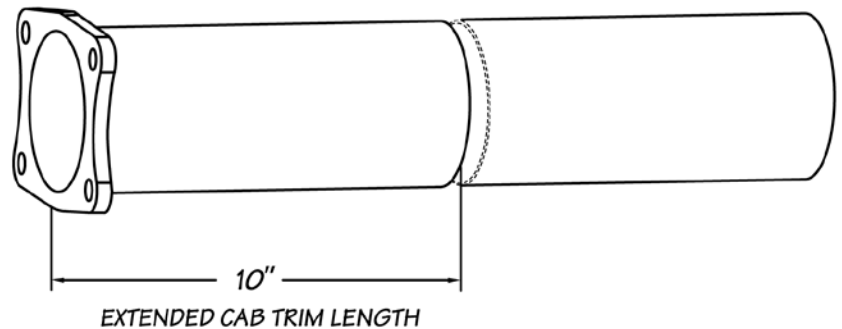
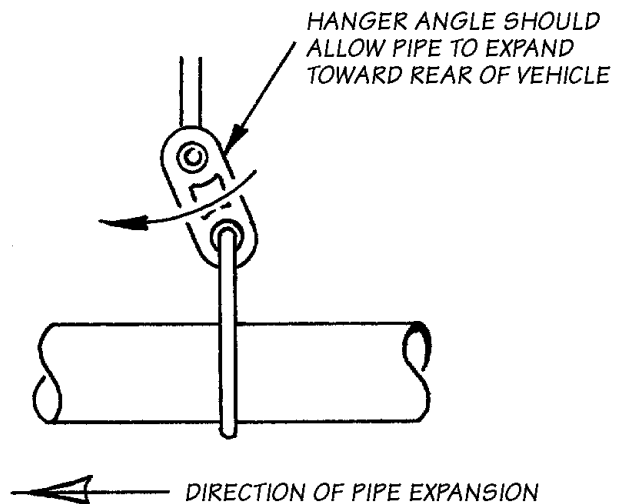

Figure 3



to prevent galling. Remove factory V-band clamp and save for re-use.

8. Remove factory head pipe from the vehicle by disengaging the exhaust system hanger pins from the rubber hangers using a large screwdriver or pry bar.
9. Install Banks head pipe in vehicle and insert the hanger pin in the rubber exhaust hanger.

NOTE: Be sure to install the hanger pin in the same location as the previously removed factory head pipe.

10. Loosely install V-band clamp on head pipe flange and only tighten the T-bolt on the clamp to the point that the pipe is snug but can still be rotated in the clamp for adjustment/alignment.

NOTE: Do not completely tighten the V-band clamp at this point.

11. If the system is being installed on an extended-cab vehicle, the Banks flanged intermediate pipe (53717) must be trimmed prior to installation in the vehicle. For extended-cab models, trim 9-1/2" from the outlet of the intermediate pipe such that 10" including the flange is remaining. Once the cut has been performed, debur the cut end with a file or sandpaper. (See **Figure 2**).

12. Install the Banks flanged intermediate pipe and 4-bolt gasket onto the headpipe. Loosely assemble with the four (4) factory nuts. Slide the Banks 4-inch band clamp on the outlet of the Banks 4-bolt flange pipe.

Figure 4

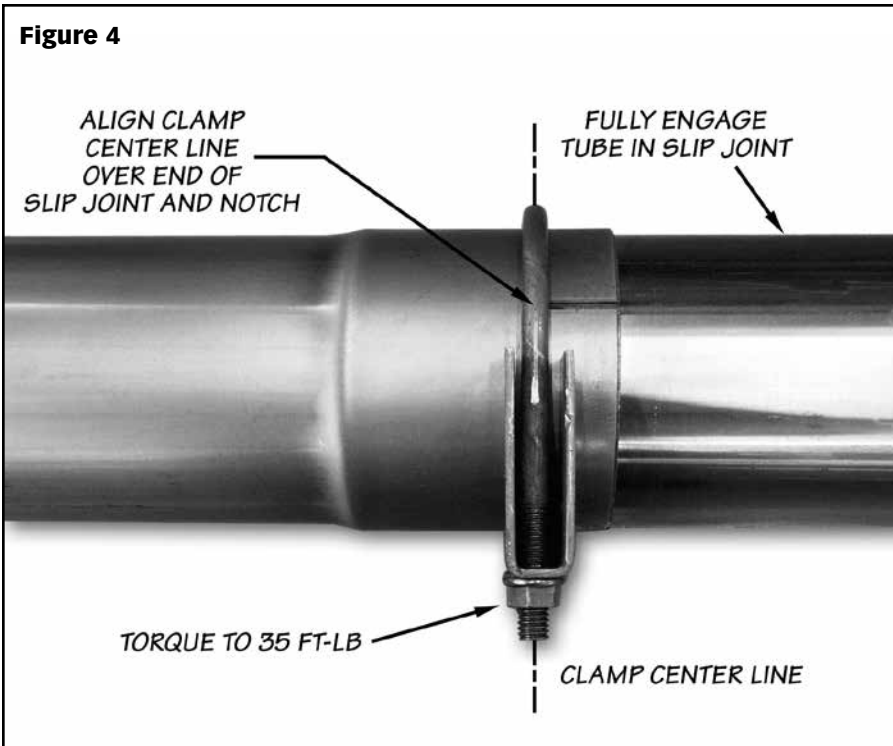

Step 14 thru 21 applies only to single tailpipe systems.

Skip to **Step 22** if installing Banks Split-Dual Monster Exhaust System.

Single Tailpipe System (Step 14 thru 21)

14. Slide one (1) of the supplied 4-inch exhaust clamps over the Banks intermediate pipe.

Note: On extended cab long-bed and crew-cab long-bed vehicle, the clamp that is used between the intermediate pipe and muffler is a combination hanger/clamp. When this hanger clamp is installed the hanger pin should be inserted into the factory rubber hanger and the clamp should be rotated until the hanger pin is parallel with the frame-mounted pin before being torqued.

15. Install the muffler onto the end of the intermediate pipe outlet. Be sure that the inlet side of the muffler (see markings on muffler body) is facing toward the front of the vehicle. Orient the muffler such that the "Banks Monster" logo is facing towards the frame and is level with the ground. Verify that the muffler and intermediate pipe are completely engaged.

16. Slide one (1) of the supplied 4" exhaust clamps onto the Banks Monster muffler outlet.

17. Install the tailpipe into the outlet of the muffler. Be sure that the two pipes are completely engaged. Insert the front and rear tailpipe hanger pins into the factory rubber hangers. Rotate the tailpipe until the hanger pins are parallel with the frame mounted pin.

NOTE: Minimum distance between exhaust tip and body a half (1/2) inch.

18. Adjust each of the pipes to ensure that all of the hanger pins are parallel with the frame-mounted pins and that the rubber hangers are all positioned slightly forward (See **Figure 3**). The amount of forward angle on the rubber hangers should increase the farther downstream the hanger is positioned. This allows the hangers to be properly positioned once the exhaust system reaches operating temperature.

19. Tighten the head pipe V-band clamp to 12 ft-lbs (if previously loosened).

Figure 5

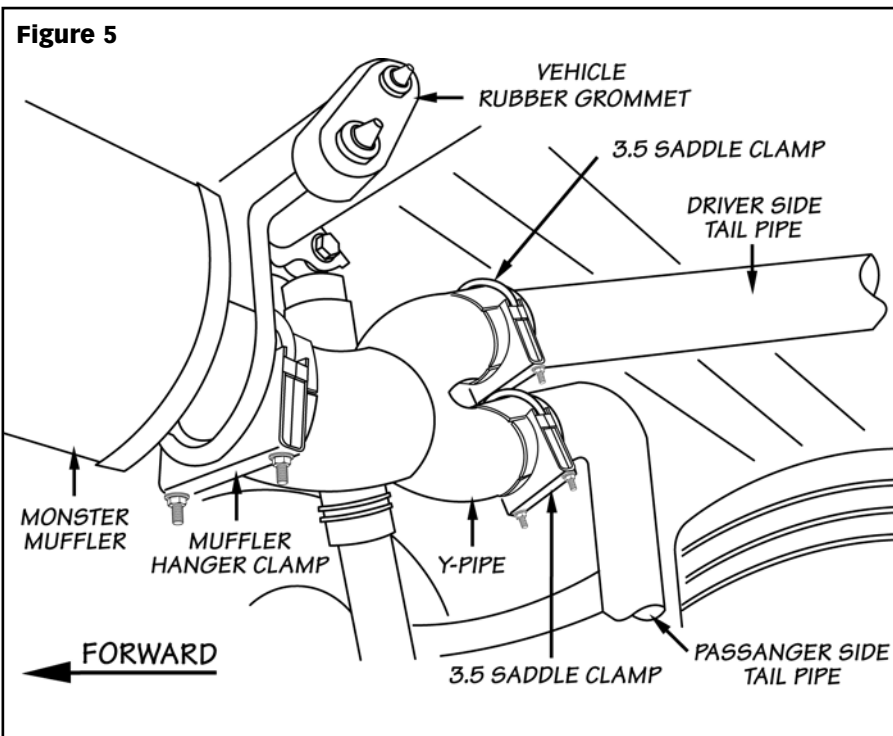

13. Insert the intermediate pipe inlet onto the flanged intermediate pipe outlet. Install the intermediate pipe hanger pin(s) into the vehicle rubber grommets.

NOTE: Once the pipe has been completely engaged in the slip joint, it should be marked with a

marker, scribe or tape for reference when tightening clamps later in the installation. Each slip joint in the system should be marked in this fashion. When the exhaust system is being adjusted to align the hangers, the slip joints can be adjusted so that the reference mark is no more than 1/4" away from its original position.

20. Tighten the exhaust clamp at each of the three (3) joints. **Figure 4** illustrates the proper location of an exhaust clamp on a tubing joint. Torque the nuts on each of the exhaust clamps to 35 ft-lb. Note: If a combination hanger/clamp is utilized, evenly torque nuts to 35 ft-lb. The clamps only need to be tight enough to form a seal and hold the pipes together. Over tightening the clamps may cause the system to leak due to the pipe being crimped. Torque the four (4) factory flange nuts, previously removed, to 30 ft-lbs.

21. Install exhaust tip by sliding it over the outlet of the tailpipe. The tip should be positioned so that the outlet of the exhaust tip is approximately one (1) inch past the outlet of the tailpipe or where aesthetically pleasing.

NOTE: On vehicles with dual rear wheels, the outlet of the tip should be placed approximately 3.5 inches past the outlet of the tailpipe.

Torque the band clamp to 35 ft-lb. Skip to **Step 34** to complete Banks Monster Exhaust System.

BANKS SPLIT-DUAL MONSTER EXHAUST SYSTEM (Step 22 thru 33)

22. Install a 4" saddle clamp onto the Monster muffler inlet. Install the Monster muffler inlet onto the Banks intermediate pipe outlet. Be sure that the inlet side of the muffler (see markings on muffler body) is facing toward the front of the vehicle. Orient the muffler such that the "Banks Monster" logo is facing towards the frame and is level with the ground. Verify that the muffler and intermediate pipe are completely engaged.

23. Install the muffler hanger clamp onto the muffler outlet. Insert the hanger pin into the vehicle's rubber grommet.

24. Install the Banks Y-pipe into the muffler outlet such that the outlets are pointing up. Install a 3-1/2" saddle clamp onto each y-pipe outlet (See **Figure 5**).

25. Install the driver-side hanger bracket into the rear of the driver-side frame rail. If a hitch is installed, remove the hitch hardware on the driver-side, install the frame bracket and reinstall the existing hitch hardware.

Figure 6 Short-bed model shown

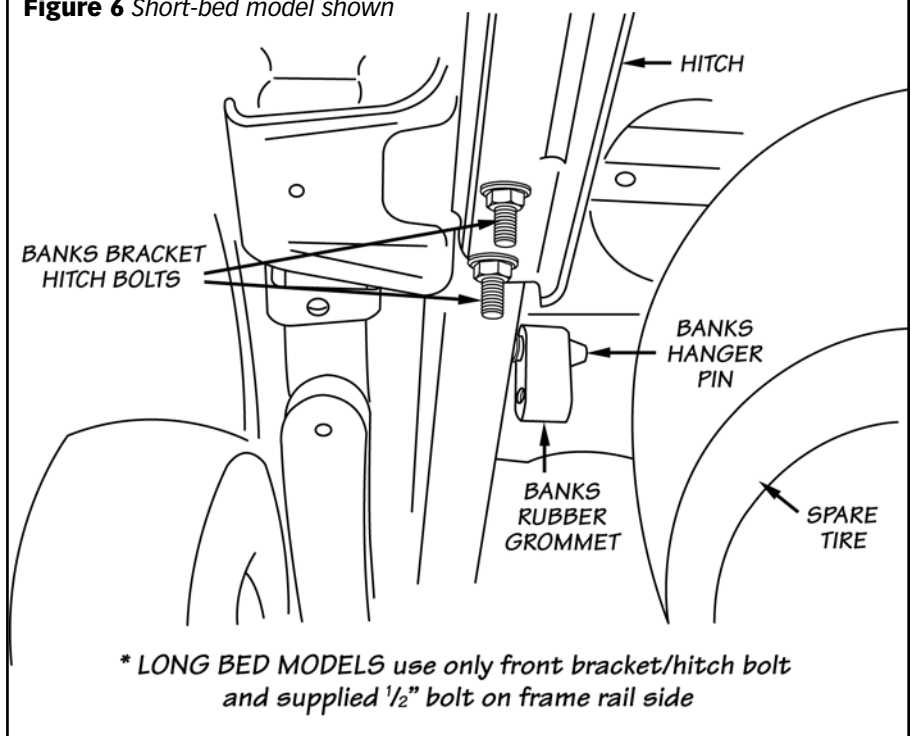

For Long bed models, use one (1) bolt on the flat of frame rail and one (1) bolt on the side of the frame rail.

*For Short bed models, use two (2) bolts on the flat of the frame rail (no bolts on the side). See **Figure 6**.*

26. Install the supplied rubber grommet onto the Banks hanger bracket.

27. Install the driver-side tailpipe (longer) into the top Y-pipe outlet. Install the driver-side tailpipe hanger into the Banks rubber grommet.

28. Install the passenger-side tailpipe (shorter) into the lower Y-pipe outlet. Install the passenger-side tailpipe hanger into the vehicle rubber grommet.

29. Adjust each of the pipes to ensure that all of the hanger pins are parallel with the frame mounted pins and that the rubber hangers are all positioned slightly forward (See **Figure 3**). This allows the hangers to be properly positioned once the exhaust system reaches operating temperature.

30. Be sure that the two (2) tailpipes are completely engaged into the Y-pipe. Rotate the tailpipe until the hanger pins are parallel with the frame-mounted pin. Be sure both tailpipe tips look symmetrical.

NOTE: Minimum distance between exhaust tip and body is a half (1/2) inch.

31. Tighten the head pipe V-band clamp to 12 ft-lbs (if previously loosened).

32. Align the saddle clamps on the radius of the corresponding pipe slots. **Figure 4** illustrates the proper location of an exhaust clamp on a tubing joint. Torque the nuts on each of the exhaust clamps to 35 ft-lbs. Torque the four (4) factory flange nuts, previously removed, to 30 ft-lbs. Torque the hanger bracket 1/2" hardware to 65 ft-lbs.

33. Using the three (3) supplied wire ties, tie any hoses, brake lines or harnesses a minimum of four inches away from the exhaust/tail pipes.

34. Remove the protective covering from the tailpipe tip.

Caution: the protective covering may ignite and burn if not removed prior to running the engine.

35. The Banks Monster Exhaust installation is now complete.

-END, SECTION 1-

Section 2

TECHNI-COOLER ASSEMBLY INSTALLATION

Figure 7
General Assembly
Banks Techni-Cooler Intercooler System

Item	Description	P/N	Qty
1	Techni-Cooler Intercooler	25537	1
2	Boost Tube, Right (2001)	42326	1
	Boost Tube, Right (2002-2004)	42327	1
	Boost Tube, Right (2004.5-2005)	42329	1
3	Boost Tube, Left (2001-2004)	42325	1
	Boost Tube, Left (2004.5-2005)	42328	1
4	Hose, Compressor Outlet to Boost Tube (2001, 2004.5-2005)	94291	1
	Hose, Compressor Outlet to Boost Tube (2002-2004)	94291	2
5	Hose, Intake Manifold to Boost Tube (2001)	94274	1
	Hose, Intake Manifold to Boost Tube (2004.5-2005)	94295	1
6	Hose, Boost Tube to CAC (2001, 2004.5-2005)	94294	1
7	Hose Clamp 3.0"	92860	2
8	Stock Hose	—	*
9	Stock Hose Clamp	—	*

* These are stock components that will be re-used with the Banks Techni-Cooler System

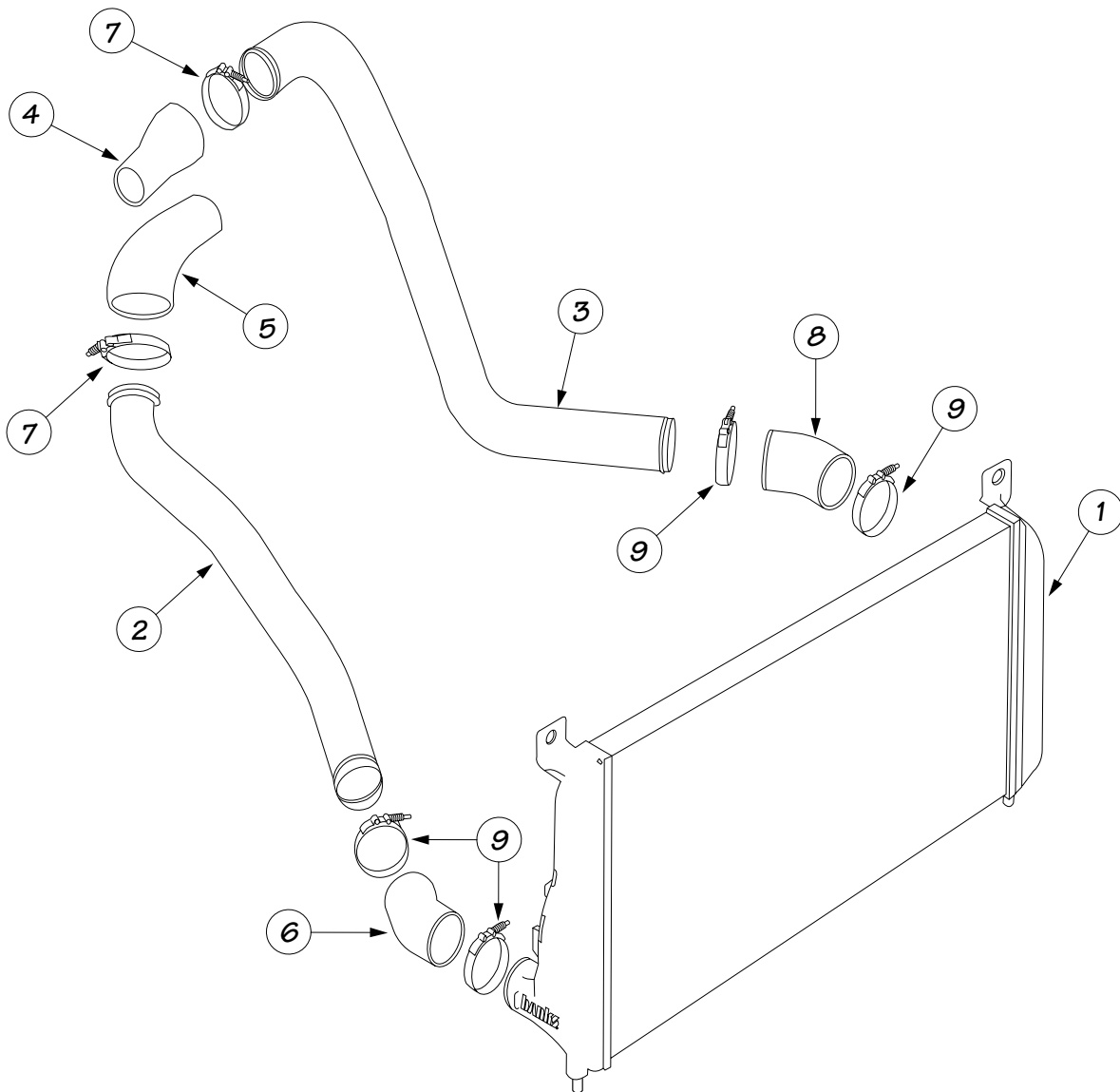

REMOVE STOCK COMPONENTS

1. Make sure the previously removed ground cables from both batteries are still disconnected.

2. Disconnect the mass airflow (MAF) sensor's connector at the air box assembly. *Note: MAF will be installed after Ram-Air intake installation.*

Loosen the hose clamp that joins the inlet air transfer tube to the molded plastic compressor inlet duct. Pull the air box out of the vehicle. It's held in place by plastic fasteners that snap in place. Cover the turbocharger inlet with a clean rag to prevent debris from entering the turbocharger that could result in damage upon start-up

3. Remove the air box mounting tray from the vehicle shown in **Figure 8**.

If installing a Banks Stinger System, Skip ahead to Section 3.

4. Remove the upper grill baffle that mounts between the grill and radiator cross brace. The baffle is held in place by 7 push-in retainers. The retainers are removed by pulling up on the center pin, then prying the retainer out of its hole as shown in **Figure 9**.

5. Remove the grill:

a. 2001 to 2002 vehicles: The grill is retained by (4x) 1/4 turn fasteners, (1x) screw at the latch support, and (2x) snaps at the outboard ends of the grill. Depress the snaps at the ends of the grill before attempting to remove the grill from the vehicle.

b. 2003 to 2005 vehicles: Disengage the snaps at the outboard ends of the grill. Pull the grill from the vehicle.

6. Rotate the headlamp-retaining pin, then remove the pin as shown in **Figure 10a**.

*Note: Some GMC models depending on model year may have a two headlamp-retainer pin. Remove the two retainer pins from headlamp assembly as shown in **Figure 10b**.*

7. Disconnect the connectors from the backside of the headlamp assembly, and remove from the vehicle. Repeat for the driver and passenger side headlamp assemblies.

8. Remove the park/turn signal lamp assembly by depressing the outboard retaining clip, then rotating the assembly outward as shown in **Figure 11**. The headlamp is easily disengaged and does not require force to be removed once the outboard clip has been depressed.

Figure 8 Air box mounting tray



Figure 9 Removal of push-in retaining pins

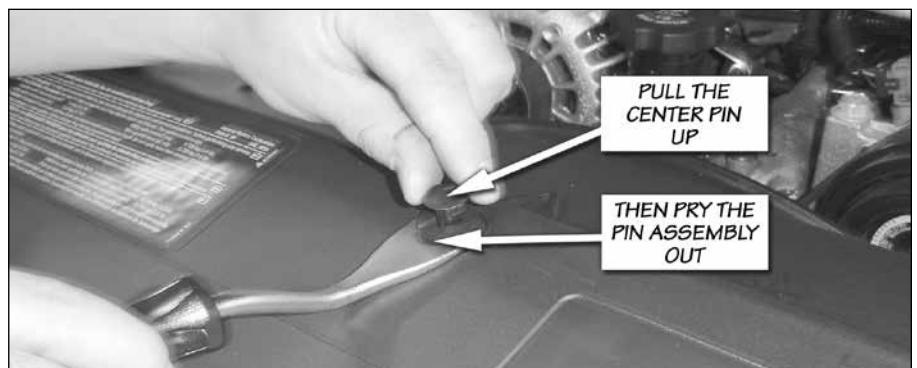

Figure 10a Headlamp assembly removal, Chevy

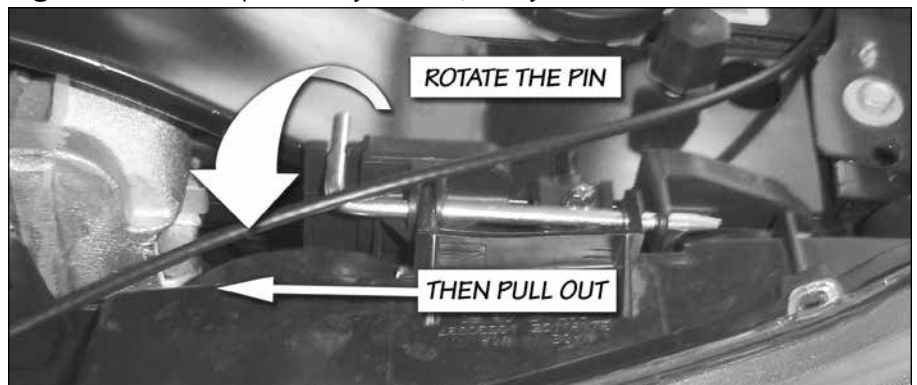

Figure 10b Headlamp assembly removal, GMC

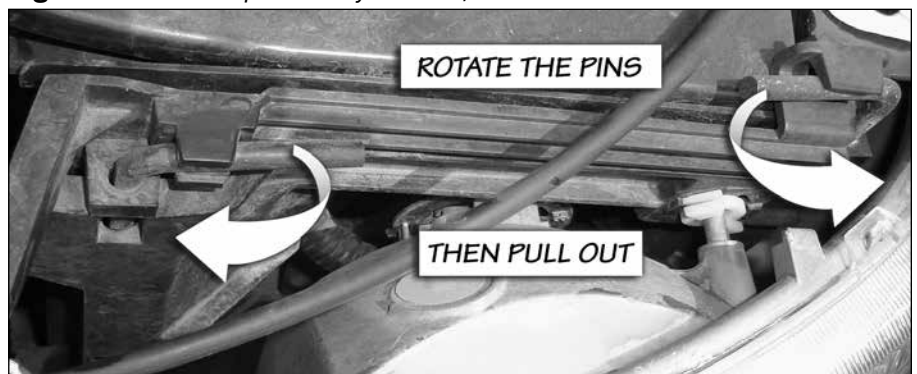

Figure 11 Parking lamp assembly removal

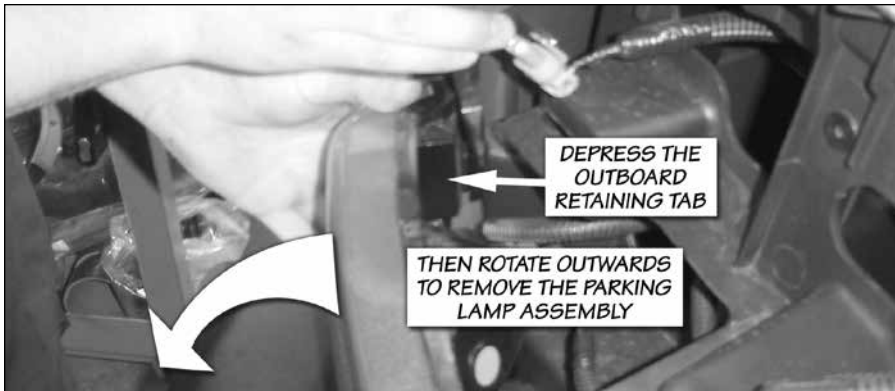

Figure 12 Removal of headlamp/parking lamp assembly support structures

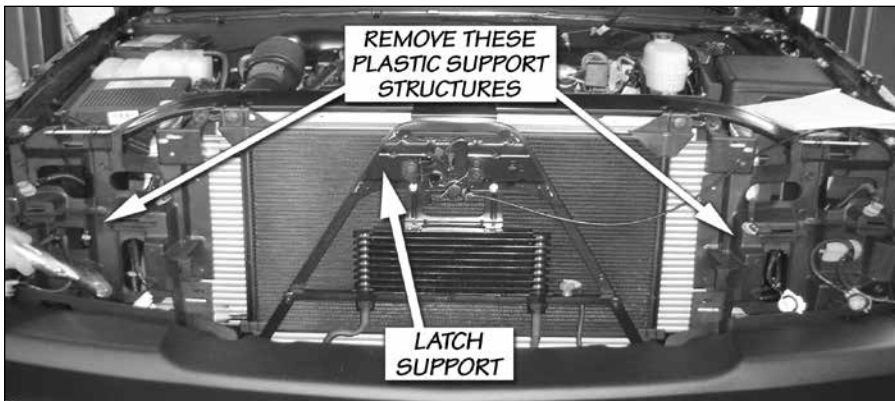

Figure 13 Oil cooler line retaining clip

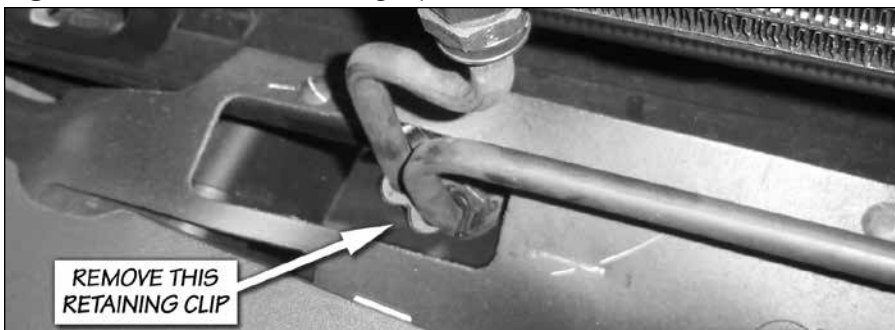

Figure 14 Latch support moved out of the way



9. Remove the bulbs from the turn signal lamp assembly by turning the lamp sockets a quarter turn counterclockwise.

10. Remove the plastic headlamp mounting structure on the driver and passenger side of the vehicle shown in **Figure 12**. There are (6) bolts, (2) torx head bolts, (1) push-in retainer and (1) large clip that must be disconnected to remove the piece from the vehicle, per side. The plastic piece that resides by the bumper must be detached from the headlamp mounting structure, but will remain on the vehicle. The retaining clip that attaches the hood latch cable to the support structure must also be removed on the driver's side.

11. Remove the four bolts that secure the upper fan shroud to the upper radiator cross brace. Remove the four push-in retainers (2 per side) that attach the upper section to the lower section of the fan shroud. These retainers are removed by pulling up on the center pin then prying the entire retainer assembly out as shown in **Figure 9**.

12. Remove the upper section of the fan shroud from the vehicle. Take care not to damage the face of the radiator when removing the shroud.

13. Remove the two upper condenser mounting bolts that attach to the radiator cross brace.

14. Mark the location of the hood latch, then remove the hood latch from the latch support. The latch is held in place by three bolts. The latch support is shown in **Figure 12**. It is not necessary to remove the cable from the latch, just place the latch and cable assembly out of the way.

15. Remove the two bolts that attach the latch support to the radiator cross brace and the 4 lower attachment bolts (2 per side). The two bolts that attach the upper support to the radiator cross brace are accessed from the engine compartment side of the vehicle.

16. Remove the oil-cooler-line retaining clip as shown in **Figure 13**.

17. Swing the latch support forward as shown in **Figure 14**.

18. Pull the air conditioning condenser out of its lower mounts, and place it against the latch support.

19. Remove the two upper Charge Air Cooler (CAC) mounting bolts and unfasten the fender support rod from the radiator cross brace as shown in **Figure 15**.

TRIM BRACKETS

20. Remove the 6 bolts (3 per side) that secure the radiator cross brace. The bolts are on the bottom side at each end of the support. Remove the cross brace from the vehicle.

21. Remove the air box support bracket shown in **Figure 16**. There is an a/c condenser line retaining clip and a plastic fastener that attaches to the inner fenderwell that must be removed before the bracket can be liberated from the vehicle.

22. Trim the air box support bracket per the template in **Figure 55** in **page 35**. **Figure 17** shows the bracket before and after trimming.

23. Remove the 8 pushpin fasteners and 2 large head plastic fasteners that attach the driver's side fenderwell. The fasteners are accessed through the wheel arch opening. Pull the fenderwell down approximately 6 inches once the fasteners are removed. Disconnect the wire harness retaining clips on top of the fenderwell, then remove the fenderwell from the vehicle.

24. Loosen the driver and passenger side boost tube attachment hoses. Do not damage the hoses that attach to the charge air cooler (CAC), the driver's side hose will be re-used. Remove the boost tubes and hoses from the vehicle. The driver side boost tube should be removed through the fenderwell and the passenger side upward through the engine compartment. Cover the intake manifold and turbocharger discharge to prevent foreign debris from entering during the installation.

Figure 15 Upper Charge Air Cooler (CAC) attachment bolt

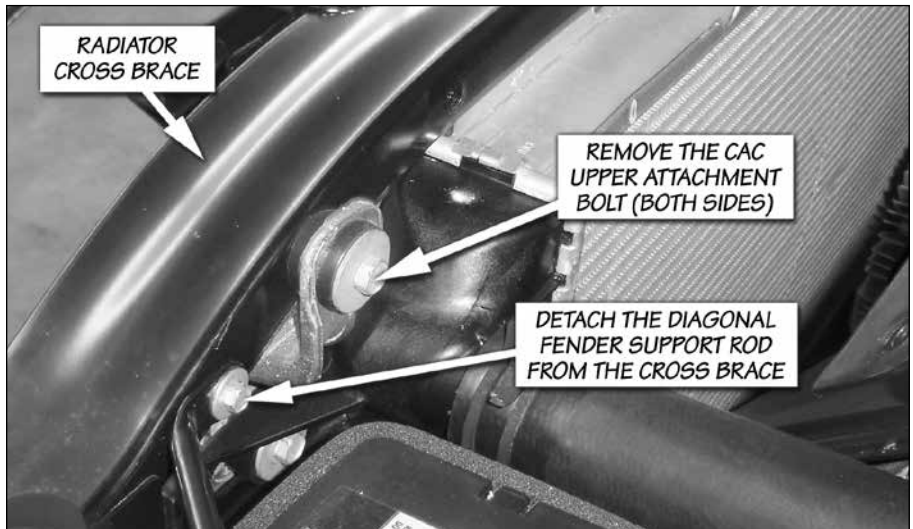

Figure 16 Air box support bracket

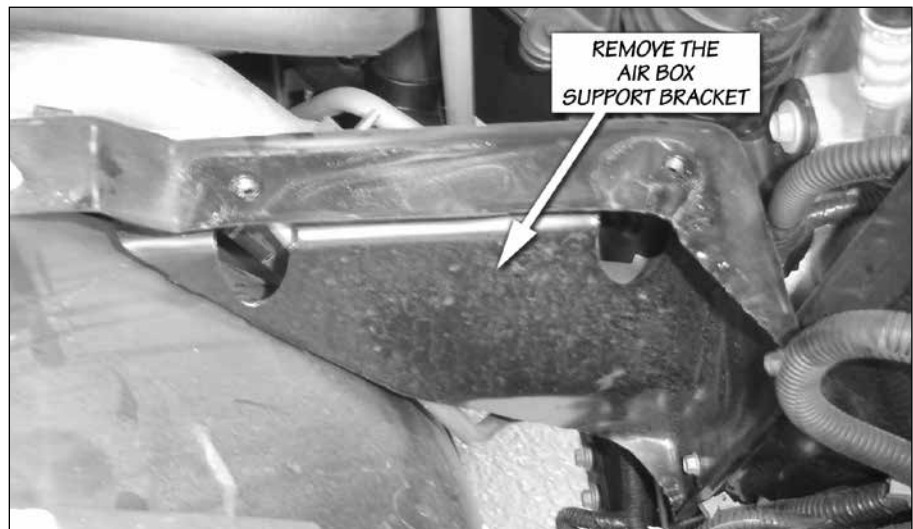

Figure 17 Before and after removing material from the air box support bracket.

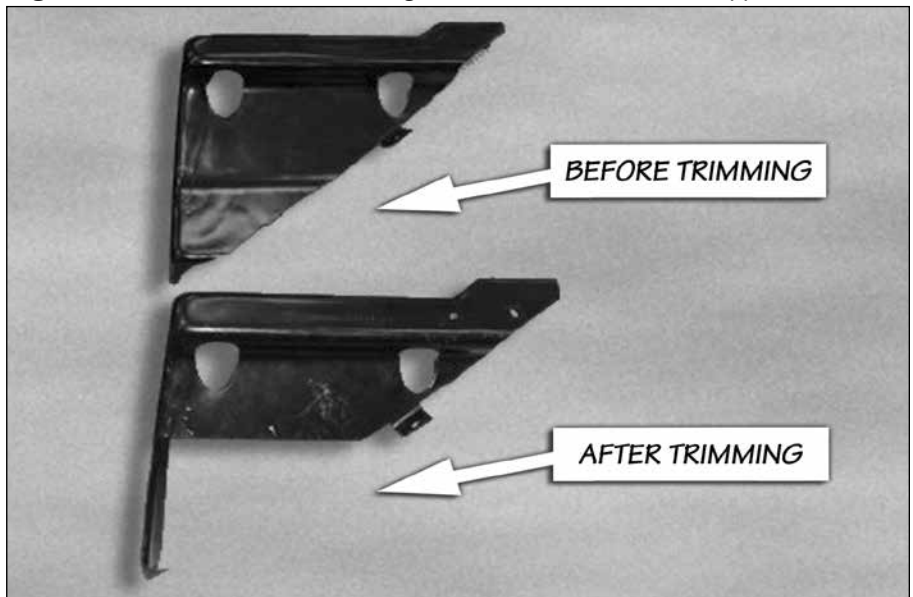

Figure 18 Radiator attachment bolt and lower clamp

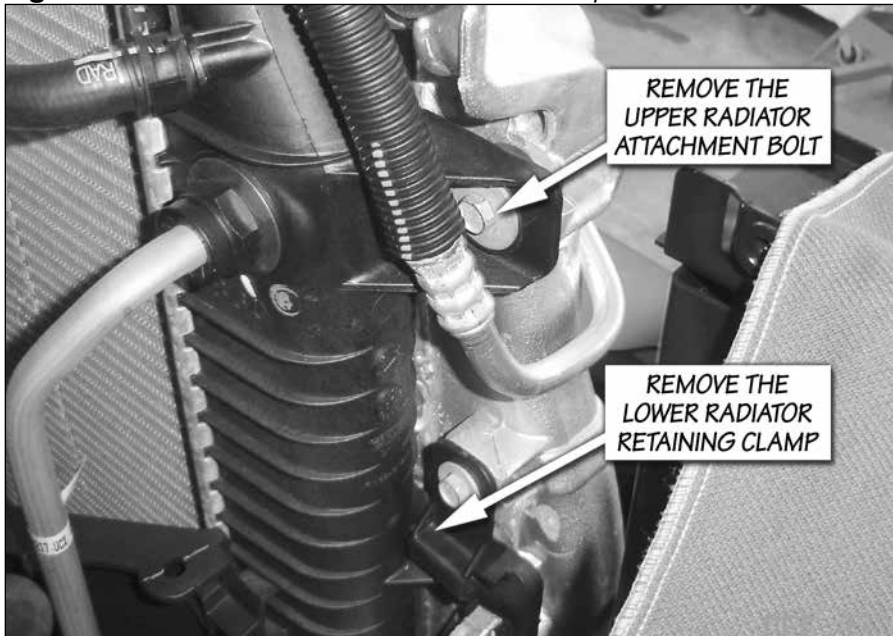
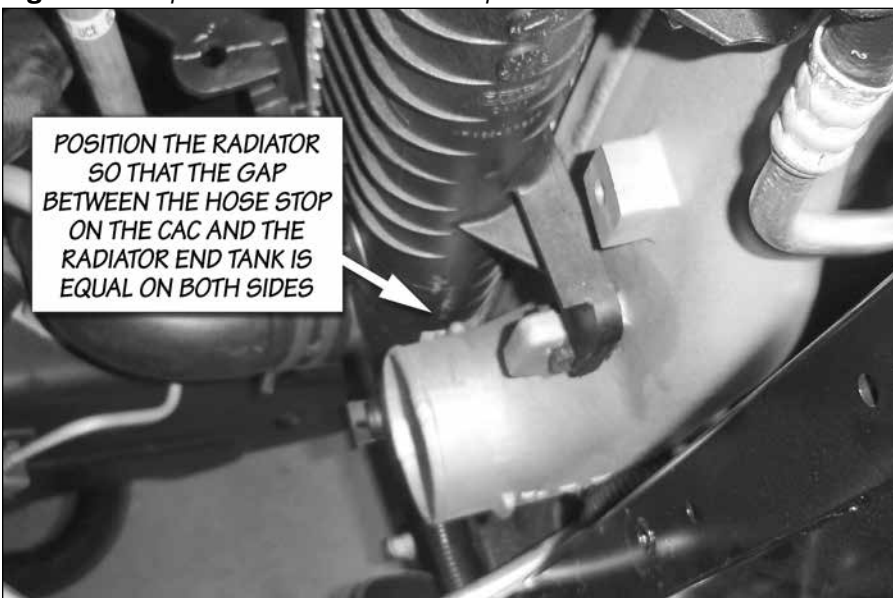

Figure 19 Gap between the CAC hose stop and radiator end tank



25. Remove the radiator attachment bolts and the lower retaining clamps shown in **Figure 18**.

26. Lift the radiator out of its lower saddle mounts and position it towards the engine so that it is no longer attached to the charge air cooler. Take care not to damage the radiator cooling fins.

27. Remove the charge air cooler from the vehicle. Check that the lower mounting peg grommets remained in the vehicle's frame. Return them to their home on the

vehicle's frame, if they came out with the charge air cooler.

28. Remove the metal sleeve from the upper CAC isolation grommets. Remove the grommets from the stock charge air cooler and place them on the Banks Techni-Cooler. Reinstall the metal sleeves in the grommets in the same orientation as they were removed from the stock CAC.

29. Remove the lower radiator saddle mount grommets from the stock CAC and install them on the Banks CAC.

BANKS TECHNICOOLER INSTALLATION

30. Place the Banks CAC in the vehicle. Align the lower CAC mounting pegs with the rubber mounts in the vehicle's frame. There is a significant amount of play in the rubber mounts that can allow them to be aligned with the CAC as required.

31. Reinstall the radiator into the lower saddle mounts of the Banks CAC.

32. Reinstall the radiator cross brace. Leave the attachment bolts loose to aid in aligning the CAC with the support.

33. Install the upper CAC attachment bolts that were previously removed. There is enough play in the lower mounting pads, that the CAC can be positioned to align with the upper cross brace. Tighten the bolts.

34. Position the radiator so that it's centered on the CAC. Check the gap between the hose stops on the CAC and the radiator end tanks on each side of the CAC. Reposition the radiator relative to the CAC until the gap is equal on each side. The location to check is shown in **Figure 19**.

Figure 19.

35. Check that the engine cooling fan can freely spin without contacting the lower fan shroud. If the fan contacts the shroud, the shroud must be realigned with the radiator. The correct alignment is shown in **Figure 20**.

Each side of the shroud should overlap the radiator headers, and the mounting tabs should fit into their respective bosses as shown in **Figure 20**.

36. Secure the radiator to the Banks CAC with the $\frac{5}{16}$ "-18 by 1.0" long bolts and large OD washers that were supplied with the Banks system. Tighten to 10-12 ft-lbs.

37. Install the lower driver side radiator-retaining clamp that was removed from the stock CAC and secure with the $\frac{5}{16}$ "-18 by 0.5" long bolts and the smaller OD washers that were supplied with the Banks system. Tighten to 10-12 ft-lbs. The passenger side clamp will contact the battery support bracket, and is optional to reinstall.

38. Tighten the 6 radiator cross brace bolts to 80 in-lbs. Install the diagonal fender support brace and tighten the bolts.

39. Insert the supplied round metal spacers into the rubber shroud gasket as shown in **Figure 21**. The spacers should be inserted so that the step mates with the cross brace.

40. Install the upper fan shroud. The supplied gasket is used to fill the gap between the shroud and the cross brace. The push-in retainers that secure the upper shroud to the lower shroud are secured by inserting the retainer with the center pin pulled out. Once the retainer is inserted, press the center pin down to secure the retainer. Install the gasket and upper fan shroud bolts. The stock upper fan shroud bolts are reused and should be tighten to 80 in-lbs.

41. Install the a/c condenser and tighten it's upper mounting bolts to 80 in-lbs

42. Install the latch support. Tighten it's six attachment bolts to 80 in-lbs. Install the oil-cooler-line retaining clip shown in **Figure 13**.

43. Install the hood latch. Position it so that it aligns with the marks that were previously made on the latch support prior to it's removal. Tighten it's bolts to 80 in-lbs.

44. Install the driver and passenger side plastic headlamp support structures. Tighten the screws to 80 in-lbs.

45. Install the light bulbs into the park/turn signal lamp assemblies. These are held in place by turning them clockwise. Install the park/turn signal lamp assembly onto the vehicle for both the driver and passenger side.

46. Install the electrical connectors to the headlamp assembly. Install the headlamp assemblies and secure them with their retaining pins.

47. Install the grill:

a. 2001 to 2002 vehicles: The grill is retained by (4x) ¼ turn fasteners, (1x) screw at the latch support, and (2x) clips at the outboard ends of the grill. Tighten the screw at the latch support to 75 in-lbs.

b. 2003 to 2005 vehicles: The grill is held in place by retaining clips, and can be snapped in place.

Figure 20 Lower fan shroud fitment with the radiator

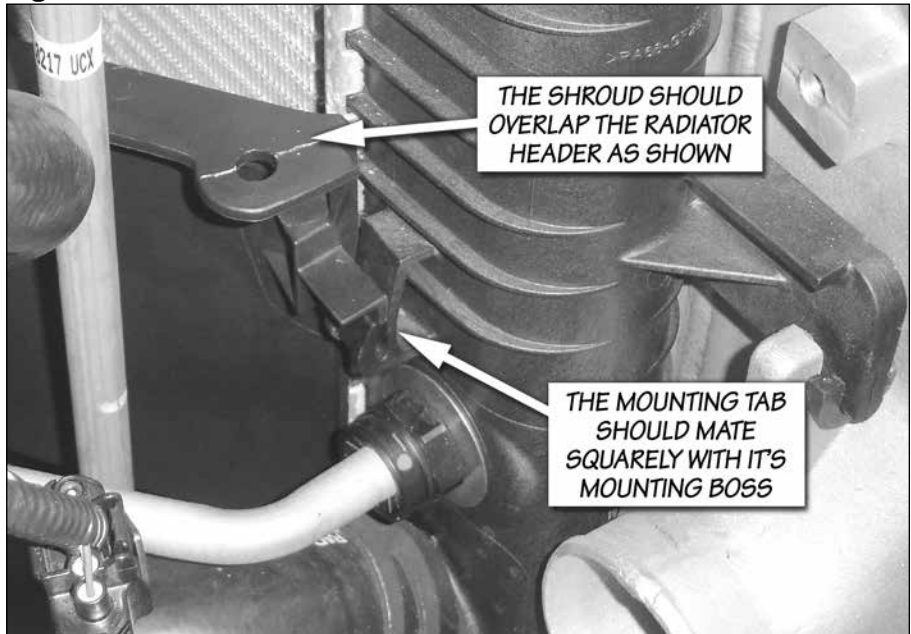
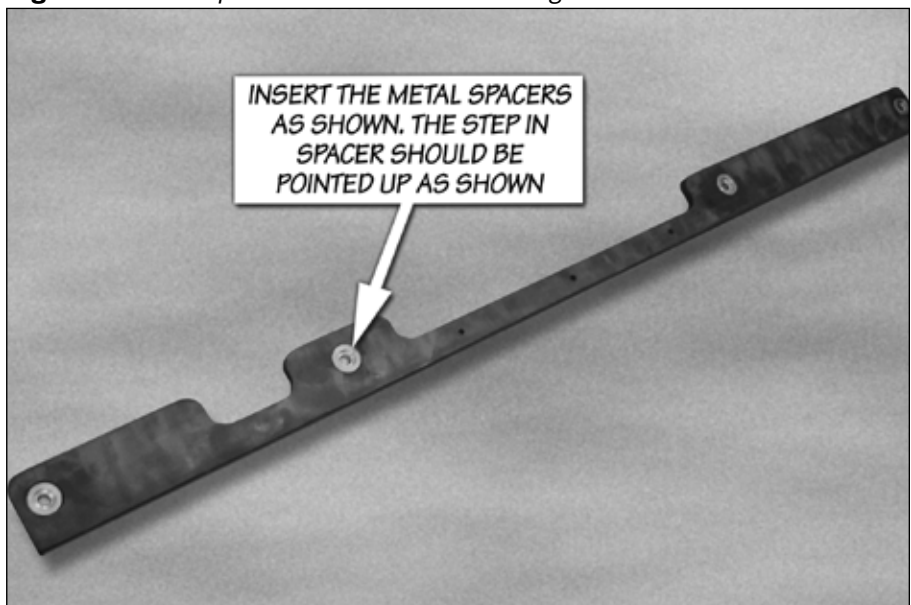

Figure 21 Metal spacers installed in the shroud gasket



48. Install the upper grill baffle and secure with the seven push-in retainers that were previously removed. The push-in retainers that secure the grill baffle are secured by inserting the retainer with the center pin pulled out. Once the retainer is inserted, press the center pin down to secure the retainer.

NOTE: Before slipping any boost tubes and the corresponding hoses, into position, ensure that all connection ends are clean and free of any oil residue and contaminants. Clean compressor outlet and all

connection points with a non-oil based solvent such as Acetone, Mineral Spirits, Denatured Alcohol or Lacquer Thinner. Read and follow the manufactures operation instruction for non-oil based solvent cleaner.

49. Install the driver and passenger side boost tubes. New clamps are provided for the intake manifold hose to boost tube connection and the turbo hose to boost tube connection. All other locations reuse the factory clamps. Tighten the clamps to 75 in-lbs. The following hoses are used at each location:

2001 vehicles:

Turbocharger outlet: 3 inch to 2³/₈ inch ID straight reducer

CAC inlet (driver side): Re-use factory hose

CAC outlet (passenger side): Uniform 3 inch ID with 145-degree bend

Intake manifold: 3 inch to 2³/₈ inch ID with 120-degree bend

2002 to 2004 LB7 vehicles:

Turbocharger outlet: 3 inch to 2³/₈ inch ID straight reducer

CAC inlet (driver side): Re-use factory hose

CAC outlet (passenger side): Re-use factory hose

Intake manifold: 3 inch to 2³/₈ inch ID straight reducer

2004.5 to 2005 LLY vehicles:

Turbocharger outlet: 3 inch to 2³/₈ inch ID straight reducer.

CAC inlet (driver side): Re-use factory hose.

CAC outlet (passenger side): Uniform 3 inch ID with 145-degree bend.

Intake manifold: 3 inch to 2³/₈ inch ID with 120-degree bend.

50. Install the driverside wheel well. Install the lower air cleaner support bracket. Tighten the bolts to 80 in-lbs. Do not reinstall the air cleaner mounting tray. It will not be reused. However, the fasteners will be used for installation of the Ram-Air filter housing.

-END, SECTION 2-

Section 3 THERMOCOUPLE INSTALLATION

1. The thermocouple monitors the temperature of the exhaust gases entering the turbocharger at the turbine housing. Installation requires that the exhaust manifold be drilled near the manifold outlet. It is recommended that the manifold be removed from the engine to thoroughly clean out all metal chips from drilling. If manifold is not removed from the vehicle, all chips must be removed from the manifold. This may be accomplished by using a magnet to extract the chips after drilling. The tap should be greased before use and the chips again removed with a magnet. All metal shavings must be cleaned from the manifold to avoid turbine damage.

2. Remove passenger side wheel well.

3. On the passenger side, remove the hardware retaining the turbine inlet exhaust pipe to the exhaust manifold using a 12mm, 12pt socket along with a 12mm, 12pt wrench, then remove the exhaust manifold from vehicle. Pay special attention to the orientation of the manifold outlet gasket. Retain the hardware and gaskets for re-assembly.

4. Center punch and drill through the passenger side exhaust manifold into the rear passage at the location shown **Figure 22**. Use a 7/16" drill, keeping the drill perpendicular to the manifold surface.

5. Tap the drilled hole with a 1/4" NPT pipe tap. Check the thread depth as you tap by periodically removing the tap and screwing the thermocouple insert into the tapped hole.

6. Install the thermocouple insert into the manifold using anti-seize compound on the threads. Install the probe in the thermocouple insert.

7. Make sure to remove all shavings from inside the exhaust manifold. Reinstall the exhaust manifold. Torque to 28 ft-lb in the sequence shown see **Figure 22**.

8. Attach the thermocouple to the supplied thermocouple leadwire extension with the supplied nuts and bolts. Cover this joint with the supplied heat shrink tubing and heat until the tubing conforms to the joint. Make sure the entire joint is insulated.

9. Route the thermocouple leadwire extension along the factory harness to the driver's side.

*Note: The thermocouple will be connected to the EconoMind harness in **Section 5, Step 5**.*

-END, SECTION 3-

Figure 22

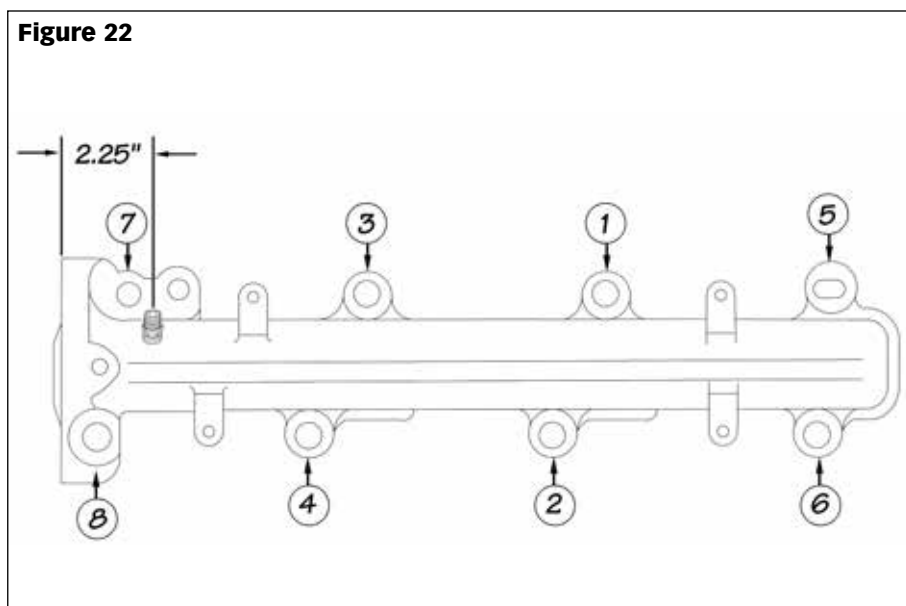

Section 4

BANKS RAM-AIR INTAKE SYSTEM

Figure 23
General Assembly
Banks Ram-Air Intake System

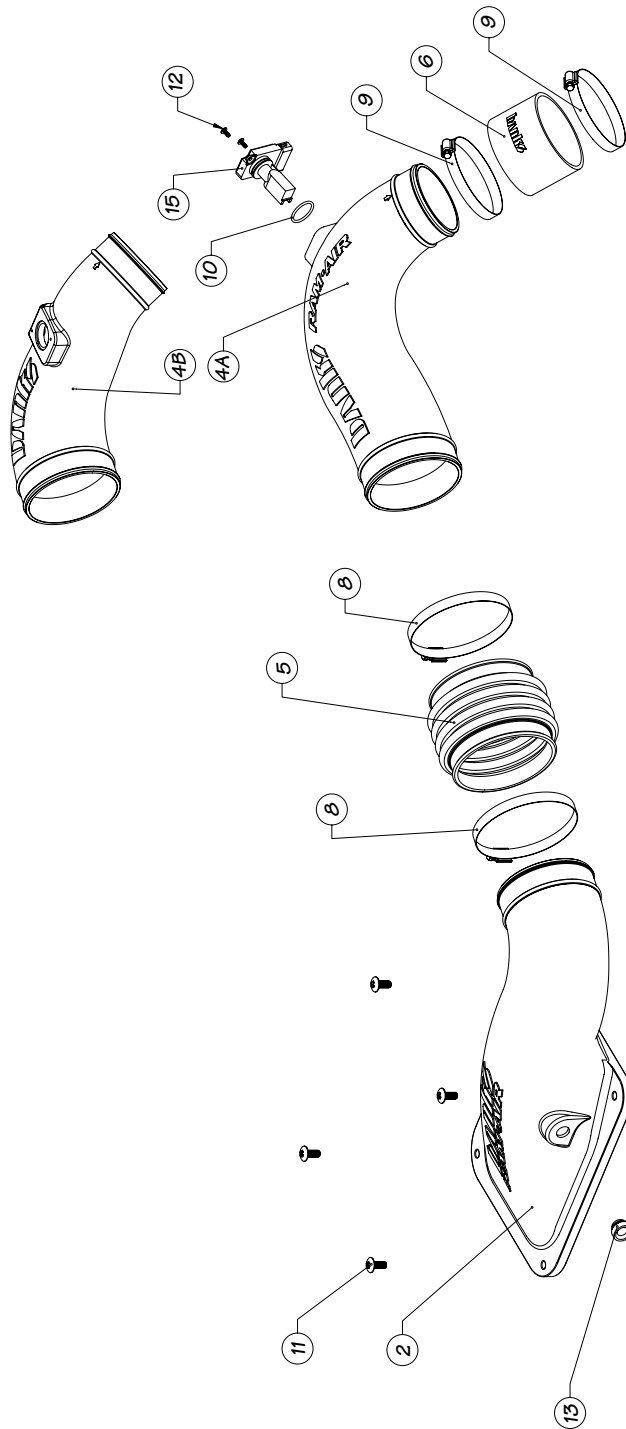

Item	Description	P/N	Qty
1	HOUSING, Ram-Air FILTER	42136	1
2	COVER, Ram-Air HOUSING	42137	1
3	AIR FILTER ELEMENT, Ram-Air SYSTEM	42138	1
4A	INTAKE TUBE, Ram-Air SYSTEM FOR LLY (2004-2005)	42139	1
4B	INTAKE TUBE, Ram-Air SYSTEM FOR LB7 (2001-2004)	42140	1
5	HOSE, BELLOWS, 4.50 I.D.	94300	1
6	HOSE, COMPRESSOR INLET	94298	1
7	HOSE CLAMP, #128	92928	1
8	HOSE CLAMP, #72 w/LINER	92872	2
9	HOSE CLAMP, #56 w/LINER	92857	2
10	O-RING, 50A DUROMETER BUNA, -121 size	93740	1
11	SCREW, TRUSS HEAD, PHILLIPS, 5/16-18 X 3/4	91226	4
12	SCREW, TRUSS HEAD, PHILLIPS, 6-32 X 3/8	91718	2
13	STOCK GROMMET, FILTER MINDER	*	
14	STOCK FILTER MINDER	*	
15	STOCK MAF SENSOR	*	

* These are stock components that will be re-used with the Banks Ram-Air System.

Figure 24



Figure 25



Figure 26

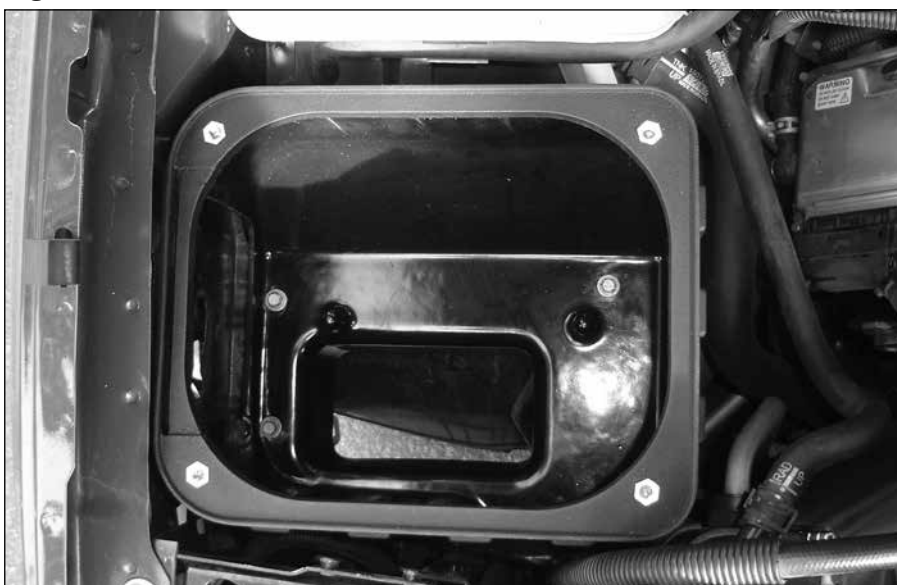

RAM-AIR INSTALLATION

Use the Bill of Materials Chart and the General Assembly Drawing to reference component nomenclature and location. See **Figure 23**. Use caution when working in the engine compartment. Make sure the engine has been OFF for several hours and cool. **Make sure to complete Steps 1 thru 3 of Section 2 before proceeding.**

2001 thru 2004 LB7 Duramax engine

1. You will have either a decorative cover or a resonator covering the intake manifold. The decorative cover may need to be removed in order to facilitate installation and alignment of the Banks Ram-air intake system. Remove the decorative cover by removing the screw securing the rubber grommet. Once the rubber grommet is removed, lift up and unhinge the decorative cover from its mount. Reinstall decorative cover after the installation of the Banks Ram-air system is complete. See **Figure 24**.

If you have the resonator with attached decorative cover then the resonator and attached decorative cover will be removed from the engine and will not be used in conjunction with the Banks Ram-Air intake system. See **Figure 25**.

2. Locate your Banks Ram-Air filter housing from your kit and install as shown in **Figure 26**. The cutout on Banks Ram-Air filter housing must face passenger side fender. Align the Banks Ram-Air filter housing holes with bolt holes in engine compartment. Install the previously removed stock air box bolts to secure the Banks Ram-Air filter housing. Do not tighten the bolts at this time.

3. Locate your Banks Torx tool, T20H in your Banks Ram-Air kit. Use the Torx tool bit to remove the two (2) screws securing the MAF sensor to the stock air box cover.

Note: When removing the MAF sensor, grasp its body and pull up and out. Do not twist or bend when removing.

4. Locate the Banks MAF sensor o-ring supplied in your kit. Install Banks o-ring as shown in **Figure 27**. Ensure o-ring is flush to MAF sensor edge as shown.

Note: Retain stock o-ring. Keep stock o-ring in place, you will be installing the Banks o-ring while retaining the original o-ring on the MAF sensor.

5. Locate your Banks Ram-Air intake tube in your kit. Install the stock MAF sensor (with the additional Banks o-ring) to MAF sensor mounting boss as shown in **Figure 28**. Tighten screws to 3 in/lbs.

Note: Ensure correct alignment as shown otherwise screw holes will not align with screw holes in the Banks Ram-Air intake tube.

Caution: DO NOT OVER TIGHTEN SCREWS

6. Locate the Banks compressor inlet hose and hose clamps from your Banks Ram-Air kit. Loosely fit the hose clamp onto your Banks inlet hose. Install the Banks inlet hose and hose clamp and tighten it to the compressor inlet.

7. Install Banks Ram-Air intake tube to Banks inlet hose and hose clamp. Lightly tighten the hose clamp. *Note: leave the clamps snug to allow movement of the inlet hose to allow correct alignment.*

8. Locate the previously removed stock air box and remove the stock air filter Minder. Make sure to remove the stock air filter Minder rubber grommet as well. See **Figure 29**.

9. Locate the Banks Ram-Air filter housing cover. Install the previously removed air filter minder rubber grommet into the Banks Ram-Air filter housing cover. Once rubber grommet is installed flush into the Banks Ram-Air cover, then locate the previously removed air filter minder and install into the rubber grommet. Make sure air filter minder is installed flush to rubber grommet.

Figure 27

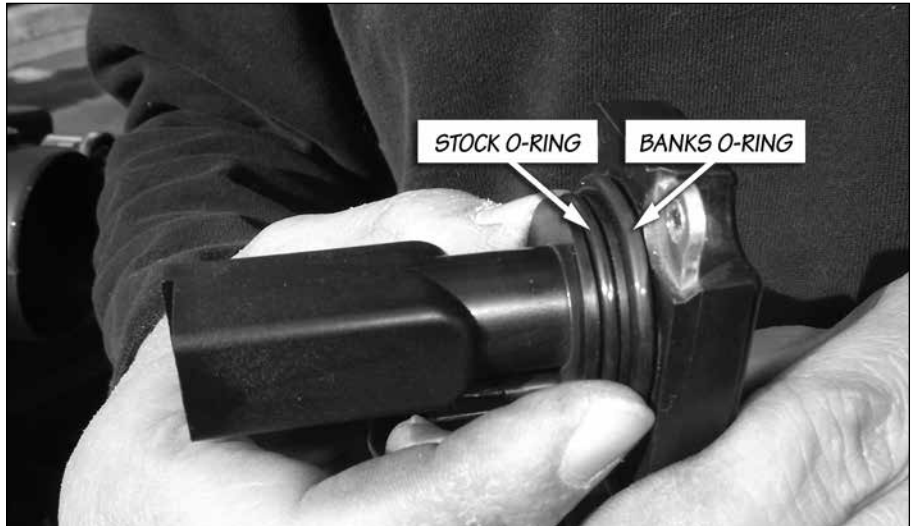

Figure 28



Figure 29



Figure 30



Figure 31



Figure 32

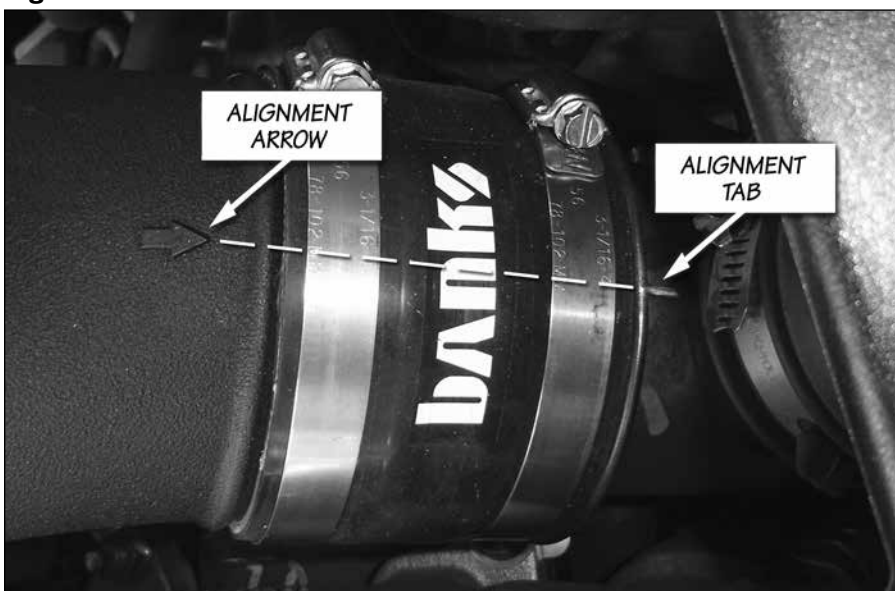

10. Locate the Banks Ram-Air filter and the Banks filter hose clamp. Loosely fit the Banks Ram-Air filter clamp to the Banks Ram-Air filter.

Note: See **Figure 30** to reference the correct alignment locator groove to the Banks Ram-Air filter.

11. After verifying the correct alignment between the Banks Ram-Air filter and the Banks Ram-Air cover, snap fit the two pieces together until an audible snap is heard. This process will ensure that a correct seal has been established.

12. Tighten the Banks Ram-Air filter hose clamp to the Banks Ram-Air filter cover.

13. Place the Banks Ram-Air filter cover onto the Banks Ram-Air housing. Locate the screws for the Banks Ram-Air housing cover in your kit. Align and loosely fit the Banks Ram-Air cover onto the Banks Ram-Air housing.

Note: Use the Banks Ram-Air cover and Banks Ram-Air housing to fine tune alignment between Banks Ram-Air intake tube and Banks Ram-Air filter cover. The Banks Intake Tube can be rotated to facilitate in alignment. See **Figure 31** and **Figure 32**.

CAUTION: Ensure intake tube is not touching any engine components, specifically the boost tube and intake manifold hose clamps.

14. Tighten the upper (top) hose clamp intake tube.

15. Remove the Banks Ram-Air housing cover screws and remove the Banks Ram-Air housing cover.

Note: Be careful not to disturb the alignment.

16. Tighten the Banks Ram-Air filter housing bolts to vehicle frame.

17. Install the Banks bellows hose and hose clamp onto the Banks Ram-Air intake tube.

18. Loosely fit the hose clamp to the other end of the bellows.

19. Install the Banks Ram-Air cover into bellows.

20. Install Banks Ram-Air cover w/ filter into the Banks Ram-Air filter housing.

Note: a slight resistance in pressing in the Banks bellows is normal.

21. Now with the Banks Ram-Air filter housing cover and Banks bellows fully seated flush, fasten the Banks cover to the Banks housing using the Banks cover screws and tighten.

22. Make sure that the Banks bellows is flush with the Banks cover connection bead and tighten the Banks bellows hose clamp.

Note: Bellows will need to be compressed slightly.

23. Connect MAF sensor connector to intake tube.

Note: you may have to loosen wire harness clips, to increase slack in length of wire harness available to connect to intake air tube See Figure 33.

24. Re-install the passenger side wheel well.

25. You have successfully completed the installation of the Banks Ram-Air Intake system. See Figure 34. Make sure to go over all hose clamps for tightness and connectors for a sure fit. Make sure that the intake tube is not touching any engine components, specifically the boost tube and intake manifold hose clamps.

-END, SECTION 4-

Figure 33



Figure 34



Section 5

BANKS ECONOMIND DIESEL TUNER INSTALLATION

⚠ FOR IDASH1.8 INSTRUCTIONS, SEE IDASH MANUAL 97654 & 97674

Figure 35
General Assembly
Banks EconoMind Diesel Tuner

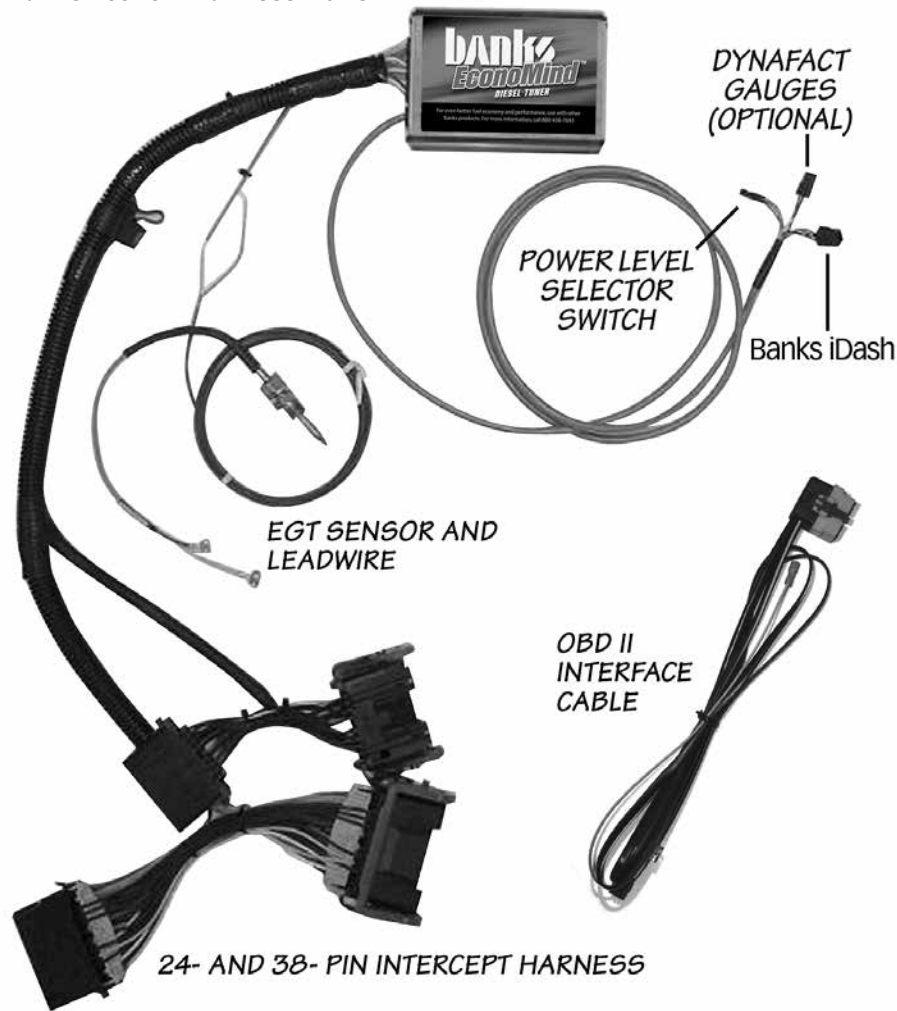

INSTALLATION OF WIRING HARNESS, CONNECTIONS AND EconoMind DIESEL TUNER

- 1.** From the engine compartment, locate the rubber grommet high on the driver's side of the vehicle firewall. The grommet is about 3" in diameter. Make a 1" x 1" cross-shaped incision in the grommet (see **Figure 36**).
- 2.** From the engine compartment, feed the grey three-connector cable through the incision made in the firewall grommet and into the cab. From inside the cab, remove the lower dash panel under the steering column to allow access to these three connectors.

Figure 36

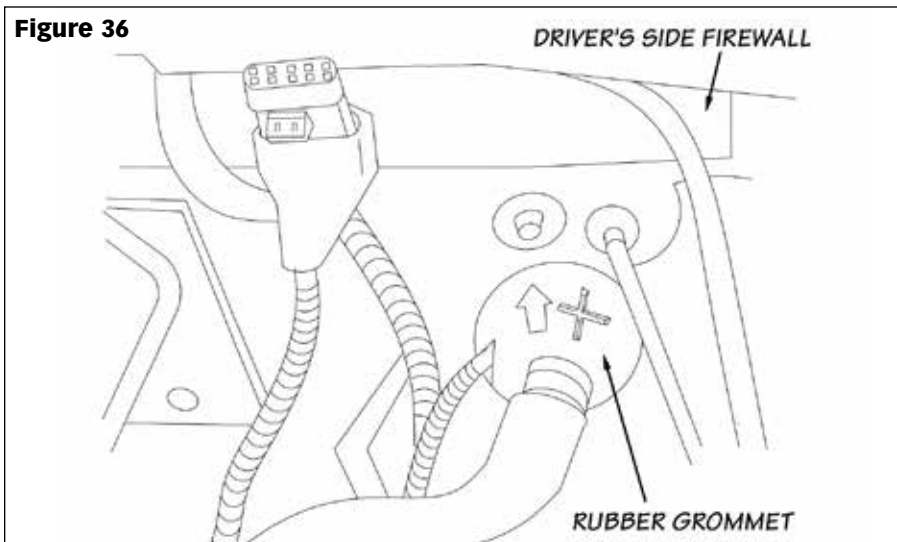

3. Locate the two black wire harness locking connectors between the brake fluid reservoir and the air conditioning compressor. Lift the gray connector locks and disconnect the 38-pin connector pair and the 24-pin connector pair (see **Figure 37**).

4. Insert the male 38-pin connector on the EconoMind harness into the female 38-pin connector on the factory harness. Insert the female 38-pin connector on the EconoMind harness onto the male 38-pin connector of the factory harness. Repeat this process with the 24-pin connectors (see **Figure 37**).

5. Connect the thermocouple leadwire to the EconoMind harness with the supplied nuts and bolts. Cover this joint with the supplied heat shrink tubing and heat until the tubing conforms to the joint. Make sure the entire joint is insulated.

MOUNTING THE BANKS ECONOMIND DIESEL TUNER

6. The EconoMind is to be installed under the hood on the outside of the fuse box, with the wire harness facing towards the rear of the vehicle (see **Figure 38**). Make sure the outside of the fuse box is free of oil, grease and dirt.

7. With the Banks EconoMind Diesel Tuner positioned next to the fuse box, peel the protective backing from the hook and loop interlocking fasteners attached to the Banks EconoMind Diesel Tuner. Position the bottom edge of the Banks EconoMind Diesel Tuner approximately a half inch above the main wiring harness exiting the fuse box, then press the adhesive onto the outside of the fuse box. Apply light pressure to the Banks EconoMind Diesel Tuner by hand for 60- seconds to create a strong bond between the fuse box and hook & loop interlocking fasteners. Using the supplied cable ties, secure the wire harness away from any heat sources or moving components.

-END, SECTION 5-

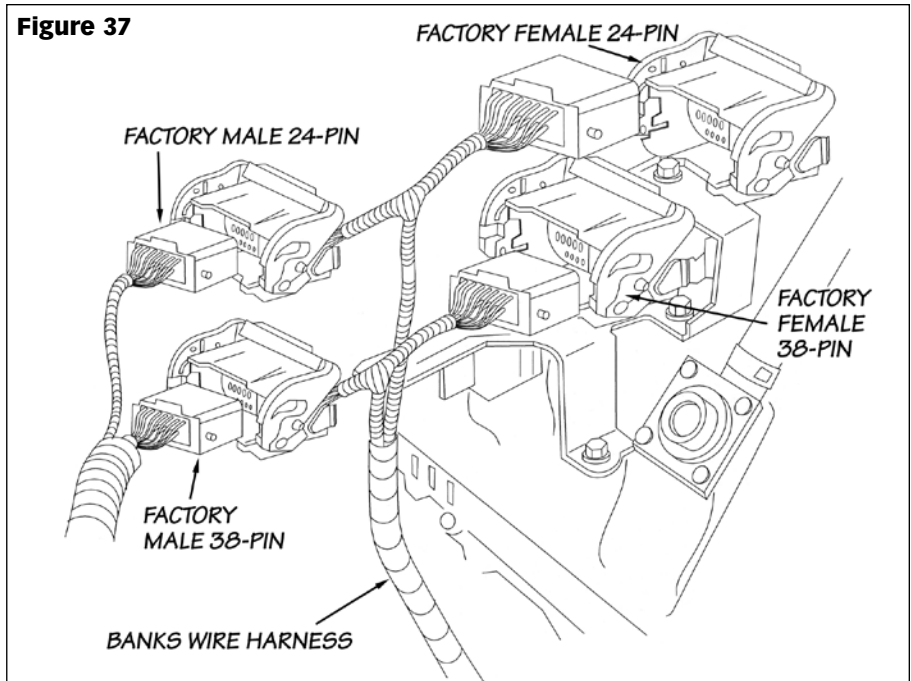

Figure 38 Driver's side of engine compartment



Section 6

MOUNTING AND CONNECTING THE BANKS iDash

 **FOR IDASH 1.8 INSTRUCTIONS, SEE IDASH MANUAL 97654 & 97674**

Section 6 not needed if installing
the Power Level Selector Switch.
Please proceed to **Section 7**.

Section 7

INSTALLATION OF THE POWER LEVEL SELECTOR SWITCH

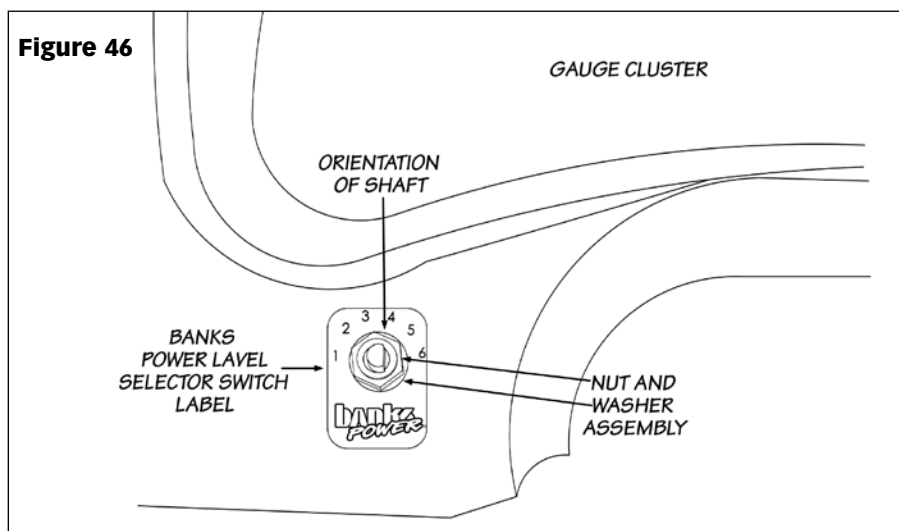
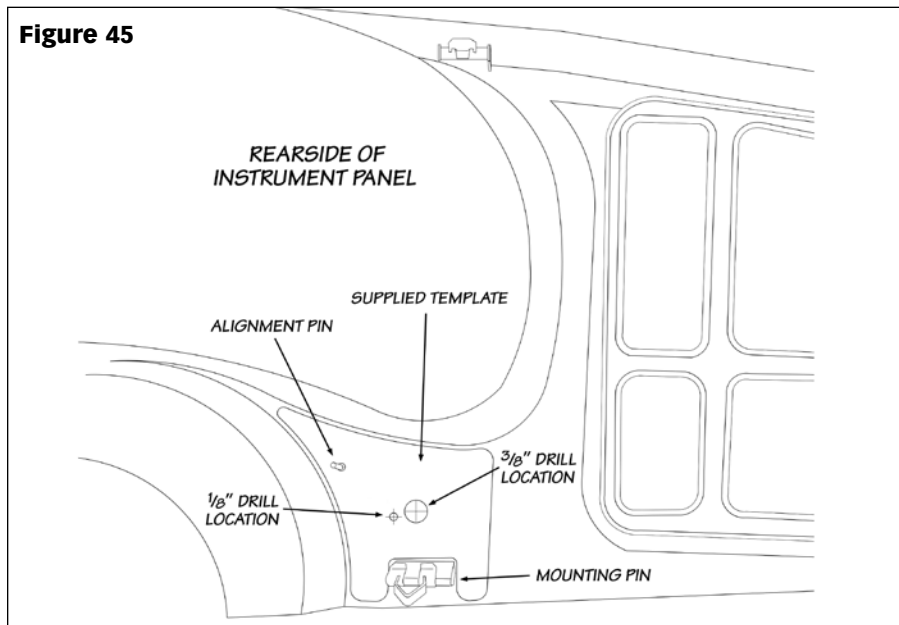
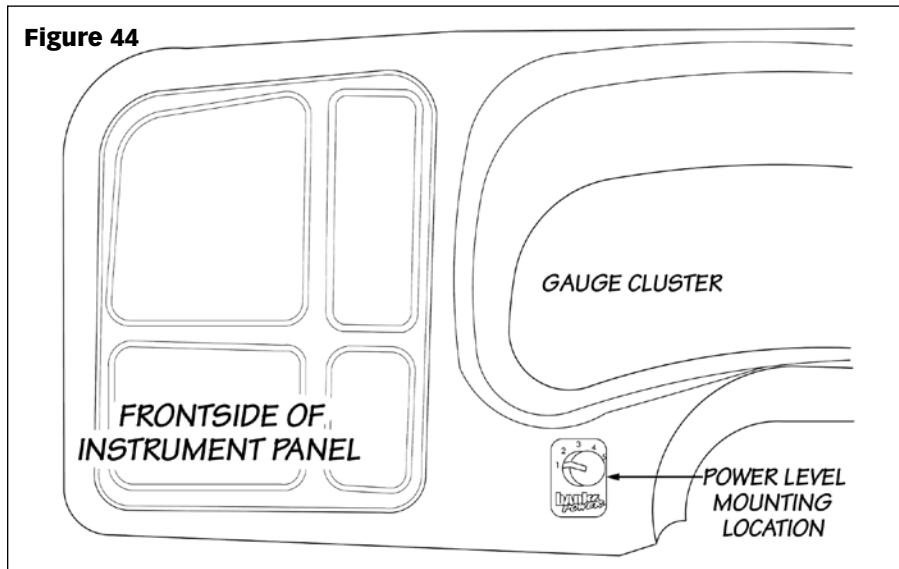

Section 7 not needed if Banks iDash will be installed. Please proceed to **Section 8**.

CAUTION: Do not use force when working on plastic parts. Permanent damage to the part might result.

1. The Power Level Selector switch will be installed on the driver's side of the instrument panel (IP) next to the steering column (see **Figure 44**). Carefully remove the IP from the dashboard by slowly pulling outwards from the dashboard around the edges of the IP, allowing the mounting pins to pull free from their dashboard sockets. Automatic transmission equipped vehicles will need to set the parking brake and move the shift lever down to the lowest gear to allow clearance for instrument panel removal.

2. Cut out the supplied template (see **Figure 56 on page 35**) and align the template onto the rear of the IP, squarely seating it on the top of the IP mounting pin (see **Figure 45**).

3. Using a 3/8" Uni-bit, center the bit onto the 3/8" drill location on the template and slowly drill through the IP. Using a 1/8" drill bit, center and drill through the 1/8" location on the template. Remove and discard the template and any plastic shavings.

4. On the front side of the IP, align the Power Level Selector Switch label onto the previously drilled hole (see **Figure 46**).

5. Remove the nut and internal tooth washer from the Power Level Selector Switch. Rotate the shaft counter clockwise until the shaft stops. Verify the locating washer tab is inserted into the #6 position on the switch (see **Figure 47**).

NOTE: If the washer is in any position other than the #6, your EconoMind Tuner will not select power levels properly.

6. After confirming the locating washer is in the #6 location, install the switch through the 3/8" hole on the backside of the instrument panel. The alignment pin should rest in the 1/8" hole and with the switch fully rotated counter clockwise; the shaft's flat side should be facing the steering column. Secure switch with internal tooth washer and nut.

Snug the washer; be careful not to over torque the nut and damage the plastic threads.

7. Install the knob onto the shaft facing the #1 Level on the Power Level Selector Switch label. On the knob, snug the two (2) set screws with the supplied 0.050" hex key wrench.

8. Route the Power Level Selector Switch cable down to the EconoMind Tuner's three-connector cable underneath the dashboard, and reinstall the IP to the dashboard.

9. Connect the Power Level Selector Switch Cable's 2-pin receptacle to the 2-pin plug on the EconoMind Tuner's grey three-connector cable.

-END, SECTION 7-

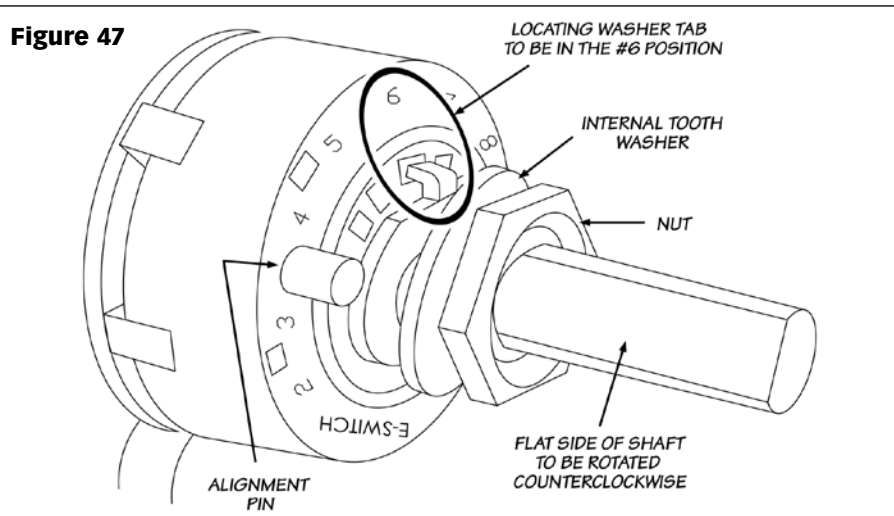

Section 8 OPTIONAL GAUGE CLUSTER INSTALLATION

If not installing optional gauges, Skip to next section.

1. Choose a suitable location under the lower edge of the dash for the mounting of the instrument panel provided where the driver can conveniently view it.

Note: Molded pillar mount and additional gauges are available through Gale Banks Engineering.

2. Using the panel as a template, drill two 3/16" diameter holes in the dash and mount the panel with the supplied machine screws, nuts and star washers provided.

3. Locate the supplied EconoMind wire loom with the 4-pin connector. Connect the 4-pin connector on the EconoMind wire loom to the connection labeled DYNAFACT Gauges on the EconoMind wiring harness. See **Figure 35**.

4. Install the DynaFact boost and pyrometer gauges in the mounting panel using the clamps and thumbnuts provided. Plug the BLACK wire lead to the male spade terminal on the BLACK wire of each gauge wire harness. Plug the YELLOW wire into the Yellow wire of the boost gauge wire harness and the RED wire into the RED wire of the pyrometer gauge wire harness. The ORANGE wire remains unused.

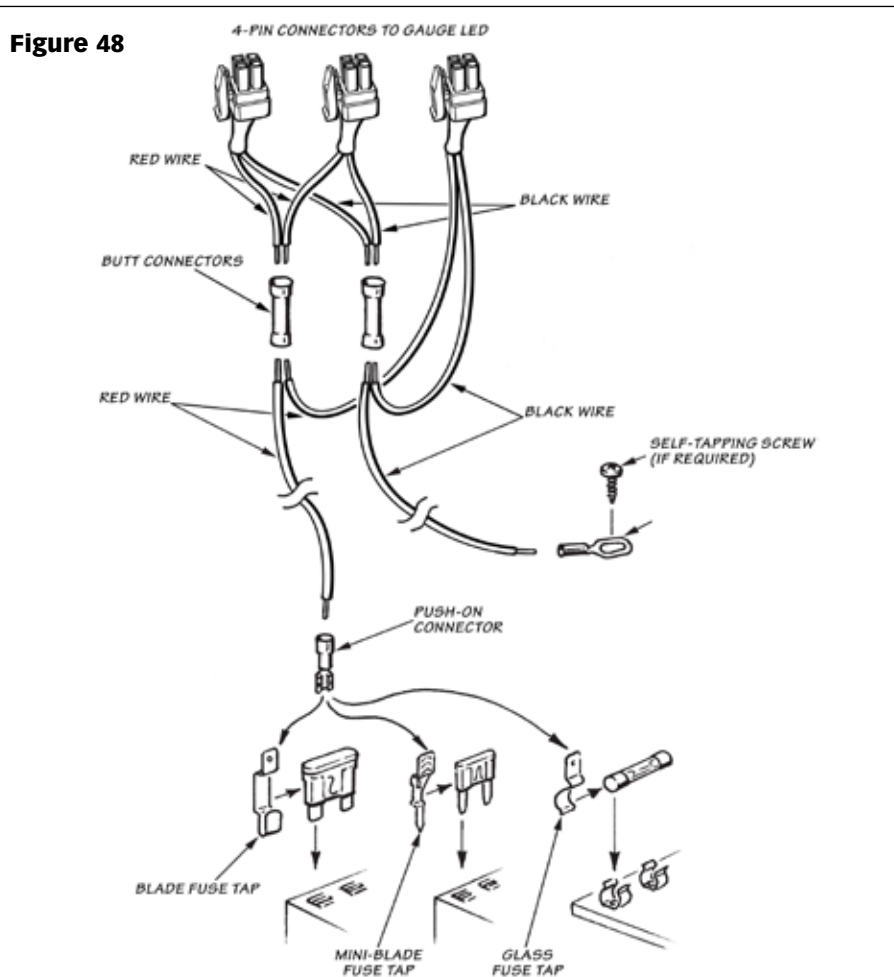

5. Connect the 4-pin connector of each gauge into the back of its corresponding gauge.
 - a. Crimp the remaining Black and RED wires from each 4-pin connector gauge harness to the butt connectors as shown in **Figure 48**.
 - b. Strip one end of the RED wire and crimp it to the butt connector containing the RED wires from step 'a'.
 - c. Strip one end of the BLACK wire and crimp it to the butt connector containing the BLACK wires from step 'a'.

- d. Route the RED wire to the fuse box. Locate the appropriate fuse for instrument lighting in the owner's manual. Cut the RED wire as required and strip the end. Crimp the push on connector to the RED wire and connect to the fuse as shown in **Figure 48**. Alternatively, locate power wire to dimmer switch and install T-tap. Cut the RED wire as required and strip the end. Crimp the push on T-tap connector to the RED wire and connect to T-tap on dimmer power wire.
- e. Locate a metal surface that will serve as an acceptable chassis ground. Cut the BLACK wire to a

sufficient length that will allow it to reach the chassis ground and strip the end. Crimp the ring terminal to the BLACK wire as shown in **Figure 48**.

- f. Drill a 1/8" hole, if required, to attach the ring terminal to the chassis ground. **Caution: If drilling, check the backside to make sure there are no components that may be damaged by drilling.**
- g. Use the supplied self-tapping screw to secure the ring terminal to the chassis ground.

-END, SECTION 8-

Section 9

AUTOMATIC TRANSMISSION LEARNING

*NOTE: Please refer to the Banks iQ Software & Installation Kit, Owners Manual for software installation and operation instruction before beginning **Section 9**, Automatic Transmission Learning.*

The 6.6L GM Duramax Trucks equipped with the Allison 1000 5-speed automatic overdrive transmission use adaptive shift control logic. This will require the transmission to adapt to the additional power created by the Banks Power products before it will shift properly. Failure to follow the sequence can result in damage to the transmission. Perform the following sequence at a location where it is safe to accelerate without exceeding the posted speed limit.

1. With the power selector on level one, start the truck and allow the engine to reach normal operating temperature.
2. Switch to power level two.
3. Drive vehicle in power level two for 5 to 10 miles ensuring a complete shift cycle through each gear. (The transmission shift adaptation learning process requires 15 to 30 complete shift cycles to learn new shift program.)
4. Repeat step 3 for each power level.

WARNING: Take particular care not to do wide open runs in 5th gear when in Automatic transmission Learning Mode. The Allison 1000 5-speed automatic transmission will continually

adapt to the power output of the engine to optimize shift quality. The transmission will quickly adapt to the power setting if the driving cycle includes regular gear changes at high loads. The transmission learning procedure will need to be repeated when switching back to the higher power settings once the transmission adapts to the lower power settings. It will be apparent when the transmission adapts to the lower settings by monitoring the feel of the gearshift. Gear changes will be noticeably harder when initially switching from a higher to lower power setting. This will soften as the transmission adapts to the new setting.

-END, SECTION 9-

Section 10

TROUBLESHOOTING, ECONOMIND

 **FOR IDASH 1.8 INSTRUCCIONES, SEE IDASH MANUAL 97654 & 97674**

Table 1 Banks EconoMind Diagnostic Codes

Code	Event	Course of Action
1,1	Fuel Rail Pressure (FPR) Input Voltage Out of Range	Turn ignition OFF and check the 24-Pin and 38-Pin connectors. Turn ignition back ON and re-check for presence of code.
1,2	Manifold Absolute Pressure (MAP) Input Voltage Out of Range.	Turn ignition OFF and check the 24-Pin and 38-Pin connectors. Turn ignition back ON and re-check for presence of code.
1,3	EconoMind Switch Input Value Out of Range	Turn ignition OFF and make sure either Banks iQ or EconoMind switch is connected to EconoMind tuner. If EconoMind switch is connected (no Banks iQ), check 2-pin connection on tuner's in-cab cable. Turn ignition back ON and re-check for presence of code.
1,4	(LB7) Barometric Pressure Input Voltage Out of Range	Turn ignition OFF and check the 24-Pin and 38-Pin connectors. Turn ignition back ON and re-check for presence of code.
	(LLY) Barometric Pressure CAN Signal Not Available	
2,1	Fuel Rail Pressure (FPR) Output voltage Out of Range.	Turn ignition OFF and check the 24-Pin and 38-Pin connectors. Turn ignition back ON and re-check for presence of code.
2,2	Manifold Absolute Pressure (MAP) Output Voltage Out of Range.	Turn ignition OFF and check the 24-Pin and 38-Pin connectors. Turn ignition back ON and re-check for presence of code.
2,3	Exhaust Gas Temperature (EGT) Sensor Open Circuit.	Turn ignition OFF and check both thermocouple ring-terminal connections. Turn ignition back ON and re-check for presence of code.
2,4	(LB7) OBD Signal Malfunction	Turn ignition OFF and check OBD connector and cable. Turn ignition back ON and re-check for presence of code.
3,1	Crankshaft Position (CKP) Strand Fault or Internal Module Malfunction.	Turn ignition OFF and check the 24-Pin and 38-Pin connectors. Turn ignition back ON and re-check for presence of code.
3,2	Power Up Error or Internal Module Malfunction	Turn ignition OFF and check the 24-Pin and 38 Pin connectors. Turn ignition back ON and re-check for presence of code.
3,3	Low Battery Voltage or Internal Module Malfunction.	Turn ignition OFF and check the 24-Pin and 38-Pin connectors. Turn ignition back ON and re-check for presence of code.
3,4	CAN Communications Error with Vehicle.	Turn ignition OFF and check the 24-Pin and 38-Pin connectors. Turn ignition back ON and re-check for presence of code.
4,1	Injection Control Signal Fault or Internal Module Malfunction	Turn ignition OFF and check the 24-Pin and 38-Pin connectors. Turn ignition back ON and re-check for presence of code.
4,2	Transmission slippage Detected	Transmission is slipping excessively. Code will automatically clear once transmission stops slipping (repaired).
5,1	Internal Module Malfunction	Turn ignition off. Turn ignition back ON and re-check for presence of code.

If problem persists, call Gale Banks Engineering Tech Support.

Diagnosing EconoMind error codes without the Banks IQ.

If you feel that your Banks EconoMind Diesel Tuner is not functioning properly, some diagnostics can be performed. Your EconoMind Diesel Tuner is equipped with diagnostic features that will detect and display certain errors.

Remove the Banks EconoMind Diesel Tuner from its mounting location while keeping all connectors plugged in, and position it in such a way that you can view the end of the EconoMind housing that contains the LEDs from the driver's seat. Turn the vehicle key to the ON position. Observe the two LEDs mounted on the end of the Banks EconoMind Diesel Tuner:

- A steady GREEN LED will illuminate if all wire connections are correct, the engine is running, and the engine coolant temperature is within its normal operating range.
- The GREEN LED will flash if all wire connections are correct, the engine

is running, but the engine coolant temperature is not within its normal operating range. The GREEN LED will stop flashing once the engine coolant temperature is within its normal operating range.

- No LEDs will illuminate if the fuse on the EconoMind wiring harness is blown or the wiring harness is not properly connected. If the fuse and all connections are okay, contact Banks Technical Service.
- The RED LED will flash in a certain sequence if a connection is incorrect or if there is a problem with the system – this sequence will identify one or more diagnostic codes. A Banks EconoMind Diesel Tuner's diagnostic code is comprised of 2 digits. Each code is expressed in a sequence of 2 sets of the flashing red LED separated by a brief flashing of the green LED in between. Each set of a number of red LED flashes represents a digit. A longer flashing of the green LED separates the sequences. The LEDs will continue

to flash to display all the errors, and then repeat. **Table 1** lists the common diagnostic codes. For example, if a faulty thermocouple is detected (code "2,3") by the Banks EconoMind Diesel Tuner, the following red and green LED flashing sequence is observed when the key is on:

- (1) Two times flashing RED LED
- (2) One time quick flashing GREEN LED
- (3) Three times flashing RED LED
- (4) One time longer flashing GREEN LED

The above flashing sequence will repeat continuously. When the problem is corrected, the diagnostic code will be eliminated and replaced by a steady green light.

NOTE: If multiple codes are set, they will be displayed in a series separated by the longer flashing green LED. When reading codes, make sure to watch the entire series until you see the first code repeat.

-END, SECTION 10-

Section 11

CLEARING LEARNED PARAMETERS

If the Banks EconoMind Diesel Tuner has been moved to a different vehicle, or you are instructed to do so by Banks Technical Staff, it is possible to reset all of the parameters that the EconoMind has 'learned'.

CAUTION: The following procedures can only be carried out with the engine OFF!

1. Turn the vehicle key to ON but **DO NOT** start the engine.

2. Fully depress the throttle pedal and then release it completely. Repeat 5 times. The GREEN LED will flash when this is completed successfully.

3. Turn the key OFF. Wait 30 seconds, or until the GREEN LED goes

off and stays off. Turn the key back to the ON position but **DO NOT** start the engine.

4. Fully depress the throttle pedal and then release it completely. Repeat 5 times

-END, SECTION 11-

Section 12

REMOVAL OF THE ECONOMIND DIESEL TUNER

If the Banks EconoMind Diesel Tuner should ever need to be removed from the vehicle, perform the following:

- 1.** Disconnect the EconoMind's 38-pin connector from the factory harness.
- 2.** Re-connect the vehicle's 38-pin connector back into the factory harness.

3. Disconnect the EconoMind's 24-pin connector from the factory harness.

4. Re-connect the vehicle's 24-pin connector back into the factory harness.

5. Disconnect the 2-ring terminals from the EGT thermocouple.

6. Disconnect the 3 small connectors on the 'In-Cab Cable' and gently pull the cable back through the firewall.

7. Remove the Banks EconoMind Diesel Tuner.

Note: Failure to follow the above instructions when removing the module will result in a "Check Engine" light on the dash and a Diagnostic Trouble Code being stored in the factory computer, in addition to the engine not running.

-END, SECTION 12-

Section 13

AIR FILTER CLEANING INSTRUCTIONS

OILED AIR FILTER ONLY

NOTICE: The Banks Ram-Air Oiled Air Filter comes pre-oiled and no oiling is necessary for initial installation. Use Banks Ram-Air Filter Cleaning System (part#90094), available from Gale Banks Engineering to service the Air Filter. Follow the instructions included with the cleaning system to clean and re-oil your Bank Ram-Air Oiled Air Filter.

1. PRE-CLEANING

Tap the element to dislodge any large embedded dirt, then gently brush with a soft bristle brush. *NOTE: If complete cleaning is not practical at this time, reoil the element and reinstall in your vehicle.*

2. SPRAY-ON CLEANING

Spray air-filter cleaner liberally onto the entire element and let soak for 10 minutes.

3. PAN CLEANING

Large air-filter elements can be rolled or soaked in a shallow pan of air-filter cleaner. Remove immediately and let soak for approximately 10 minutes.

NOTICE: NEVER use gasoline, steam, caustic solutions, strong detergents, high-pressure nozzles, or cleaning solvents to clean the filter element. All of these can cause harm to the filter media as well as SHRINK and HARDEN the rubber end caps.

4. RINSING

Rinse off the element with low-pressure water. Tap water is okay. Always flush from the clean side to dirty side. This removes the dirt and does not drive it into the filter.

5. DRYING

Always dry naturally. After rinsing, shake off all excess water and let the element dry naturally.

6. AEROSOL OILING

After cleaning air filter always reoil before using. Spray air filter oil down into each pleat with one pass per pleat. Wait 10 minutes and re-oil any white spots still showing.

7. OILING HINTS

Never use a Banks Ram-Air filter without oil (the filter will not stop the dirt without the oil). Use only air filter oil. Air-filter oil is a compound of mineral and animal oil blended

with special polymers to form a very efficient tack barrier. Red dye is added to show just where you have applied the oil. Eventually the red color will fade but the oil will remain and filter the air. NEVER USE Automatic Transmission Fluid. NEVER USE Motor Oil. NEVER USE Diesel Fuel. NEVER USE WD40, LPS, or other light-weight oils.

8. REINSTALL

Reinstall your Banks Ram-Air filter element with proper care. Make sure the element seats properly in the filter case. Install the cover making sure it's in the right position. Tighten all the nuts, bolts, screws or clips to factory specifications.

9. DO NOT DISCARD

Affix the "Do Not Discard" sticker to the filter case (included with every Banks replacement element). Make sure you put the sticker in a highly visible place to alert your mechanic not to discard.

10. PERFORMANCE HINTS

Service every 50-100,000 miles on street-driven applications. Service more often in offroad or heavy-dust conditions. If an air-filter restriction gauge is installed, then change the element when the air-filter restriction reaches 18"-H.O.

CAUTION: Extremely fine dust from agriculture or offroad use will pull the oil from the element. Frequent reoiling of the element's clean side might be required. Completely service when practicable. For extra protection use an air-filter sealing grease on rubber ends of the element. Service only with air-filter cleaner and air-filter oil.

DRY FILTER CLEANING

Clean every 50-100,000 miles on street-driven applications. Clean more often in offroad or heavy-dust conditions. If an air-filter restriction gauge is installed, then change the element when the air-filter restriction reaches 18"-H.O.

1. PRE-CLEANING

Carefully tap the air filter element to dislodge any large embedded dirt or debris.

2. CLEANING

Spray an appropriate DRY AIR-FILTER

CLEANER SOLUTION liberally onto both sides of the entire filter element with the majority applied to the dirty side. Soak for 10 minutes. Do not allow the DRY AIR-FILTER CLEANER SOLUTION to dry on the air filter.

NOTICE: NEVER use gasoline, steam, caustic solutions, strong detergents, high-pressure nozzles, or cleaning solvents to clean the filter element. All of these can cause harm to the filter media as well as SHRINK and HARDEN the rubber end caps.

3. RINSING

Rinse the filter element with cool or warm (not hot) water from the clean side out in order to flush the dirt out of the filter. It may be necessary to use your fingers on the hose to apply light water pressure. Repeat steps 2 and 3, until the water flowing through the media is completely clear of any dirt and debris.

5. DRYING

After rinsing, gently shake off excessive water and allow to dry naturally. Re-install the filter onto the intake system, airbox or custom assembly once it is dry or just slightly damp. Follow all original installation instructions.

6. REINSTALL

Reinstall your Banks Ram-Air filter element with proper care. Make sure the element seats properly in the filter case. Install the cover making sure it's in the right position. Tighten all the nuts, bolts, screws or clips to factory specifications.

7. DO NOT DISCARD

Affix the "Do Not Discard" sticker to the filter case (included with every Banks replacement element). Make sure you put the sticker in a highly visible place to alert your mechanic not to discard.

8. PERFORMANCE HINTS

Service every 50-100,000 miles on street-driven applications. Service more often in offroad or heavy-dust conditions. If an air-filter restriction gauge is installed, then change the element when the air-filter restriction reaches 18"-H.O.

-END, SECTION 13-

Section 14

PLACEMENT OF THE BANKS POWER DECALS

Figure 54

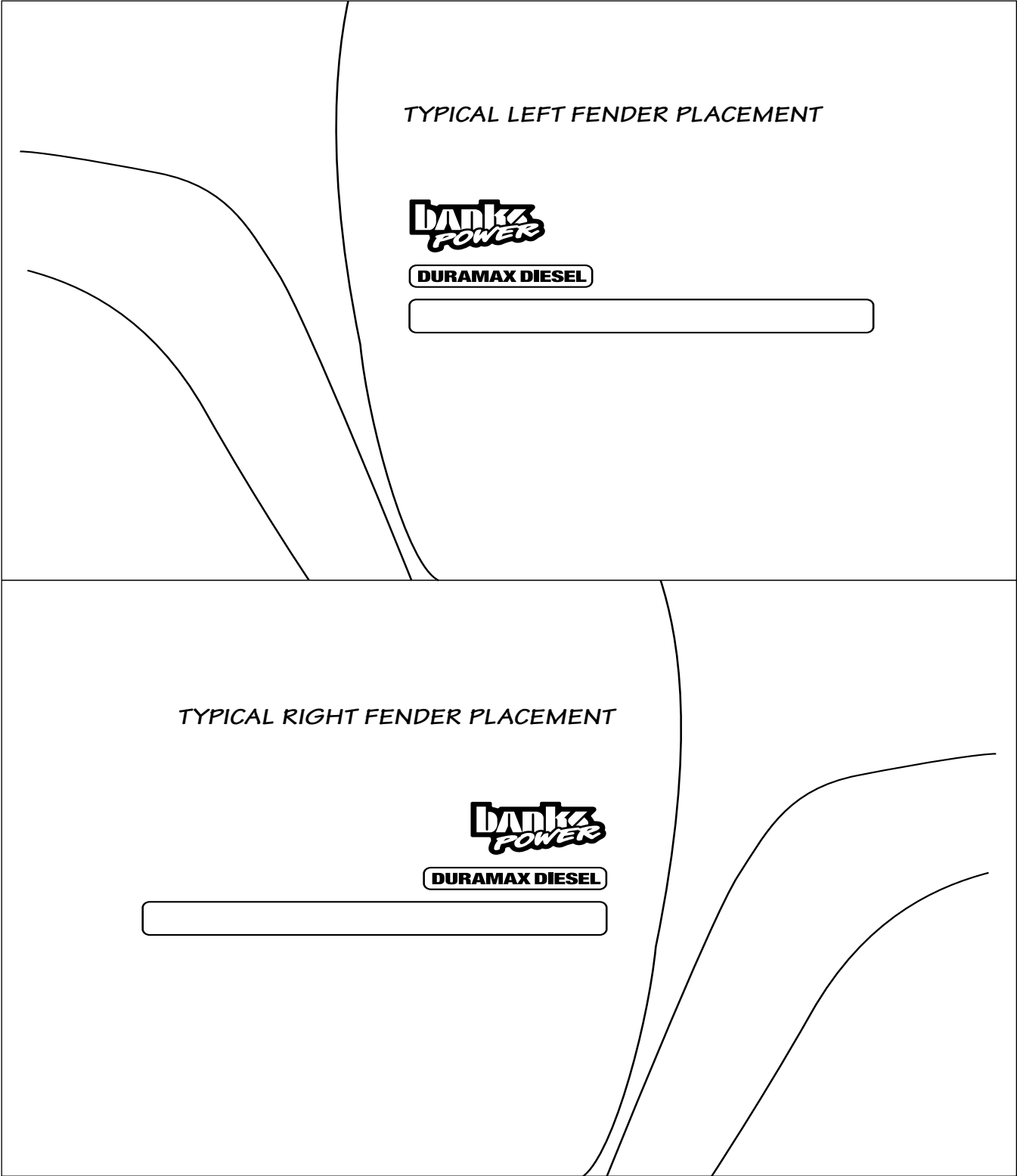

Figure 55 Trim template for the air box-mounting bracket.

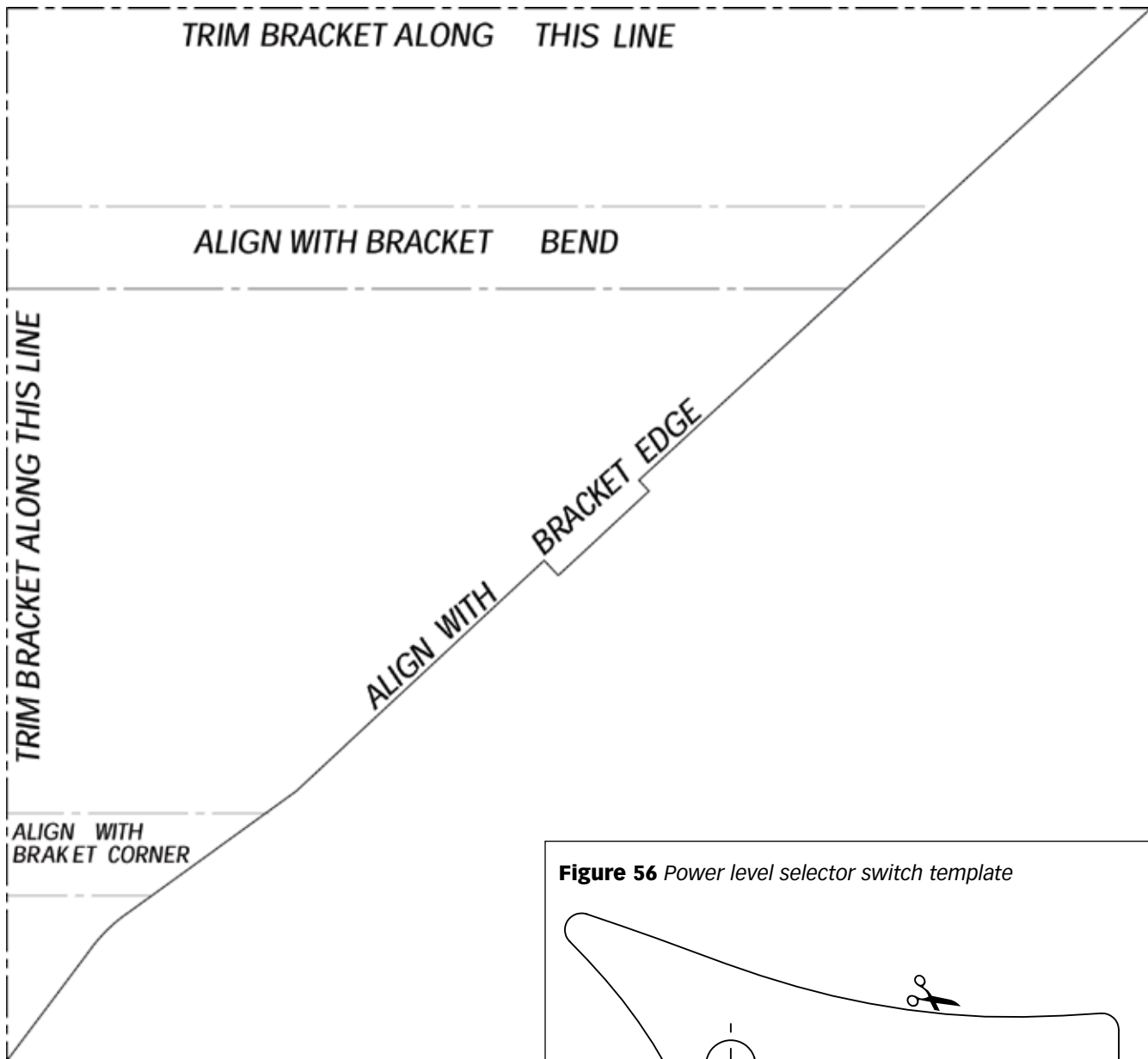
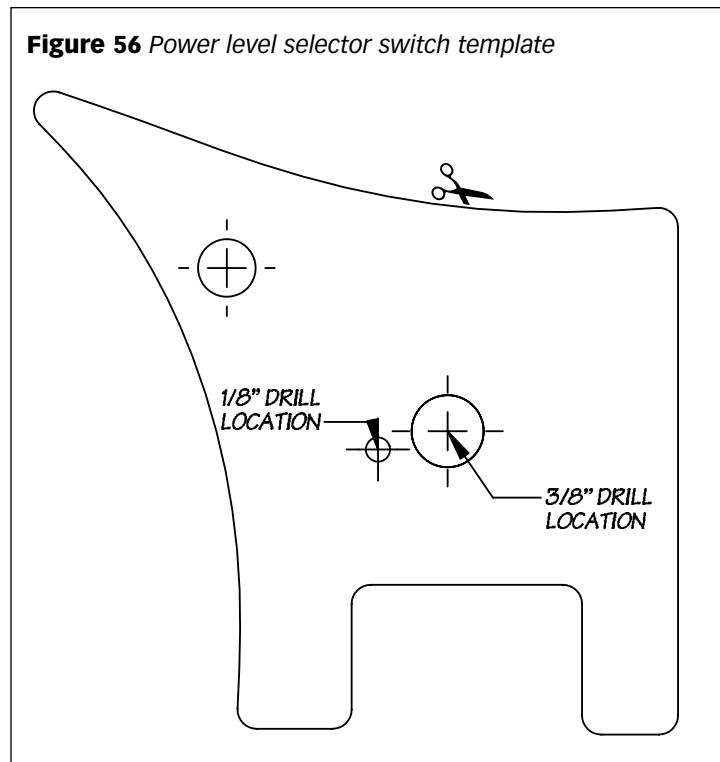

Figure 56 Power level selector switch template



Gale Banks Engineering
546 Duggan Avenue • Azusa, CA 91702
(626) 969-9600 • Fax (626) 334-1743

Product Information & Sales: (888) 635-4565
Customer Support: (888) 839-5600
Installation Support: (888) 839-2700

bankpower.com