



# FILTERS

## COLD AIR INTAKE

### INSTALLATION INSTRUCTIONS:

P/N: 75-5126/75-5126D





# FILTERS

**BREATHE EASY. YOUR ENGINE & WARRANTY ARE PROTECTED.™**

**Thank You!** for purchasing your new S&B Filters Intake Kit. If at any time you need additional assistance with installation or have any other questions or comments, feel free to call our customer service department at 909-947-0015. You can also take advantage of our live chat at [www.sbfilters.com](http://www.sbfilters.com) and connect with an S&B representative immediately. We hope you enjoy your new S&B Filters product and thank you for your continued support. Breathe Easy. Your Engine and Warranty Are Protected.

## VEHICLE APPLICATION:

**YEAR:** 2018

**MAKE:** Ford

**MODEL:** F-150

**ENGINE:** 3.0 Powerstroke Diesel

**APPROX. INSTALL TIME:** 1HRS | 00MIN

## TOOLS REQUIRED:

- 10 & 13mm Socket or Wrench
- Flat Blade Screwdriver
- Philips Screwdriver
- T20 Torx
- Utility Knife
- 5/16" Nut Driver (optional)
- Panel Popper (optional)
- Flush Diagonal Cutter (optional)

## NOTES:

Kit may not fit with the following Aftermarket Parts installed:

- Body Lift or Lowering Kit
- Custom Hood
- Aftermarket Turbocharger

## CARB STATUS - PENDING

Product will be submitted to Air Resources Board for approval shortly.

*Not Legal for use in CA or other states adopting CA emissions standards"  
See Page 2 for more info.*

## S&B FILTER MAINTENANCE:

- Cotton Cleanable (KF-1058). If the enclosed filter is Red it is a Cotton Cleanable filter and came preoiled from our factory. Please visit [www.sbfilters.com](http://www.sbfilters.com) and search the filter part number to find the correct quantity of oil to use when cleaning your filter.
- Dry Extendable (KF-1058D). If the enclosed filter is White it is a Dry Extendable filter and should be discarded once it reaches capacity. This filter does not require oil, do not wash or oil this filter.

## BEFORE YOU START

- Please read the entire product guide before proceeding.
- Ensure all components listed on pages 3 & 4 are present.
- If you are missing any of the components, call our customer support at (909) 947-0015.
- Do not work on your vehicle while engine is hot.
- Make sure the engine is turned off and the vehicle is in Park or the Parking Brake is set.

## WARNINGS

### Warning!

If your vehicle has a Vehicle Emission Control Information decal affixed to the factory airbox, a new replacement label must be obtained and installed in a readily visible position in the engine compartment in order to remain CARB compliant. Failure to do so will prevent the vehicle from passing a smog check. Replacement labels can be ordered from your local dealership. Regulations state that the VECI label shall not be affixed to any equipment which is easily detached from the vehicle. Label placement, under the hood on a painted surface is recommended.



### Operation in Snow and Rain

If you are driving in heavy snowfall or extreme rain conditions, you should always check for accumulated snow and water on the air filter following your OE recommendations for driving in these conditions.

The following is recommended after operating the vehicle up to 100 miles in heavy snowfall or extreme rain: At the earliest opportunity, open the hood and check the air box and filter. If any snow has accumulated, make sure to remove the snow from the filter, box, and inlet. It is okay if the filter is a little wet. Wet filters will normally dry out on their own. If the filter is dripping wet, it should be replaced with another filter that is not wet. Do not reuse the dripping wet filter until it has naturally dried.

## GENERAL INFORMATION

### Performance Testing

- After your installation is complete engage parking brake and start your engine. Listen for abnormal noises. If an air leak is detected, re-inspect hoses and connections as they may need to be repositioned and tightened.
- S&B FILTERS recommends that you keep your OE intake system in the event it is required in the future.
- In order to maintain your warranty, all connections and components must be checked periodically for alignment and for proper tension on all connections. Failure to do so may void your warranty.
- Use only S&B FILTERS cleaning and oil products to service your filter. Using any other brand oil and/or cleaners on your S&B air filter may void your warranty.

### Emissions Standard

The California Air Resource Board (CARB) requires that an E.O. Identification label be applied to the vehicle in order to pass a smog check inspection when a Performance Intake Kit has been installed. You must place the E.O. Label provided on or near the intake kit after installation so that a smog check technician can easily verify the E.O. Number. Check the status of the exemption process by looking up a specific part number at [www.sbfilters.com](http://www.sbfilters.com). The CARB Exemption number and/or status is listed under the Product Details section for each part number. If the status shows as "Pending," CARB has yet to issue an exemption but the product has been submitted. Products that have not been issued an E.O. number are street legal in most states, but may not be used on emission controlled vehicles in the state of California and are for off road use only. If you purchased your kit from S&B Filters directly, or an authorized S&B Filters Dealer, email [customerservice@sbfilters.com](mailto:customerservice@sbfilters.com) with a photo of your intake and your mailing address so we can mail you an Exemption Sticker.

**EXPLODED VIEW:**

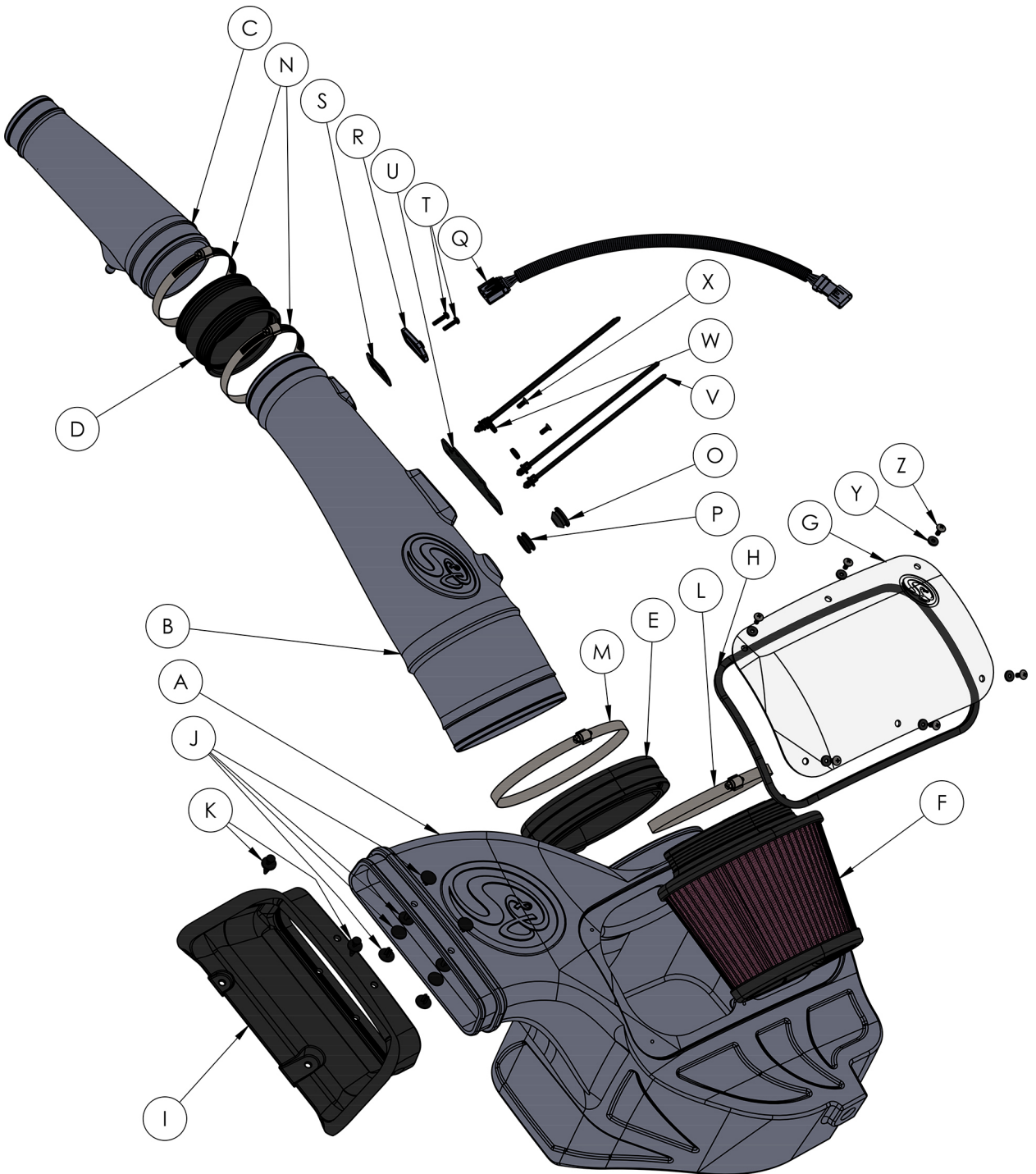

## PARTS LIST: 75-5126

ITEM	QTY	DESCRIPTION	PART NUMBER
A	1	INTAKE AIR BOX	AL1246B-00
B	1	LARGE INTAKE TUBE	AL1341-00
C	1	SMALL INTAKE TUBE	AL1341A-00
D	1	SILICONE COUPLER	AI1714C-00
E	1	SILICONE CUFF	AI1604C-00
F	1	FILTER	KF-1058
G	1	CLEAR LID	AI1760-00
H	1	LID SEAL	AI1636-07
I	1	FRONT INLET	AI1758C-00
J	8	PLASTIC RIVET, INTERLOCKING SHANK	AI1762-00
K	2	PLASTIC RIVET, PUSH LOCK	AI1763-00
L	1	#88 HOSE CLAMP	AG1011-00
M	1	#104 HOSE CLAMP	AG1012-00
N	2	#64 HOSE CLAMP	AG1018-00
O	1	FILTER MINDER PLUG	AI1705-00
P	1	FILTER MINDER GROMMET	AI1563-00
Q	1	MAF EXTENSION HARNESS	AI1481-00
R	1	MAF MOUNT	AI1822-00
S	1	MAF GASKET	AI1823-00
T	2	SCREW, 8-32 X 3/4"	AI1837-00
U	1	WIRE HARNESS BRACKET	AI2140-00
V	4	PUSH IN MOUNT CABLE TIE	AI2154-00
W	2	WASHER	AI2057-00
X	2	SCREW, 10-24 X 1/2"	AI2005-00
Y	6	WASHER	AI1540-00
Z	6	TRUSS HEAD SCREW, 10-24 X 1/2"	AI1539-00

HARDWARE PACKS
HP1595-00
AE2024-00
AG1012-00
AG1018-00
AI2154-00
AI2154-00
HP1374-00
AI1563-00
AI1763-00
AI1762-00
HP1597-00
AI2057-00
AI2005-00
AI1705-00
AI2140-00
HP1375-00
AI1539-00
AI1540-00
HP1596-00
AI1760-00
AI1636-07

AM0454-00 12/04/2018



## INSTALLATION STEPS:

- 1** Disconnect the negative battery cable by loosening the terminal clamp and removing it from the battery post. **Note:** Failure to disconnect the battery for a minimum of 2 hours may cause the Check Engine Light to illuminate after installation.  
**Tool Needed:** 10mm Socket or Wrench

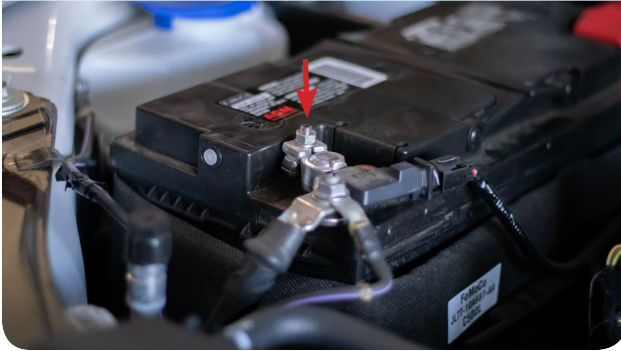

- 2** Loosen the hose clamp connecting the intake tube to the stock air box, then pull the intake tube off of the air box.  
**Tool Needed:** Flathead Screwdriver

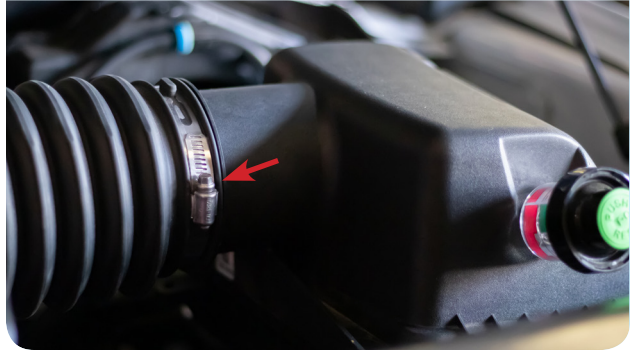

- 3** Disconnect the MAF sensor wire harness. First pull the red locking tab out, press down on the plug retaining tab to release it, then pull the plug apart.

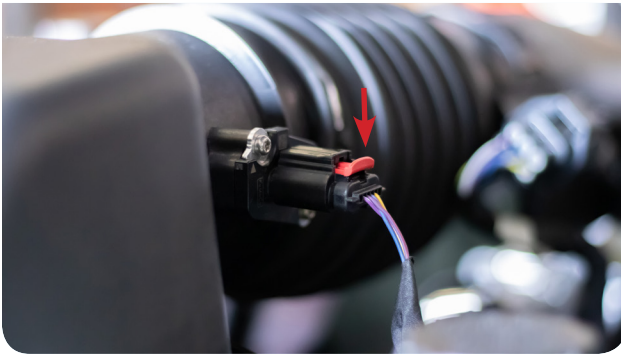

- 4** Unlatch the two latches holding the stock air box lid onto the stock air box.



- 5** Lift and remove the stock air box lid and air filter from the vehicle.



- 6** Remove the single retaining bolt attaching the stock air box to the fender. Set the bolt aside, it will be reused in Step 28.  
**Tool Needed:** 13mm Socket or Wrench



**7** Remove the metal bushing from the stock air box pulling it from the inside. Set the metal bushing aside, it will be reused in Step 17.



**8** Remove the grommet from the stock air box by pulling up. Set the grommet aside, it will be reused in Step 16.



**9** Disconnect any harness clips attached to the stock air box.  
**Tool Needed:** Flathead Screwdriver or Panel Popper.

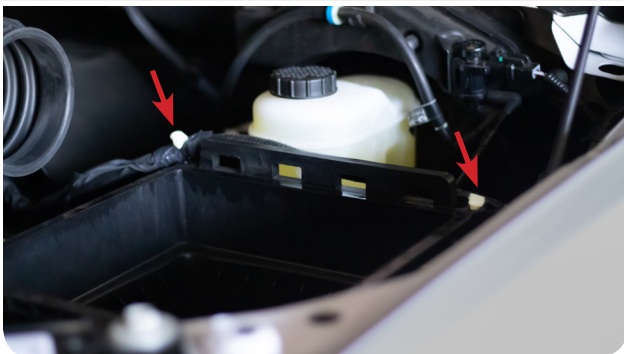

**10** Remove the plastic rivets on the stock air scoop using a flat head screwdriver. First pop the center up to unlock the rivet, then remove the complete rivet.  
**Tool Needed:** Flathead Screwdriver

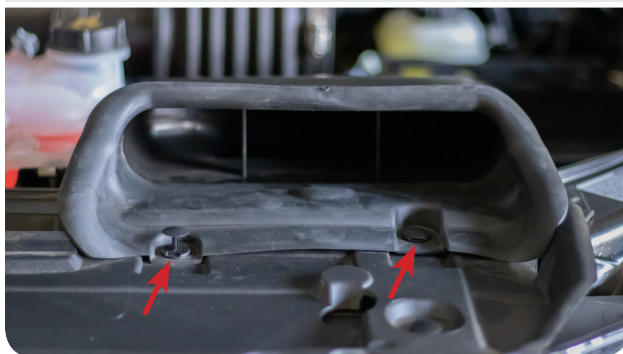

**11** Lift and remove the stock air box from the vehicle.



**12** Completely loosen the hose clamp connecting the stock intake tube to the turbo inlet tube.  
**Tool Needed:** Flathead Screwdriver





## INSTALLATION STEPS:

- 13** Remove the wire harness strap from the stock intake tube by unclipping the strap.  
**Tool Needed:** Flathead Screwdriver



- 14** Remove the harness plug and wire clips from the harness strap. Pry the plug retaining tab up to release it, then slide the plug off of the harness strap.  
**Tool Needed:** Flathead Screwdriver or Panel Popper

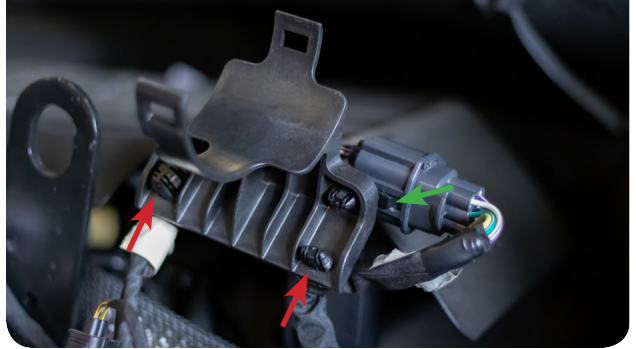

- 15** Remove the stock intake tube from the vehicle.

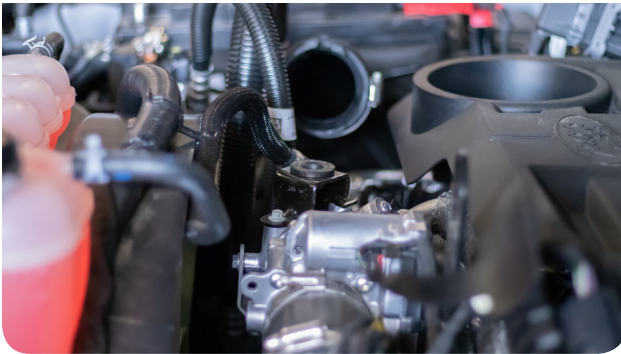

- 16** Install the grommet removed in Step 8 into the S&B Air Box (A).



- 17** Install the the metal bushing removed in Step 7 into the grommet by pressing it in from inside the Air Box.



- 18** Install the Rubber Cuff (E) and Hose Clamp (M) onto the side of the S&B Air Box. Make sure that the rubber pull tab on the Cuff is on the bottom. Tighten the hose clamp just enough to hold the Cuff in place.  
**Tool Needed:** Flathead Screwdriver or 5/16" Nut Driver





**19** Install the Front Inlet (I) onto the S&B Air Box. Use 2 of the supplied Plastic Rivets (J) on each hole, pinching them together tightly to lock them in place.



**20** Remove the MAF sensor retaining screws and the MAF sensor from the stock air box lid.  
**Tool Needed:** T20 Torx



**21** Install the MAF sensor onto the Large Intake Tube (B), using the provided MAF Mount (R), MAF Gasket (S), and Screws (T).  
**Tool Needed:** Philips Screwdriver



**22** Install the Coupler (D) and 2 Hose Clamps (N) onto the Large Intake Tube. Do not tighten the Hose Clamps.



**23** Install the Wire Harness Bracket (U) onto the Large Intake Tube, using the the Screws (X) and Washers (W).  
**Tool Needed:** Philips Screwdriver

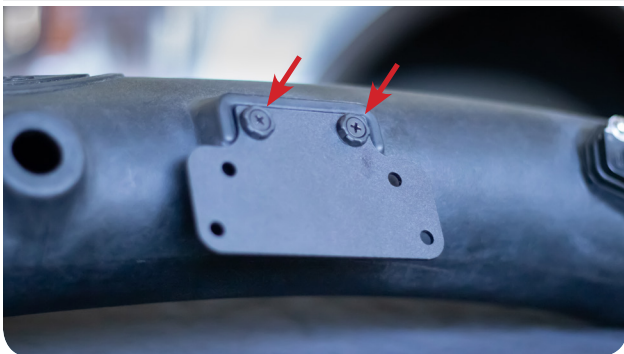

**24** Install the Push In Cable Ties (V) into the 4 holes in the bracket.

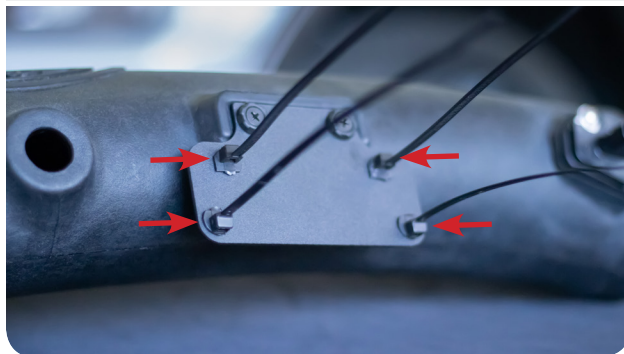

## INSTALLATION STEPS:

- 25** S&B recommends regular visual inspections of your new filter to best assess the status of the filter. If you choose not to use the stock Filter Minder, install the supplied Plug (O).



- 26** If you choose to use the stock Filter Minder install the Grommet (P) then install the Filter Minder. Remember to inspect your filter on a regular basis to ensure it is properly maintained.



- 27** Install the S&B Air Box by aligning the box prongs with the factory grommets and pushing the air box down firmly to ensure that the prongs are completely seated in the grommets.



- 28** Reinstall the retaining bolt removed in Step 6, tighten it securing the S&B Air Box to the inner fender.  
**Tool Needed:** 13mm Socket or Wrench

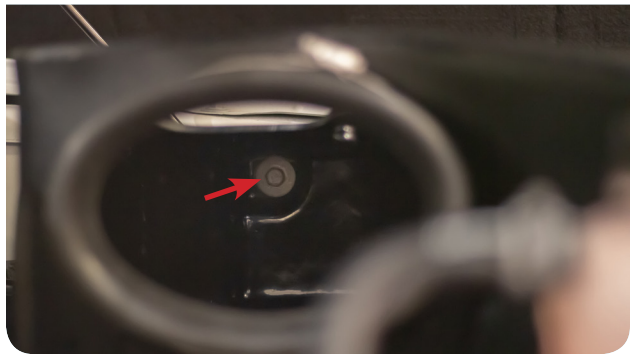

- 29** Place the Air Filter (F) with Hose Clamp (L) inside the S&B Air Box. Turn the filter sideways, squeeze the silicone flange slightly, and slide it into the air box. Be careful not to damage the filter pleats on the lid mounting tabs.



- 30** Feed the Large Intake Tube through the Rubber Cuff on the S&B Air Box.





- 31** Slide the Air Filter over the Large Intake Tube until the tube bottoms out on the step on the inside of the filter flange, then tighten the Hose Clamp.  
**Tool Needed:** Flathead Screwdriver or 5/16" Nut Driver



- 32** Install the larger end of the Small Intake Tube (C) into the Coupler on the Large Intake Tube.

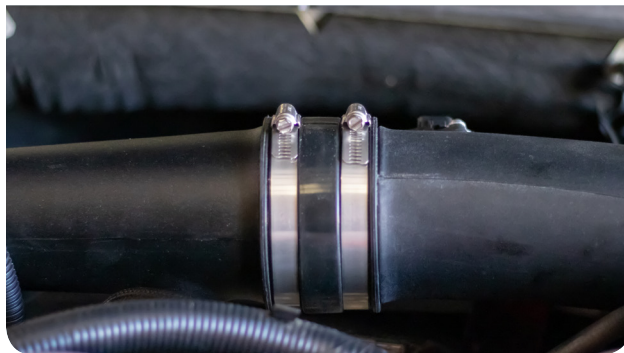

- 33** Install the smaller end of the Small Intake Tube into the coupler on the stock turbo inlet tube. Adjust the tube so the prong rests in factory grommet and tighten the hose clamp.  
**Tool Needed:** Flathead Screwdriver



- 34** Press the Large Intake Tube firmly against the Air Box Cuff and tighten the 2 hose clamps on the coupler connecting the 2 intake tubes.  
**Tool Needed:** Flathead Screwdriver or 5/16" Nut Driver

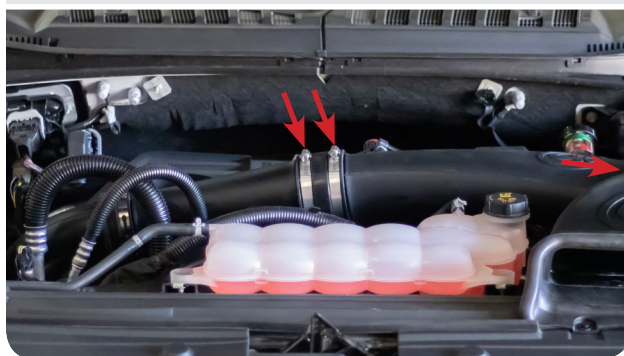

- 35** Insert the harness clips removed in Step 9 into the holes on the side of the S&B Air Box.



- 36** Connect the MAF Extension Harness (Q) between stock MAF harness and the MAF sensor.



## INSTALLATION STEPS:

- 37** Use the Push In Cable Ties to secure the MAF Extension Harness and the harness wires that were removed from the wire harness strap. Keep the wires away from any hot surfaces that could damage them.  
**Tool Needed:** Utility Knife or Flush Diagonal Cutter



- 38** Secure the Front Inlet to the vehicle by inserting the Plastic Rivets (K) into the holes and firmly pushing down on the rivet center pin until it locks in the down position. **Pull up on the Front Inlet to confirm it is securely attached.**

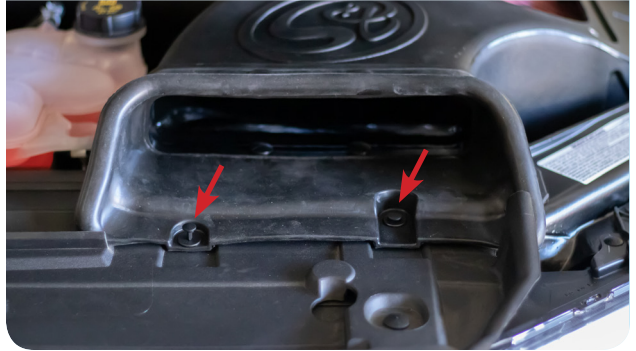

- 39** Remove the protective covering from the Clear Lid (G) and S&B Logo.



- 40** Install the Lid Seal (H) on the Clear Lid.



- 41** Install the Clear Lid on top of the S&B Air Box and secure the lid using the six Screws (Z) and Washers (Y). Do not over tighten.  
**Tool Needed:** Phillips Screwdriver



- 42** Reconnect the negative terminal on the battery and tighten.  
**Tool Needed:** 10mm Socket or Wrench





**43** Inspect your installation, make sure the kit is properly positioned and all fasteners are secure. The installation is now complete.



## RELATED ITEMS FOR YOUR PURCHASE

Order Online today at [www.sbfilters.com](http://www.sbfilters.com) or through your local S&B distributor.



**Cotton Cleanable Filter**  
SKU# KF-1058



**Dry Extendable Filter**  
SKU# KF-1058D



**Precision II Cleaning Kit**  
SKU# 88-0008