



INSTALLATION INSTRUCTIONS

PART NUMBER: 6000817

VEHICLE MAKE: GM

MODEL: GM2500 2WD/4WD W/ SINGLE REAR WHEELS

YEARS: 2020-2024

PRODUCT: BIG CLAW HD FRONT

REVISION: REVISION A

REVISION DATE: 8 APRIL, 2025

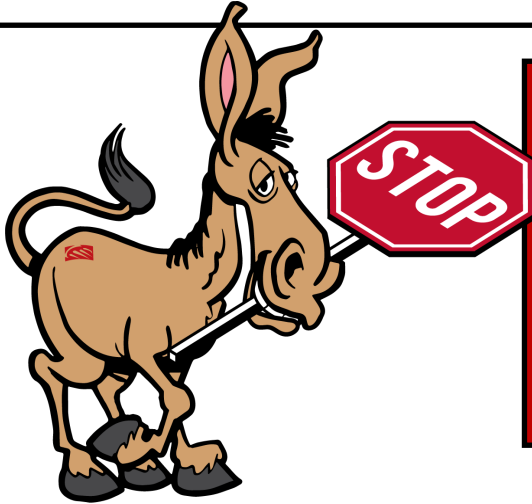

READ BEFORE CONTINUING!

Returns will not be accepted for ANY installed PART or ASSEMBLY. Use great care in preventing cosmetic damage when performing wheel fit check. If a product must be returned, please contact Baer customer service for an RMA number.

The recipient of this product indemnifies Baer Inc. for all liabilities or losses incurred in connection with the recipient modifying or altering Baer Inc. product during installation.

Notices – Read and Follow BEFORE ATTEMPTING INSTALLATION

- All installations require proper safety procedures and protective eyewear.
- All installations assume basic mechanical skill and a factory service manual for the vehicle on which the installation is to be performed.
- All references to the “left” side of the vehicle correlate to the driver’s side of the vehicle.
- Any installation requiring you to remove a wheel or gain access under the vehicle requires use of jack stands appropriate to the weight of the vehicle. In all cases, jack stands rated for a minimum of 2-tons is recommended.
- A selection of hand tools sufficient to engage in the installation of these products is assumed and is the responsibility of the installer to have in his/her possession prior to beginning this installation. All installations, which require removal of hydraulic hoses and/or bleeding of the brakes, require appropriate fitting/line wrenches, safety catch can, and protective eyewear. Other than these items, if unique or special tools are required, they will be stated appropriately in the installation step.
- ALWAYS CONFIRM WHEEL FIT BEFORE BEGINNING INSTALLATION OF ANY BRAKE SYSTEM OR “UPSIZED” ROTOR UPGRADE! In addition to checking wheel fitment of this system with the wheel fitment template (available online at www.Baer.com), always place the actual corner assembly or a combination of the caliper assembly on the rotor, and into the actual wheel with great care to prevent cosmetic damage. This procedure will reconfirm proper clearance between the caliper and the wheel before proceeding with the actual installation.
- Returns will **not** be accepted for systems that have been partially or completely installed. **Use extreme care when checking wheel fitment to prevent any cosmetic damage of brake components.** Wheel fitment should be verified before installation using a wheel fitment template supplied at www.Baer.com
- When installing new Baer rotor, be sure to follow the direction of rotation indicated on the rotor hat area with either an arrow, an “L” for left, or an “R” for right, or both. “L” always indicates the rotor for the driver side of US spec vehicles. Follow the rotor installation and rotation instructions included in the promo pack (P/N 6020502) included with your system when installing rotors. Failure to properly install rotors will not allow for proper function of the brake system and will cause heat related fatigue and failure.
- A professional wheel alignment is required for any system requiring the replacement of the front spindles or tie rod ends. Follow factory prescribed procedures and specifications unless otherwise indicated.



- Contact Baer technical support at 602.233.1411 if you are unsure that the brake system you ordered will work for your application based on the axle standoff you measured.
- Note: Baer recommends taking photos of the brake system before disassembly and during each step of the disassembly process. Photos may allow technical support to better assist given any necessary troubleshooting.**
- If anything becomes unclear or any parts require force to install at any point during the installation, stop immediately and consult directly with Baer technical staff. Please have these instructions and the part number of the components that is/are proving difficult to install. Please provide technical staff with the make, model, and year (date of vehicle production is preferred) of your vehicle. Baer's technical staff is available by phone (602.233.1411) or email (ContactUs@Baer.com) from 8:30 AM - 5:00 PM MST (Mountain Standard Time) Monday - Friday (Arizona does not observe Daylight Savings Time).

**REMOVAL OF FACTORY BRAKE COMPONENTS**

1. Carefully lift and support the front end of the vehicle. It is recommended to place chocks behind the rear wheels to prevent the vehicle from rolling during installation.
2. Remove the front wheels from the vehicle.
3. Unbolt the brake caliper body from the caliper bracket by removing the sliding pin bolts from the caliper assembly. **DO NOT** unbolt the brake hose from the caliper body, doing so will open the brake system and require you to bleed the brakes following installation. Set the sliding pin bolts to the side as they will be used to re-secure the caliper body to the new Big Claw HD anchor brackets.

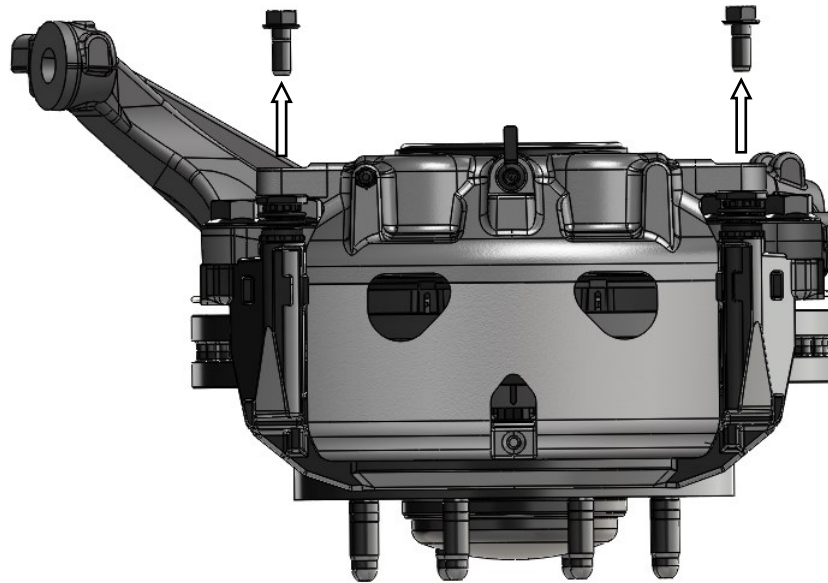

4. Carefully remove the factory caliper assembly from the factory anchor bracket and support the caliper assembly within the wheel well. **DO NOT** allow the caliper assembly to hang by the brake hose as it may damage the brake hose.

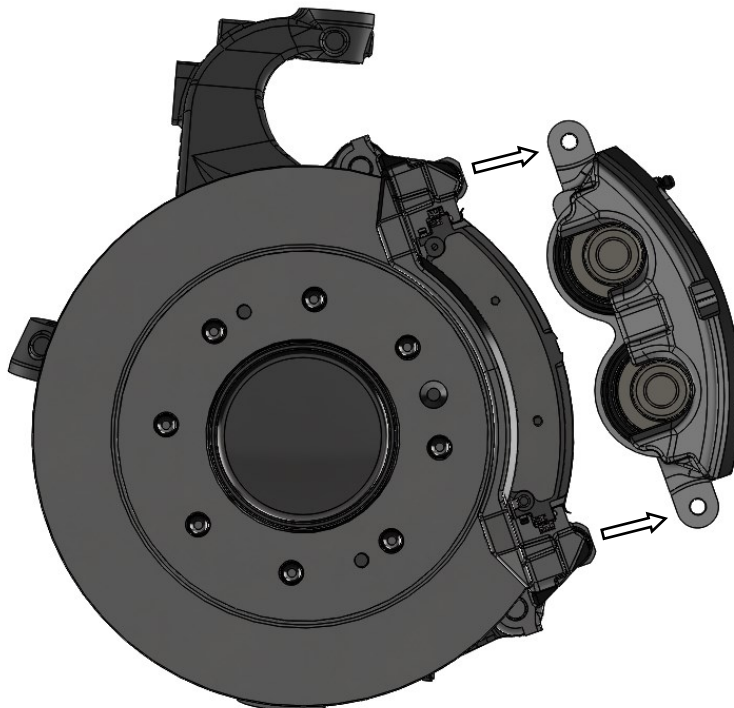

TUCK THE CALIPER ASSEMBLY WITHIN THE WHEEL WELL AND SUPPORT IT, DO NOT ALLOW IT TO HANG BY THE BRAKE HOSE AS IT MAY DAMAGE THE HOSE.

**REMOVAL OF FACTORY BRAKE COMPONENTS CONTINUED**

5. Unbolt and remove the caliper anchor bracket assembly from the vehicle and place on an adequate work platform to perform the next step. The factory caliper anchor brackets will not be used with any of the new brake components in this system, however it is recommended that they are stored for future safekeeping. Set the factory caliper anchor bracket mounting hardware to the side as it will be re-used to secure the new Big Claw HD caliper anchor brackets to the vehicle.

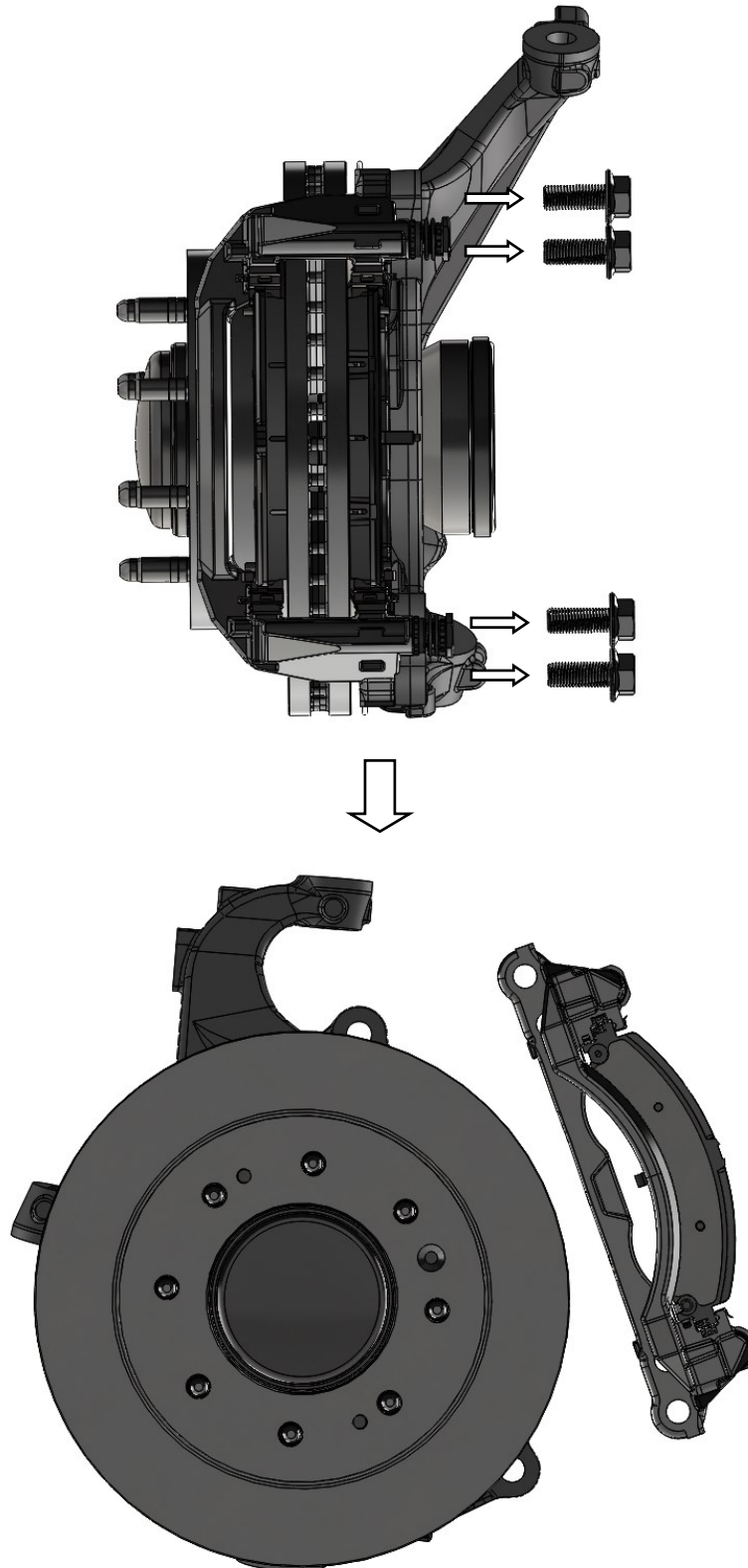



REMOVAL OF FACTORY BRAKE COMPONENTS CONTINUED

6. Carefully remove the pin sliders from the caliper anchor bracket.

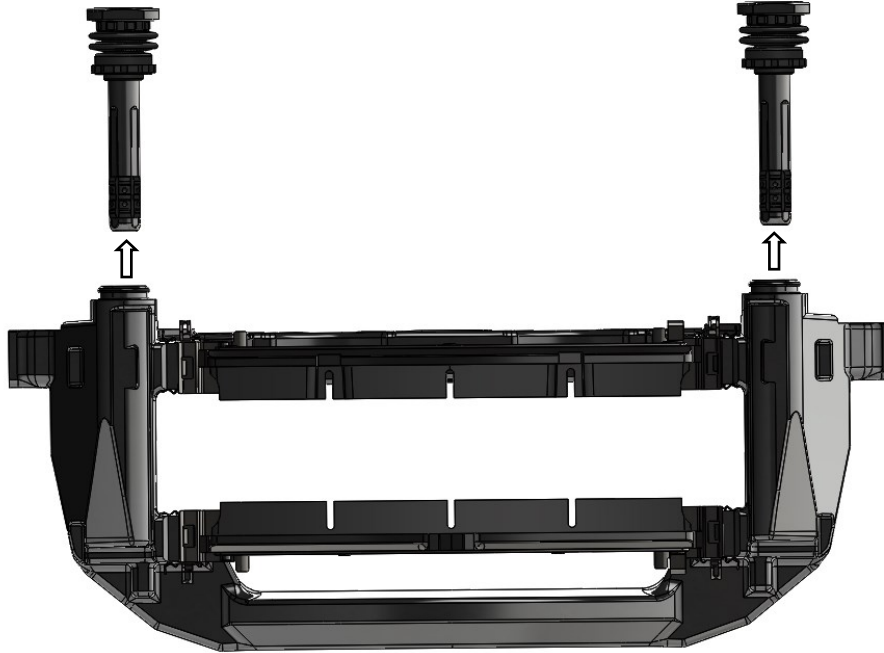

7. Carefully remove the brake pads from the caliper anchor bracket.

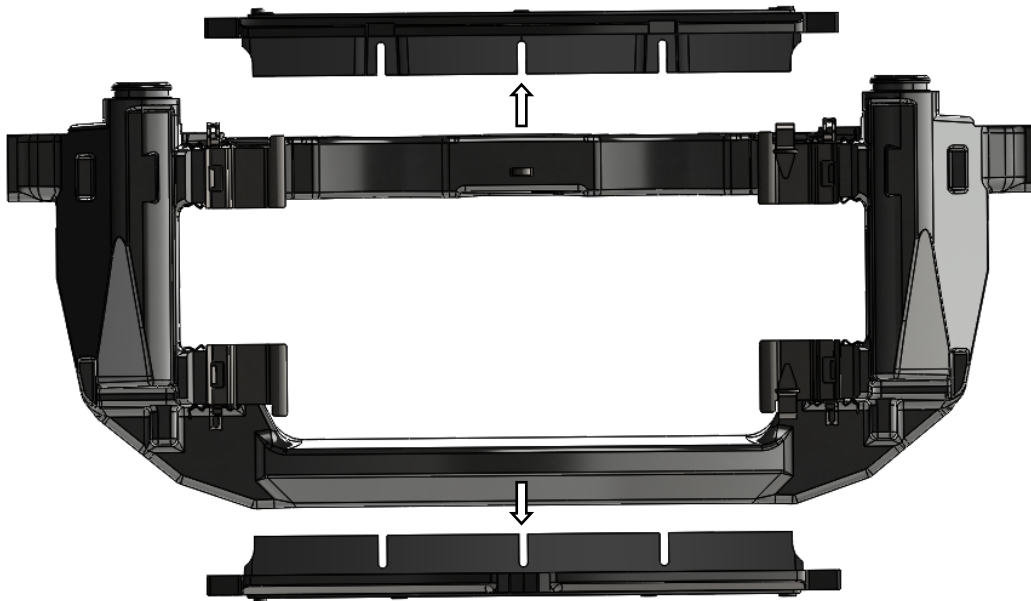



8. Carefully remove the brake pad abutment hardware from the caliper anchor bracket.

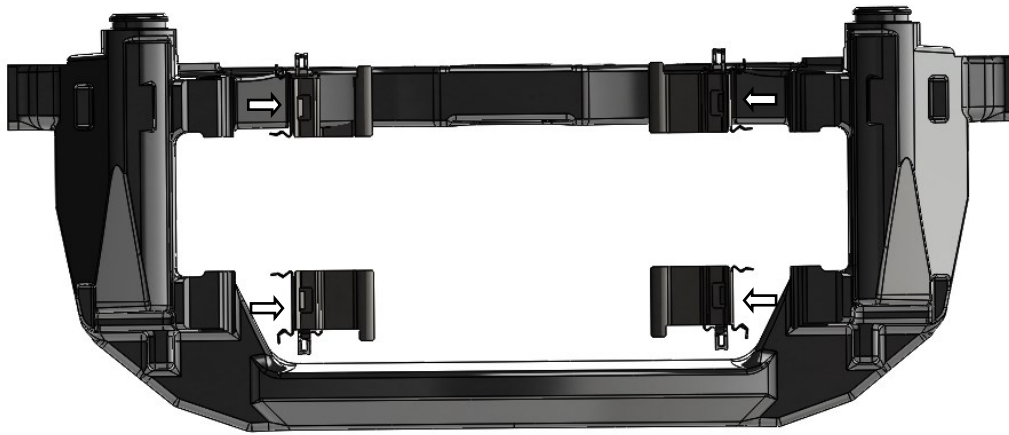

9. Remove the factory brake rotor from the wheel hub and carefully inspect the rotor mounting face of the wheel hub for debris/damage. Clean any debris present on the rotor mounting face of the wheel hub and replace any damaged wheel hub components as necessary.

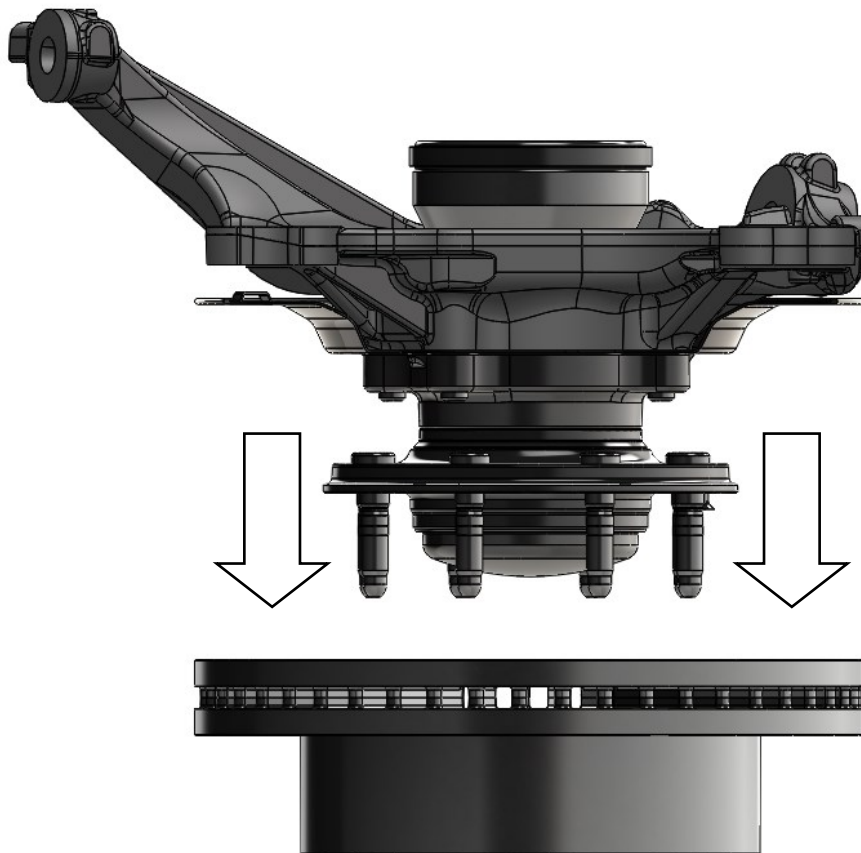

**BIG CLAW HD ANCHOR BRACKET PREPARATION**

1. It is recommended to install all of the necessary components into the new Big Claw anchor brackets before mounting them on the vehicle as it can be done easily on an adequate work platform/bench.
2. Clean the factory slide pins with warm water and dish soap to prevent damaging the pins.
3. Apply a thin, even coating of the supplied silicone grease to the now clean sliding pins.
4. Carefully install the sliding pins into the new Big Claw HD anchor brackets. **Clean your hands, or replace gloves if any lubricant residue is present to prevent contact with the friction surface of the new Big Claw HD rotors during installation.**
5. Install the factory abutment (brake pad) hardware to the Big Claw HD anchor brackets. The Big Claw HD anchor brackets were designed to use the factory abutment hardware, aftermarket hardware may require slight modification if used. This modification can typically be performed with a pair of pliers. Modify or bend abutment hardware as necessary to fit into the Big Claw HD anchor brackets.

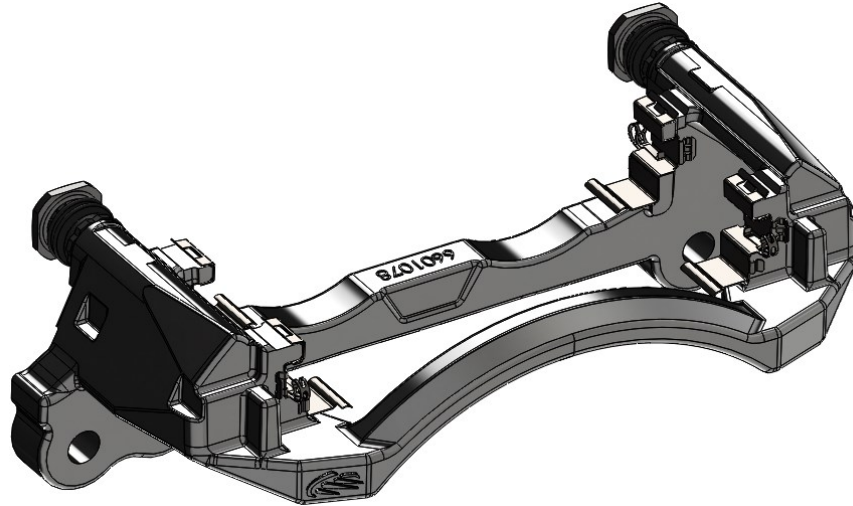
**BIG CLAW HD ROTOR INSTALLATION**

1. Install the correct side Big Claw HD rotor to the wheel hub and temporarily secure with two lug nuts. Refer to the "Rotor Direction & Installation" instructions contained within the promo packet provided with this system to ensure you install the correct side rotor. Left (driver's side) rotor shown below installed on the left (driver's) side knuckle.

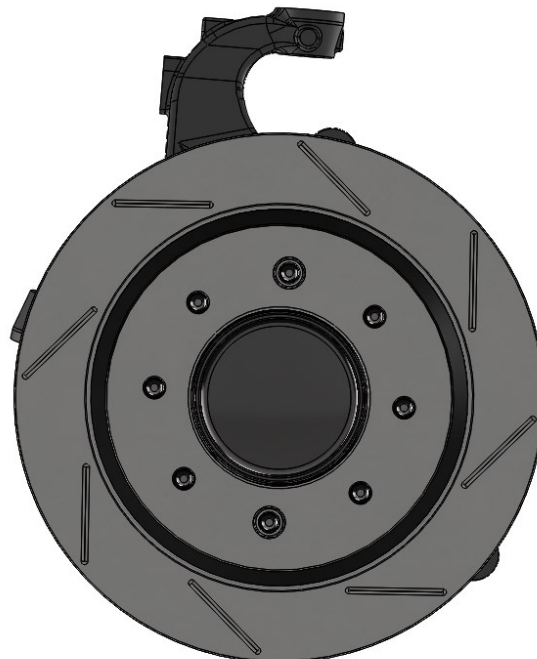

BIG CLAW HD ANCHOR BRACKET INSTALLATION

1. Install the prepared Big Claw HD anchor bracket to the knuckle and secure with the factory hardware. The Big Claw HD anchor bracket mounts to the knuckle in the same location as the factory anchor bracket.

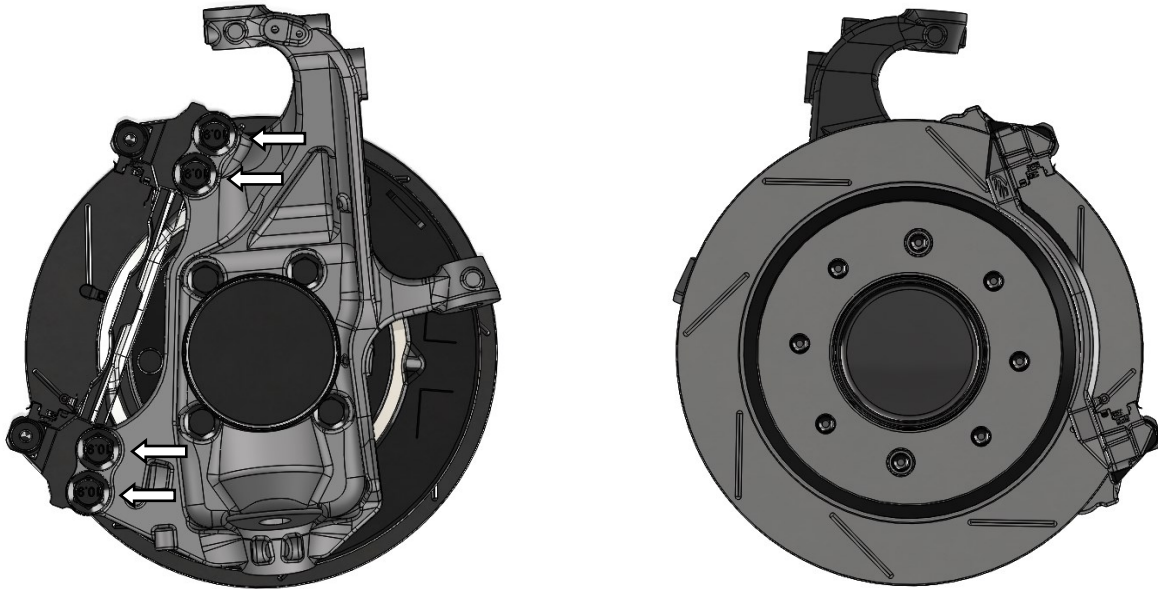

2. Torque the mounting hardware to the factory recommended torque spec to secure the prepared Big Claw HD anchor bracket to the knuckle.
3. Rotate the rotor multiple times to ensure there is no contact between the Big Claw HD anchor bracket and the rotor. The abutment hardware may contact the rotor as you rotate it. If this happens, the hardware can be bent away from the rotor with a set of pliers.
4. **Make sure no lubricant residue is present on the friction surface of the brake pads or rotor, this will significantly decrease performance of the brakes and potentially lead to harm or injury. If there is any lubricant residue present on the friction surface of the brake pads or rotor, properly clean said surface(s) with an appropriate brake clean product before installing on and operating the vehicle.**

CALIPER BODY INSTALLATION

1. Press the brake pads on the prepared Big Claw HD anchor bracket firmly against the rotor and reinstall the caliper body to the prepared Big Claw HD anchor bracket. **It should be noted that the caliper pistons will have to be retracted in order for the caliper body to be installed.**

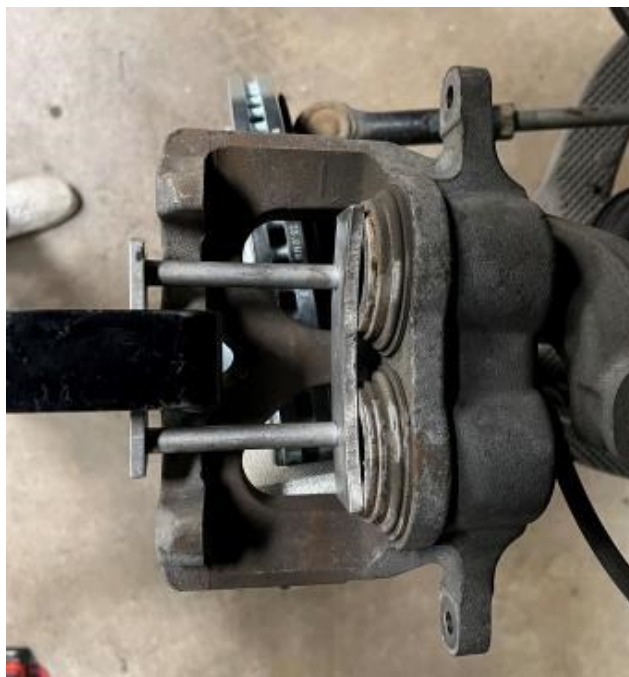

**CALIPER BODY INSTALLATION CONTINUED**

2. Install the caliper body to the Big Claw HD anchor bracket with the factory sliding pin bolts.

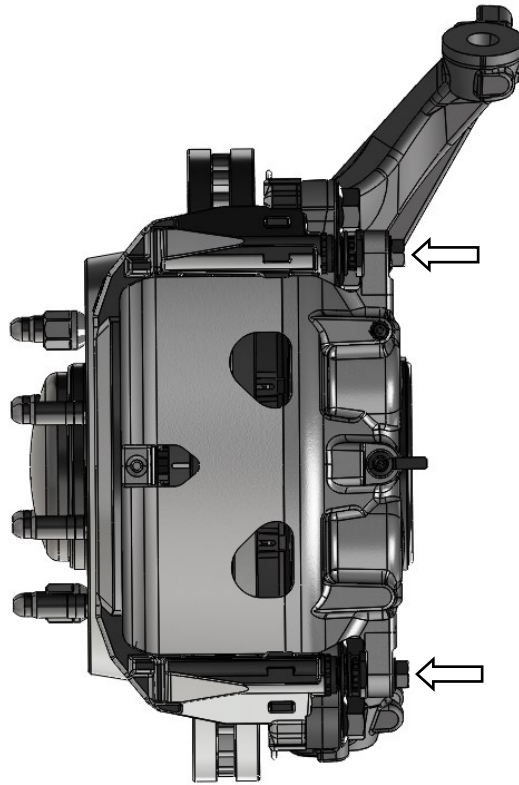

3. Torque the mounting hardware to the recommended factory torque spec to secure the caliper body to the prepared Big Claw HD anchor bracket.
4. Remove the two lug nuts that were previously used to temporarily secure the rotor to the wheel hub.
5. Reinstall the front wheels and torque the lug nuts to the factory torque spec to properly secure the wheels.
6. Refer to the "ROTOR SEASONING AND PAD BEDDING INSTRUCTIONS" contained within the promo packet provided with this system to ensure the rotors are properly seasoned and the brake pads are properly bedded for optimal braking performance.

NOTE: It is important to verify wheel fitment for spare wheels. This system is larger than the stock brake system and wheel fitment must be verified for spare wheels.

We at Baer understand there are many options when it comes to performance brake suppliers and appreciate your business. Great pride and care were taken in designing, assembling, and packaging all components of this brake system.

Thank you for your purchase.