



INSTALLATION INSTRUCTIONS

SUBJECT: ALLISON TRANSMISSION COOLER LINES FOR 2017-19 L5P DURAMAX

FPE-2022-78
August, 2022

FITMENT: 2017-2019 CHEVY/GMC LML pickup trucks with 6.6L Duramax and Allison Transmission

KIT P/N: FPE-TL-L5P-1719

ESTIMATED INSTALLATION TIME: 4 Hours

KIT CONTENTS:

| Item | Description | Qty |
|------|---|-----|
| 1 | 7/8"-14 O-ring to -10AN fitting | 6 |
| 2 | Large OD washer | 2 |
| 3 | Locking cable ties | 2 |
| 4 | Double hose clamps | 2 |
| 5 | Transmission cooler line – (short, Straight/90 deg) | 1 |
| 6 | Transmission cooler line – (medium, 45/90 deg) | 1 |
| 7 | Transmission cooler line – (long, 45/90 deg) | 1 |



WARNINGS:

- Use of this product may void or nullify the vehicle’s factory warranty.
- User assumes sole responsibility for the safe & proper use of the vehicle at all times.
- The purchaser and end user releases, indemnifies, discharges, and holds harmless Fleece Performance Engineering, Inc. from any and all claims, damages, causes of action, injuries, or expenses resulting from or relating to the use or installation of this product that is in violation of the terms and conditions on this page, the product disclaimer, and/or the product installation instructions. Fleece Performance Engineering, Inc. will not be liable for any direct, indirect, consequential, exemplary, punitive, statutory, or incidental damages or fines cause by the use or installation of this product.

INSTALLATION INSTRUCTIONS

NOTE: Allow the coolant system and transmission to cool. Relieve the coolant pressure from the coolant system by removing the coolant cap.

FRONT GRILL AND BUMPER REMOVAL

Remove the engine bay plastic cover panel by removing the plastic expansion fasteners that retain it to the front grill and body.



Remove the front grill retention bolts located along the top of the grill.

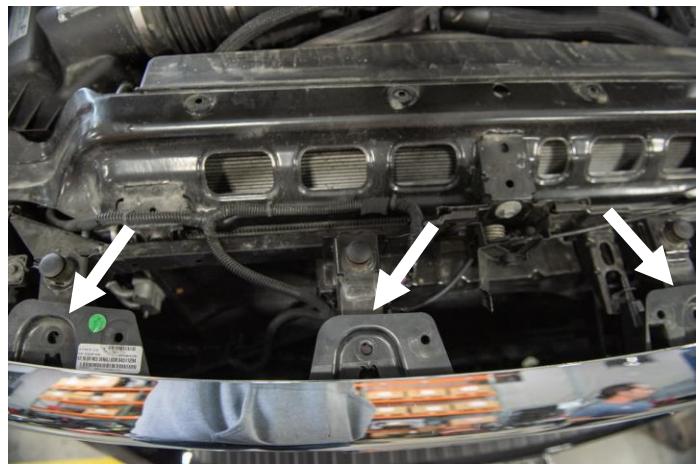

Remove the passenger side air deflector located between the core support and radiator.

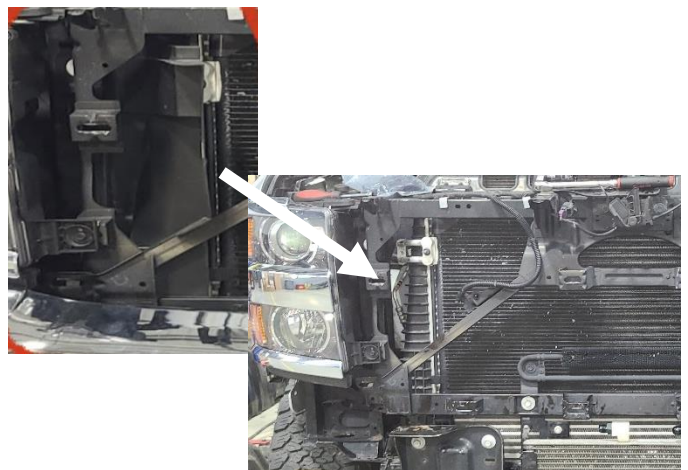

INSTALLATION INSTRUCTIONS

Using a long pry bar, release the lower retaining clips for the front grill.



ENGINE BAY

To allow for removal of the existing OE lines and installation of the new lines:

Disconnect sensors and remove the engine air intake

Remove the coolant reservoir support brace

Remove the passenger side CAC pipe



INSTALLATION INSTRUCTIONS

FENDER LINER

To allow for removal of the existing OE lines and installation of the new lines remove the passenger side fender liner.



INSTALLATION INSTRUCTIONS

OEM TRANSMISSION LINE REMOVAL

Remove the clips that retain the transmission lines to the transmission, radiator, and transmission cooler with a small pic or screwdriver. Disconnect the OE lines at each location and remove the OE line assemblies from the truck.

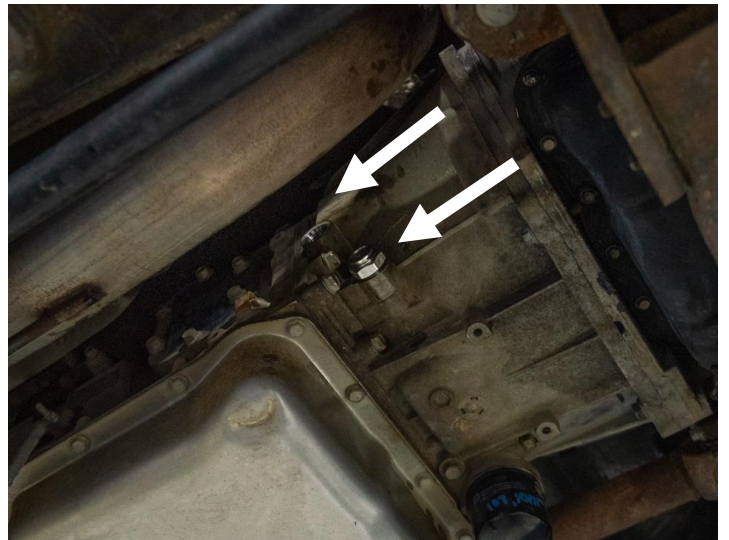
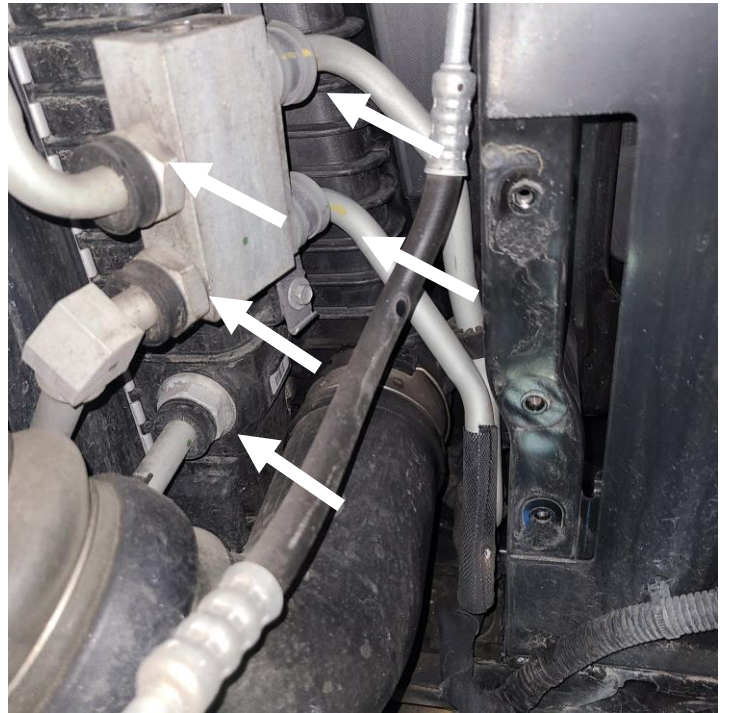

INSTALLATION INSTRUCTIONS

With the OE transmission lines removed from the truck, use a 1 1/8" back up wrench and 1 1/4" socket or wrench to remove the factory fittings from each side of the transmission cooler.

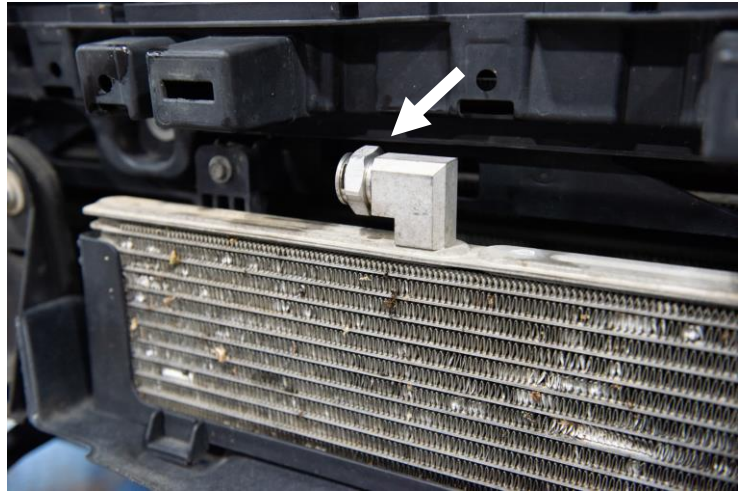

NEW FITTING INSTALLATION

Use a backup wrench when removing the factory fittings from the transmission cooler and when installing the new fittings included with the kit.



Install two of the 7/8"-14 O-ring to -10AN fittings into the left and right side ports of the oil cooler.

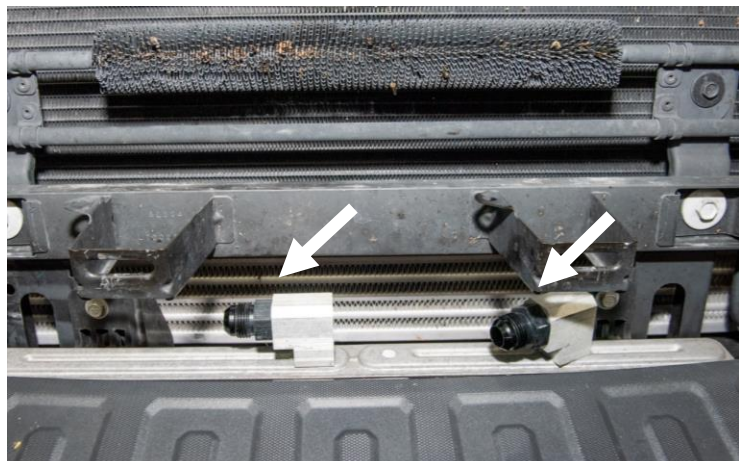

INSTALLATION INSTRUCTIONS

Assemble the large flat washers onto two of the 7/8"-14 O-ring to -10AN fittings.

- A. **Remove** the O-ring from the fitting.
- B. Place the large flat washer on the side where you removed the O-ring and **replace** the O-ring onto the fitting with the washer below it.
- C. Install into the radiator, removing and replacing one fitting at a time.

IMPORTANT NOTE: Install and remove ONE FITTING AT A TIME on the radiator, removing both fittings at the same time may result in the internal cooler coming loose on the inside of the tank.

Remove the two OE fittings from the transmission using a 1 1/4" socket or wrench.

Install two of the 7/8"-14 O-ring to -10AN fittings into the "To Cooler" and "From Cooler" ports on the transmission.

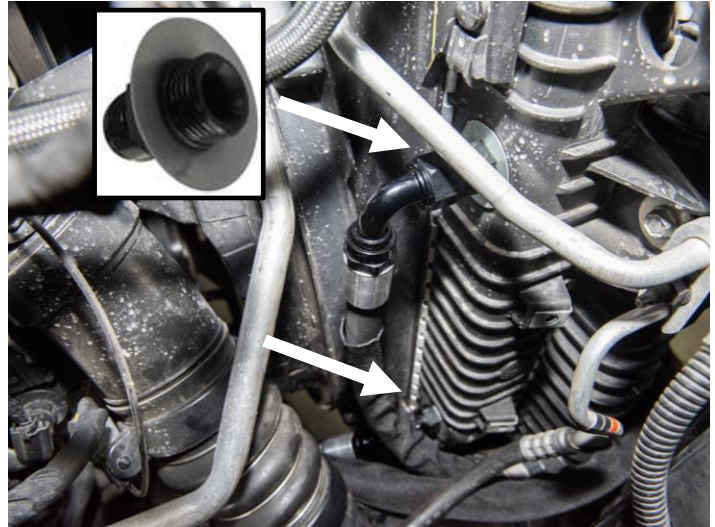

INSTALLATION INSTRUCTIONS

ROUTING DIAGRAM

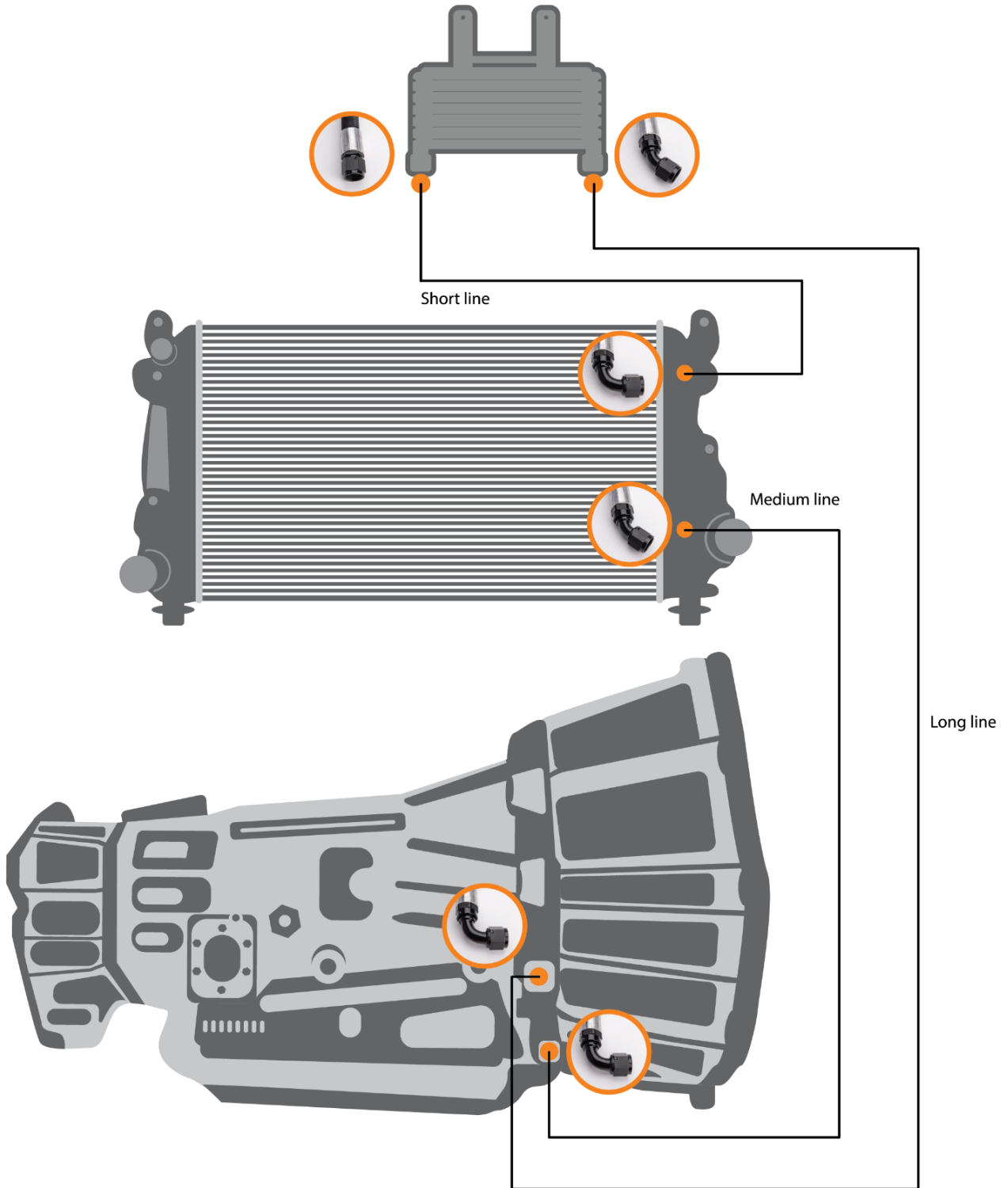

INSTALLATION INSTRUCTIONS

RECOMMENDED LINE ROUTINGS

Route the long and medium length lines to the transmission closely alongside the transmission bell housing, and below the engine oil pan along the passenger side. Use a double hose clamp and zip ties to retain the hose assemblies.



Route the long and medium length lines over the main chassis members and suspension anti-roll bar.

Route the lines uniformly along the passenger side of the chassis, just inside the frame rails by approximately 6".

The medium length hose is routed from the transmission "TO COOLER" to the bottom-side radiator fitting. The 45 degree fitting is utilized on the radiator side, aligned slightly downward and toward the center of the chassis.

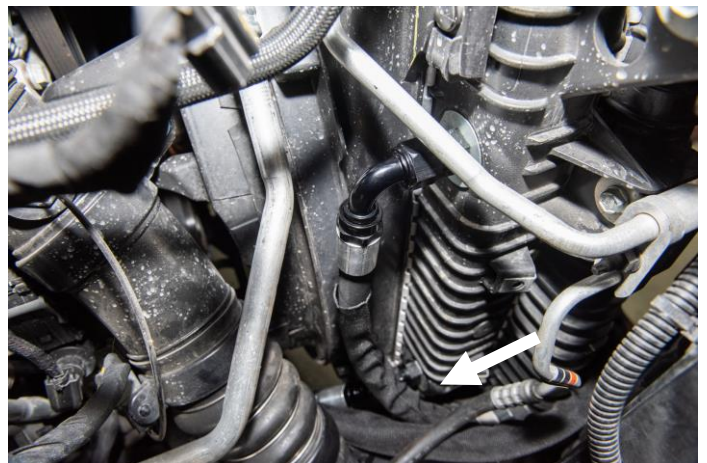

INSTALLATION INSTRUCTIONS

RECOMMENDED LINE ROUTINGS

The longest line should be routed to the right-hand side (driver side) of the transmission cooler. Route the lines behind the grille support bracket and around the passenger side of the radiator. Both the left and right side lines will route together around the side of the radiator.



The shortest line is routed from the left side (passenger side) of transmission cooler to the top-side radiator fitting.



Use one of the zip ties provided in the kit to secure the hoses together and to the cross-member.

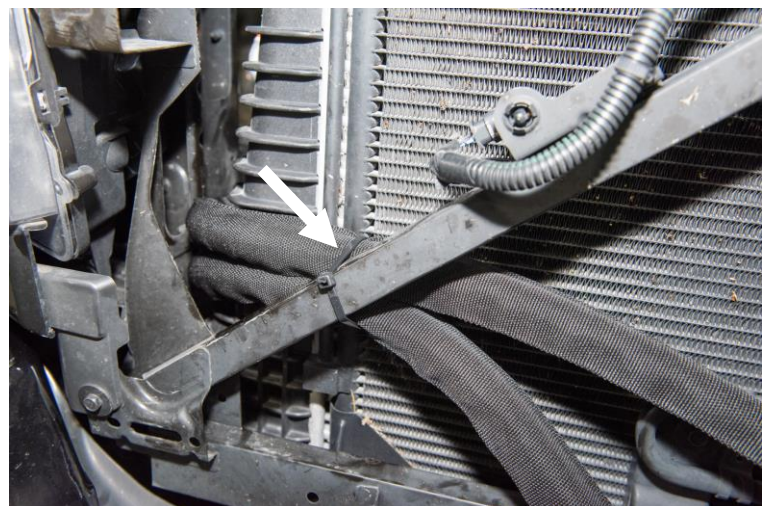

INSTALLATION INSTRUCTIONS

RECOMMENDED LINE ROUTINGS

The shortest line is run from the left side of the transmission cooler, around the passenger side of the radiator, and up to the top side fitting.



The medium length line is run from the bottom radiator fitting to the "FROM COOLER" port on the transmission. The 45 degree fitting will be pointed slightly inward toward the center of the vehicle and downward.

