



# INSTALLATION INSTRUCTIONS

**SUBJECT: DODGE CUMMINS TRANSMISSION COOLER LINE KIT**

FPE-2018-07  
October, 2018  
Page 1 of 7

**FITMENT:** 2010–2012 Dodge Cummins with 68 RFE Automatic Transmission and Transmission Cooler

**KIT P/N:** FPE-TL-CUMM-1012

**ESTIMATED INSTALLATION TIME:** 1.5 - 2 Hours

**TOOLS REQUIRED:** 1" open end wrench, 10 mm socket, 13 mm socket, 14 mm socket, small flathead screw driver

**KIT CONTENTS:**

Item	Description	Qty
1	-8AN to ¼"-16 fittings	4
2	11/16" P-clamp	1
3	1 3/4" P-clamp	1
4	Double Hose Zip Ties	4
5	Transmission cooler line (supply side)	1
6	Transmission cooler line (return side)	1

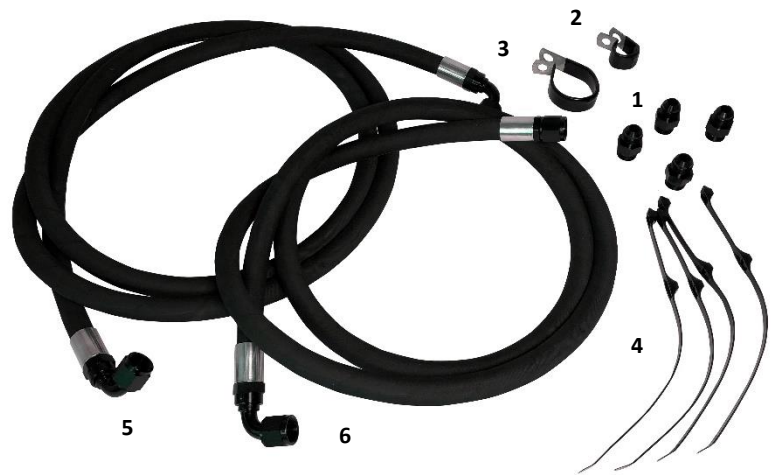

**WARNINGS:**

- Use of this product may void or nullify the vehicle’s factory warranty.
- User assumes sole responsibility for the safe & proper use of the vehicle at all times.
- The purchaser and end user releases, indemnifies, discharges, and holds harmless Fleece Performance Engineering, Inc. from any and all claims, damages, causes of action, injuries, or expenses resulting from or relating to the use or installation of this product that is in violation of the terms and conditions on this page, the product disclaimer, and/or the product installation instructions. Fleece Performance Engineering, Inc. will not be liable for any direct, indirect, consequential, exemplary, punitive, statutory, or incidental damages or fines cause by the use or installation of this product.

# INSTALLATION INSTRUCTIONS

FPE-2018-07  
October, 2018  
Page 2 of 7

## PROCEDURE:

STEP 1: Remove four (4) bolts that retain the front grill to provide access to the transmission cooler using a 10 mm socket.



STEP 2: Remove the bolt on the head above the fuel filter housing that retains the OEM cooling lines using a 13 mm socket.

STEP 3: Remove the bolt on the bellhousing that retains the OEM cooling lines using a 14 mm socket.



# INSTALLATION INSTRUCTIONS

FPE-2018-07  
October, 2018  
Page 3 of 7

STEP 4: Remove the c-clip retainers at the heat exchanger (2 locations), and release the retaining caps to free the line from the port.



STEP 5: Remove the c-clip retainers at the transmission (2 locations), and release the retaining caps to free the lines from the port.

*NOTE: Fluid inside the lines will drain, be prepared to catch the fluid with a bucket or pail.*

STEP 6: With both ends of the OEM cooling lines disconnected, manipulate the lines out from the truck. Removal from the bottom is easiest.



# INSTALLATION INSTRUCTIONS

FPE-2018-07  
October, 2018  
Page 4 of 7

**STEP 7:** Using a 1" wrench, remove the factory fittings from the transmission cooler and replace them with the -8AN to 3/4"-16 fittings (item 1) in two locations.

**NOTE:** Retain the factory fitting on the transmission cooler with a wrench to prevent any torque into the transmission cooler housing when tightening the cooler line fitting.



**STEP 8:** Install the Fleece Performance cooler lines (items 5, 6) along the same path as the factory lines were routed, taking care to ensure the lines are clear of any rotating and sharp objects prior to securing them. Loosely thread the fittings for each line at each connection point.



# INSTALLATION INSTRUCTIONS

FPE-2018-07  
October, 2018  
Page 5 of 7

STEP 7: Using a 1" wrench, remove the factory fittings from the transmission and replace them with the -8AN to 3/4"-16 fittings (item 1) in two locations.

STEP 8: Loosely connect the fittings for the transmission cooler lines. Do not fully tighten.



STEP 9: Using four double-hose zip ties (item 4), space them evenly along the length of the cooler lines. Tighten the ties to retain the hoses together.

STEP 10: Retain both cooler lines to the transmission bell housing using the 1 3/4" P-clamp (item 3).



STEP 11: Retain the upper cooler lines to the grill using the 11/16" P-clamp (item 2).



STEP 11: With the cooler lines routed and retained, tighten each of the four cooler line fittings to 270-350 in-lbs. Use a backup wrench on the fitting installed in the housings of the transmission cooler and transmission to prevent over torqueing.

STEP 12: Re-install the grill.

STEP 13: Start engine and verify the installation is leak-free. Check and confirm transmission fluid level is within specification, adjust as necessary with the OEM's approved fluid.

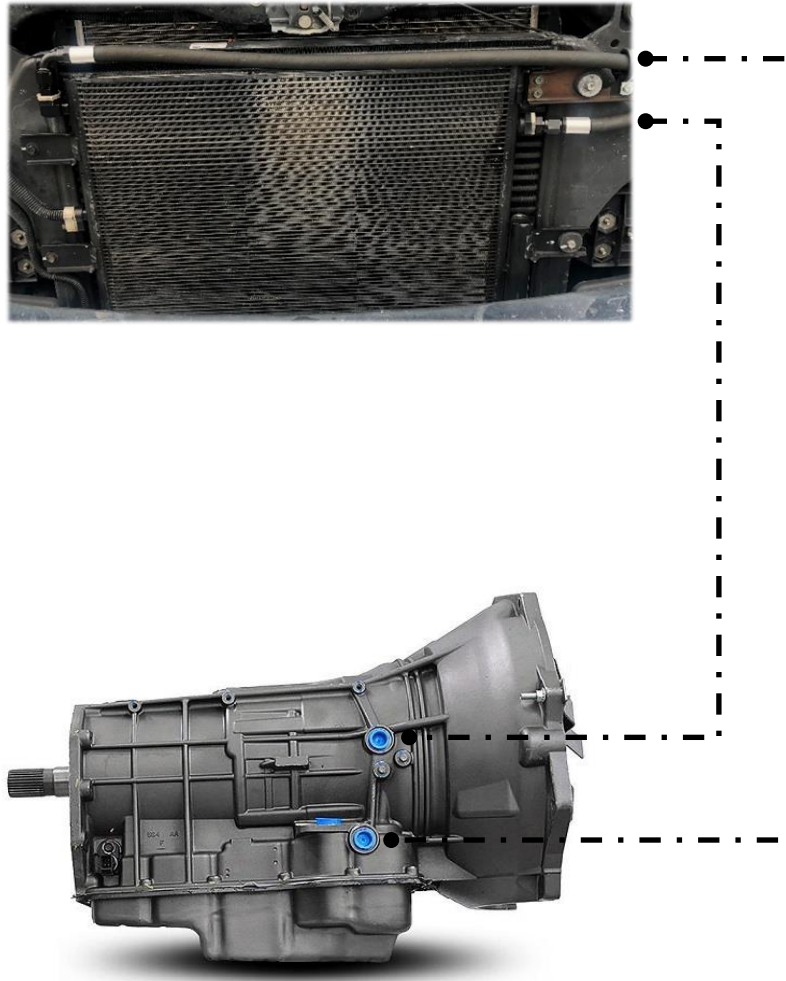

Visit <https://fleeceperformance.com/resources> for the latest instructions and videos.

For Technical Assistance contact Fleece Performance Engineering at 855-839-5040.